



TBM 700
Version C

PILOT'S INFORMATION MANUAL

CAUTION

THIS INFORMATION MANUAL IS A NON-OFFICIAL COPY OF THE PILOT'S OPERATING HANDBOOK AND MAY BE USED FOR GENERAL INFORMATION PURPOSES ONLY.

IT IS NOT KEPT CURRENT AND THEREFORE CANNOT BE USED AS A SUBSTITUTE FOR AIRWORTHINESS AUTHORITIES APPROVED MANUAL WHICH IS THE ONLY ONE INTENDED FOR OPERATION OF THE AIRPLANE.

The content of this document is the property of SOCATA SAS. It is supplied in confidence and commercial security of its contents must be maintained. It must not be used for any purpose other than that for which it is supplied, nor may information contained in it be disclosed to unauthorized persons. It must not be reproduced nor transmitted in any form in whole or in part without permission in writing from the owners of the Copyright.

Information in this document is subject to change without notice.

© 2002 thru 2012, 2014 – SOCATA SAS – All rights reserved

For any information concerning this document, please contact :

SOCATA SAS

CUSTOMER SUPPORT
65921 TARDES CEDEX 9
FRANCE

TELEPHONE : 33 (0)5 62.41.73.00

TELEFAX : 33 (0)5 62.41.76.54

SOCATA MODIFICATIONS - INDEX**NOTE :**

The standardized name for SOCATA modifications is :

MOD70-XXX-XX

MOD70 No.	SUBJECT	CLASSIF.
021-32	New A14 landing gear control panel	Major
124-71	Engine drains	minor
138-53	ELT housing	minor
139-00	TBM 700 takeoff max. weight increase	Major
140-00	Evolutions from TBM 700B to TBM 700C1 : MTOW 6579 lbs (2984 kg)	Major
142-21	Air cycle system (ACS)	Major
143-21	Vapor cycle cooling system (VCCS)	Major
144-33	Cabin lighting telebreaker	minor
145-53	Aft baggage compartment (non-pressurized)	Major
146-00	Clamp type modification on airspeed indicating system and cabin pressurization regulation system	minor
148-25	Crash-proof seat backward displacement (TBM 700C2)	Major
0155-21	Vapor cycle cooling system (VCCS) - Low pressure evaporator - TBM700C equipped with MOD70-143-21	minor
0156-32	AIR SYSTEMS control panel and landing gear indicating P/N A14 LGCP 94-11 Amdt D	minor
0157-21	Evaporator air inlet protection - TBM700C not equipped with MOD70-155-21	minor

MOD70 No.	SUBJECT	CLASSIF.
0161-27	Aileron control emergency stop	minor
0162-21	Air cycle system (ACS) - TBM700C equipped with MOD70-142-21	minor
0163-77	Torque transducer static port tube	minor
0166-53	Change of glass fiber fabric type on TBM 700 composite floors	minor
0168-57	Modification of TBM 700 internal flap carriage pin definition (external flap carriages are processed by amendment)	minor
0170-23	Separation of audio circuit low points (GMA 340) - TBM 700 equipped with option OPT70 23023	minor
0172-57	Replacement on flaps of SHUR LOCK nuts by machined bushings	minor
0173-28	New fuel gauging probes	minor
0175-23	BOSE headset wiring (Front and rear)	minor
0177-57	Lower attachment fittings of external flap tracks	minor
0183-56	Side windows "generation 2006"	minor
0184-56	Cabin windows "generation 2006"	minor
0185-21	Moving of ECS probe to the bulkhead top - TBM 700C S/N 205, 240, 245 to 268, 270 to 286, 288	minor
0186-57	Inserts hot-fitted on flap ribs	minor
0190-32	Reinforcement of main landing gear legs	Major
0191-71	Engine drainage breather pipe modification - TBM 700A, B, C equipped with MOD70-124-71 (engine drainage) and TBM 700N (850)	minor
0194-25	Linings Generation 2005-3	minor

MOD70 No.	SUBJECT	CLASSIF.
0195-56	Rear cabin window (same as front cabine window)	minor
0201-32	Landing gear actuating cylinder modification	minor
0205-55	Replacement of fin expansion pins	minor
0209-57	Reinforcement of trailing edge omega at rib 7	minor
0213-27	Pitch trim union connector at rear pressure bulkhead	minor
0217-24	Battery firewall screen	minor
0256-76	Condition lever locking in HI-IDLE position	minor
0402-28	Fuel sequencer evolution	minor

INTENTIONALLY LEFT BLANK

TABLE OF CONTENTS

	SECTION
GENERAL	1
LIMITATIONS	2
EMERGENCY PROCEDURES	3
NORMAL PROCEDURES	4
PERFORMANCE	5
WEIGHT AND BALANCE	6
DESCRIPTION	7
AIRPLANE HANDLING, SERVICING AND MAINTENANCE	8
SUPPLEMENTS	9

SECTION 1**GENERAL****TABLE OF CONTENTS**

	Page
1.1 GENERAL	1.1.1
1.2 THREE VIEW DRAWING	1.2.1
1.3 DESCRIPTIVE DATA	1.3.1
ENGINE	1.3.1
PROPELLER	1.3.1
FUEL	1.3.2
ENGINE OIL	1.3.3
MAXIMUM CERTIFICATED WEIGHTS	1.3.3
STANDARD AIRPLANE WEIGHTS	1.3.3
CABIN AND ENTRY DIMENSIONS	1.3.4
SPECIFIC LOADINGS	1.3.4
1.4 ABBREVIATIONS AND TERMINOLOGY	1.4.1
METEOROLOGICAL TERMINOLOGY	1.4.1
GENERAL AIRSPEED TERMINOLOGY AND SYMBOLS	1.4.1
POWER TERMINOLOGY	1.4.3
AIRPLANE PERFORMANCE AND FLIGHT PLANNING TERMINOLOGY	1.4.4
WEIGHT AND BALANCE TERMINOLOGY	1.4.4
GENERAL ABBREVIATIONS	1.4.6
RADIO - NAVIGATION ABBREVIATIONS	1.4.9
EFIS ABBREVIATIONS	1.4.10
1.5 CONVERSION FACTORS	1.5.1
1.6 PRESSURE AND STANDARD ATMOSPHERE	1.6.1
STANDARD ATMOSPHERE	1.6.1
PRESSURE CONVERSION TABLE	1.6.2

INTENTIONALLY LEFT BLANK

1.1 - GENERAL

This Handbook contains 9 Sections, and includes the material required by FAR Part 23 to be furnished to the pilot for operation of the TBM 700 airplane. It also contains supplemental data supplied by the manufacturer.

Section 1 provides basic data and information of general interest. It also contains definitions or explanations of abbreviations and terminology commonly used.

The general for complex optional systems are given in Section 9, "Supplements" of the Pilot's Operating Handbook.

INTENTIONALLY LEFT BLANK

1.2 - THREE VIEW DRAWING

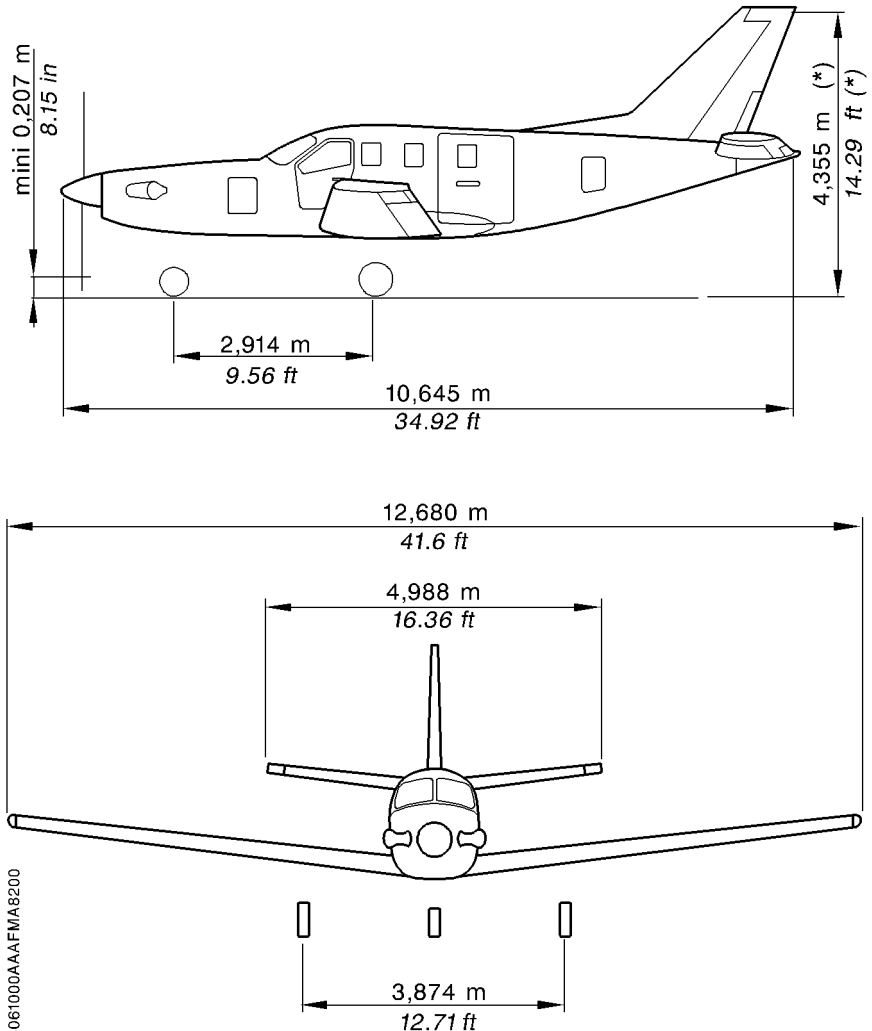

- * Avion en ligne de vol avec amortisseur AV détendu
- * Airplane on line of flight with extended FWD shock-absorber

Figure 1.2.1 (1/2) - THREE VIEW DRAWING

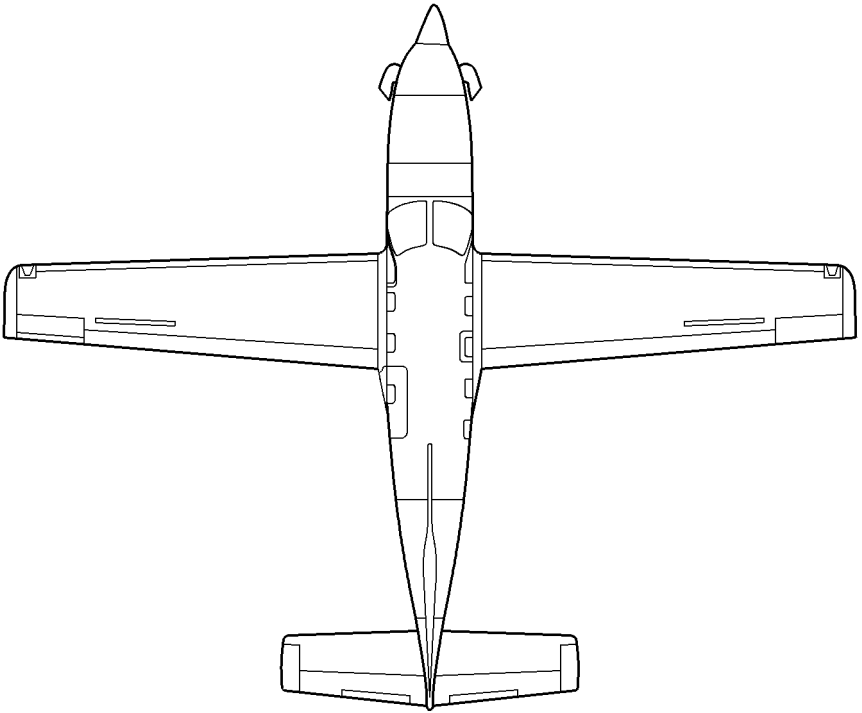

14-061000AAA AFMA8101

Figure 1.2.1 (2/2) - THREE VIEW DRAWING

1.3 - DESCRIPTIVE DATA

ENGINE

Number of engines : 1

Engine manufacturer : PRATT & WHITNEY CANADA

Engine model number : PT6A - 64

Engine type : Free turbine, reverse flow and 2 turbine sections

Compressor type : 4 axial stages
1 centrifugal stage

Combustion chamber type : Annular

Turbine type : 1 gas generator turbine stage
2 power turbines stages

■ Horsepower rating and propeller speed : 700 SHP at 2000 RPM

PROPELLER

Number of propellers : 1

Propeller manufacturer : HARTZELL

Propeller model number : HC-E4N-3 / E9083S (K)

Number of blades : 4

Propeller diameter :
Minimum : 90 inches (2.286 m)
Maximum : 91 inches (2.311 m)

Propeller type : Adjustable constant speed, with feathering and hydraulic control reverse

Propeller blade setting at 30 inches station

Low pitch : 21°
Feathering : 86°
Maximum reverse : - 11°

Propeller governor : 8210.007 WOODWARD

FUEL

Total capacity : 290.6 us gal (1100 Litres)
 Total capacity each tank : 145.3 us gal (550 Litres)
 Total usable : 281.6 us gal (1066 Litres)

CAUTION

THE USED FUEL MUST CONTAIN AN ANTI-ICE ADDITIVE, IN ACCORDANCE WITH SPECIFICATION MIL-I-27686 or MIL-I-85470. ADDITIVE CONCENTRATIONS (EGME or DIEGME) SHALL BE COMPRISED BETWEEN A MINIMUM OF 0.06 % AND A MAXIMUM OF 0.15 % BY VOLUME. REFER TO SECTION 8 "HANDLING, SERVICING AND MAINTENANCE" FOR ADDITIONAL INFORMATION.

CAUTION

THE USE OF AVIATION GASOLINE (AVGAS) MUST BE RESTRICTED TO EMERGENCY PURPOSES ONLY. AVGAS SHALL NOT BE USED FOR MORE THAN 150 CUMULATIVE HOURS DURING ANY PERIOD BETWEEN ENGINE OVERHAUL PERIODS

NOTE :

Use of AVGAS to be recorded in engine module logbook

US Specification (US)	French Specification (FR)	English Specification (UK)	NATO Code
ASTM-D1655 JET A ASTM-D1655 JET A1 ASTM-D1655 JET B	AIR 3405C Grade F35	DERD 2494 Issue 9	F35 without additive
MIL-DTL-5624 Grade JP-4	AIR 3407B	DERD 2454 Issue 4 Amdt 1	F40 with additive
MIL-DTL-5624 Grade JP-5	AIR 3404C Grade F44	DERD 2452 Issue 2 Amdt 1	F44 with additive when utilization
MIL-DTL-83133 Grade JP-8	AIR 3405C Grade F34	DERD 2453 Issue 4 Amdt 1	F34 with additive S748
	AIR 3404C Grade F43	DERD 2498 Issue 7	F43 without additive

Figure 1.3.1 - RECOMMENDED FUEL TYPES
 (Reference : Service Bulletin P & W C. No. 14004)

ENGINE OIL

System total capacity :

12.7 Quarts (12 Litres) (oil cooler included)

Usable capacity :

6 Quarts (5.7 Litres)

- Maximum consumption : 0.14 qt / hr (0.13 l / hr)
[0.3 lb/hr (0.136 kg/h)]

CAUTION

DO NOT MIX DIFFERENT BRANDS OR TYPES

Nominal Viscosity	US Specification (US)	French Specification (FR)	English Specification (UK)	NATO Code
Type 5cSt	MIL-L-23699C Amdt1	MIL-L-23699C Amdt1	DERD 2499 Issue 1	O.156

Figure 1.3.2 – RECOMMENDED ENGINE OIL TYPES
(Reference : Service Bulletin P & W C. No. 14001)

MAXIMUM CERTIFICATED WEIGHTS

(Refer to Supplement 41 for TBM 700C2 airplane)

Ramp : 6614 lbs (3000 kg)

Takeoff : 6579 lbs (2984 kg)

Landing : 6250 lbs (2835 kg)

Baggage weight (refer to Section 6 for cargo loading instructions) :

In rear part of pressurized cabin : 220 lbs (100 kg)

In aft compartment : 77 lbs (35 kg)

STANDARD AIRPLANE WEIGHTS

Standard empty weight : 4167 lbs (1890 kg)

With "pilot" door : 4211 lbs (1910 kg)

Maximum useful load : 2447 lbs (1110 kg)

With "pilot" door : 2403 lbs (1090 kg)

CABIN AND ENTRY DIMENSIONS

Maximum cabin width : 3' 11.64" (1.21 m)

Maximum cabin length : 13' 3.45" (4.05 m)

Maximum cabin height : 4' (1.22 m)

Number of cabin entries : 1 (standard) + 1 "pilot" door (if installed)

Entry width (standard) : 3' 6.52" (1.08 m)

Entry height (standard) : 3' 10.85" (1.19 m)

"Pilot" entry mean width : 2' 3.6" (0.70 m)

"Pilot" entry mean height : 3' 2.16" (0.97 m)

SPECIFIC LOADINGS

- (Refer to Supplement 41 for TBM 700C2 airplane)

Wing loading : 34 lbs / sq.ft (165.8 kg / m²)

Power loading : 9.4 lbs / SHP (4.26 kg / SHP)

1.4 - ABBREVIATIONS AND TERMINOLOGY

METEOROLOGICAL TERMINOLOGY

- ISA** : *International standard atmosphere*
- OAT** : *Outside air temperature* is the free air static temperature. It is expressed in either degrees Celsius or degrees Fahrenheit.
- SAT** : *Static air temperature*
- IOAT** : *Indicated outside air temperature*
- QFE** : Atmospheric pressure at the airport reference point.
- QNH** : QFE value corrected according to the airport altitude.

NOTE :

On the ground, the altimeter will indicate "zero" if it is set to QFE ; it will indicate airport altitude if it is set to QNH.

Standard Temperature :

Is 15°C (59°F) at sea level pressure altitude and decreases by 2°C (3.6°F) for each 1000 ft of altitude.

Pressure altitude :

Is the altitude read from an altimeter when the altimeter's barometric scale has been set to 29.92 inches of mercury (1013.2 hPa).

GENERAL AIRSPEED TERMINOLOGY AND SYMBOLS

- KCAS** : *Knots Calibrated Airspeed* is the indicated airspeed expressed in knots corrected for position and instrument error. Knots calibrated airspeed is equal to KTAS in standard atmosphere at sea level.
- KIAS** : *Knots Indicated Airspeed* is the speed shown on the airspeed indicator and expressed in knots.
- KTAS** : *Knots True Airspeed* is the airspeed expressed in knots relative to undisturbed air which is KCAS corrected for altitude and temperature.

- V_A : **Maneuvering Speed** is the maximum speed at which full or abrupt control movements may be used.
- V_{FE} : **Maximum Flap Extended Speed** is the highest speed permissible with wing flaps in a prescribed extended position.
- V_{LE} : **Maximum Landing Gear Extended Speed** is the maximum speed at which an airplane can be safely flown with the landing gear extended.
- V_{LO} : **Maximum Landing Gear Operating Speed** is the maximum speed at which the landing gear can be safely extended or retracted.
- V_{MO} : **Maximum Operating Speed** is the speed limit that may not be deliberately exceeded in normal flight operations.
- V_R : **Rotation Speed** is the speed at which rotation is initiated during takeoff to achieve takeoff safety speed at screen height.
- V_{SO} : **Stalling Speed or the minimum steady flight speed** at which the airplane is controllable in the landing configuration.
- V_{S1} : **Stalling Speed or the minimum steady flight speed** obtained in a specific configuration.
- V_x : **Best Angle of Climb Speed** is the airspeed which delivers the greatest gain of altitude in the shortest possible horizontal distance.
- V_y : **Best Rate of Climb Speed** is the airspeed which delivers the greatest gain in altitude in the shortest possible time.

POWER TERMINOLOGY**Recovery altitude :**

Maximum altitude at which it is possible, in standard temperature, to maintain a specified power.

Overheated start :

Engine start or attempt to start which causes the interturbine temperature to be higher than the maximum value permissible during start .

Flame out : Involuntary loss of the combustion chamber flame during operation.

GPU : *Ground power unit.*

Feathering : Action which reduces the drag of a failed engine through propeller feathering.

Maximum Cruise Power :

Power developed at the couple limit, interturbines temperature limit or gas generator RPM limit without time limitations, corresponding to cruise conditions.

Ng : Gas generator RPM.

Np : Propeller rotation speed.

Reverse : Drag produced when the propeller blade setting is negative.

RPM : Revolutions per minute is engine speed.

SHP : Standard Horsepower is the power developed by the engine.

TRQ : *Torque.*

AIRPLANE PERFORMANCE AND FLIGHT PLANNING TERMINOLOGY

Climb gradient :

Is the ratio of the change in height during a portion of climb, to the horizontal distance traversed in the same time interval.

Demonstrated crosswind velocity :

Is the velocity of the crosswind component for which adequate control of the airplane during takeoff and landing was actually demonstrated during certification tests. The value shown is not considered to be limiting.

g : Is acceleration due to gravity.

Usable fuel : Total fuel which can be effectively consumed by the engine.

WEIGHT AND BALANCE TERMINOLOGY

Reference datum :

Datum perpendicular to the longitudinal airplane centerline from which all distances are measured for balance purpose.

Arm : Is the distance from the reference datum to the center of gravity (C.G.) of an item.

Moment : Is the product of the weight of an item multiplied by its arm.

Center of gravity (C.G.) :

Airplane balance point. Its distance from the reference datum is found by dividing the total moment by the total weight of the airplane.

C.G. limits : *Center of Gravity Limits* are the extreme center of gravity locations within which the airplane must be operated at a given weight.

Standard empty weight :

Weight of a standard airplane including unusable fuel and full operating fluids (oil and hydraulic fluids).

Basic empty weight :

Standard empty weight plus optional equipment.

Useful load : Is the difference between maximum ramp weight and the basic empty weight.

Maximum ramp weight :

Is the maximum weight approved for ground maneuver. (It includes the weight of start, taxi and run up fuel).

Maximum takeoff weight :

Is the maximum weight approved at the beginning of the takeoff run.

Maximum landing weight :

Is the maximum weight approved for landing touchdown.

GENERAL ABBREVIATIONS

A	: Ampere or Amber
ADC	: Air Data Computer
AIL TRIM	: Aileron trim
ALT. SEL.	: Altitude selector
ALTI	: Altimeter
AMP.	: Ampere
AP	: Autopilot
AUTO SEL	: Automatic selector
AUX BP	: Auxiliary boost pump
BAT	: Battery
BAT OVHT	: Battery overheat
BRT	: Brightness
CAB PRESS	: Cabin pressure
°C	: Celsius degree
CONT.	: Control
DIEGME	: Diethylene glycol monomethyl ether
DIM	: Dimmer
DISC	: Disconnect
DN	: Down
ECS	: Environmental control system
EGME	: Ethylene glycol monomethyl ether
EMER	: Emergency
ENCOD. ALTI	: Encoding altimeter
ESS. BUS TIE	: Essential BUS tie
ETM	: Engine Trend Monitoring
EXT. LIGHTS	: Exterior lightings
°F	: Fahrenheit degree
FCU	: Fuel control unit
FIRE EXTING	: Fire extinguisher
FL	: Flight level
ft	: Feet
ft/min	: Feet per minute
G	: Green
HI	: High
HP	: High pressure
hPa	: Hectopascal
hr	: Hour
HTR	: Heater
IGNIT	: Ignition
in	: Inch

INERT SEP	: Inertial separator
INDIC	: Indicator
in.Hg	: Inch of mercury
INT. LIGHTS	: Interior lightings
INSTR.	: Instrument
IRCR	: Intermediate range cruise
ITT	: Interturbine temperature
kg	: Kilogram
kt	: Knot (1 nautical mile/hr - 1852 m/hr)
kW	: Kilowatt
l	: Litre
L	: Left
l/h	: Litre / hour
lb or lbs	: Pound(s)
L / D	: Lift-to-drag
LDG	: Landing
LDG GR	: Landing gear
LRCR	: Long Range Cruise
LO	: Low
LP	: Low pressure
LRN	: Long range navigation
LTS TEST	: Lightings test
m	: Metre
m.a.c.	: Mean aerodynamic chord
MAIN GEN	: Main generation
MAN	: Manual
MAN OVRD	: Manual override
MAX RPM	: Maximum revolutions per minute
MIN	: Minimum
min	: Minute
MLW	: Maximum landing weight
mm	: Millimetre
MRW	: Maximum ramp weight
MTOW	: Maximum Takeoff Weight
MXCR	: Maximum cruise
MZFW	: Max. Zero Fuel Weight
NM	: Nautical mile
NOCR	: Normal cruise (recommended)
NORM	: Normal
PHF	: Plan Horizontal Fixe (Horizontal stabilizer)

qt	: Quart (1/4 us gal)
QTY	: Quantity
R	: Red or Right
RUD	: Rudder
s or sec	: Second
SEL	: Selector
SIG	: Signalization
SL	: Sea level
S/N	: Serial number
SPKR	: Speaker
ST - BY	: Stand-by
STALL HTR	: Stall heater
Std	: Standard
T°	: Temperature
TEMP	: Temperature
TO	: Takeoff
TURN COORD	: Turn coordinator
us gal	: Gallon U.S
V	: Volt or Voltage
VACUUM LO	: Vacuum low
WARN	: Warning
W / S	: Windshield
WSR	: Weather surveillance radar
XPDR	: Transponder

RADIO - NAVIGATION ABBREVIATIONS

ADF	: Automatic Direction Finder System
ADI	: Attitude Director Indicator
ATC	: Transponder
CDI	: Course Deviation Indicator
COM	: Communications Transceivers
DME	: Distance Measuring Equipment
EGPWS	: Enhanced Ground Proximity Warning System
ELT	: Emergency Locator Transmitter
GPS	: Ground Positioning System
HF	: High Frequency
HSI	: Horizontal Situation Indicator
IFR	: Instrument Flight Rules
ILS	: Instrument Landing System
IMC	: Instrument Meteorological Conditions
MFD	: Multi-function Display
MKR	: Marker Radio Beacon
NAV	: Navigation Indicators or Receivers
RMI	: Radio Magnetic Indicator
TAS	: Traffic Advisory System
TAWS	: Terrain Awareness Warning System
VFR	: Visual Flight Rules
VHF	: Very High Frequency
VMC	: Visual Meteorological Conditions
VOR	: VHF Omnidirectional Range
VOR / LOC	: VHF Omnidirectional Range Localizer

EFIS ABBREVIATIONS

ATTITUDE FAIL: Attitude failure

CMPST : Composite
(EFIS composite mode)

CP : Control Panel

CRS : Course

DU : Display Unit

FD : Flight director

EADI : Electronic Attitude Deviation Indicator

EFIS : Electronic Flight Instrument System

EHSI : Electronic Horizontal Situation Indicator

ERMI : Electronic Radio Magnetic Indicator

HDG : Heading

RCP : Radar Control Panel

REF : Reference

SG : Symbol Generator

TST : Test

1.5 - CONVERSION FACTORS

IMPERIAL AND U.S UNITS TO METRIC UNITS			METRIC UNITS TO IMPERIAL AND U.S UNITS		
MULTIPLY	BY	TO OBTAIN	MULTIPLY	BY	TO OBTAIN
FEET	0.3048	METRE	METRE	3.2808	FEET
INCH	25.4	mm	mm	0.03937	INCH
Imp.Gal	4.546	Litre	Litre	0.220	Imp.Gal
us gal	3.785	Litre	Litre	0.264	us gal
lb	0.45359	kg	kg	2.2046	lb

Figure 1.5.1 - IMPERIAL AND U.S UNITS TO METRIC UNITS

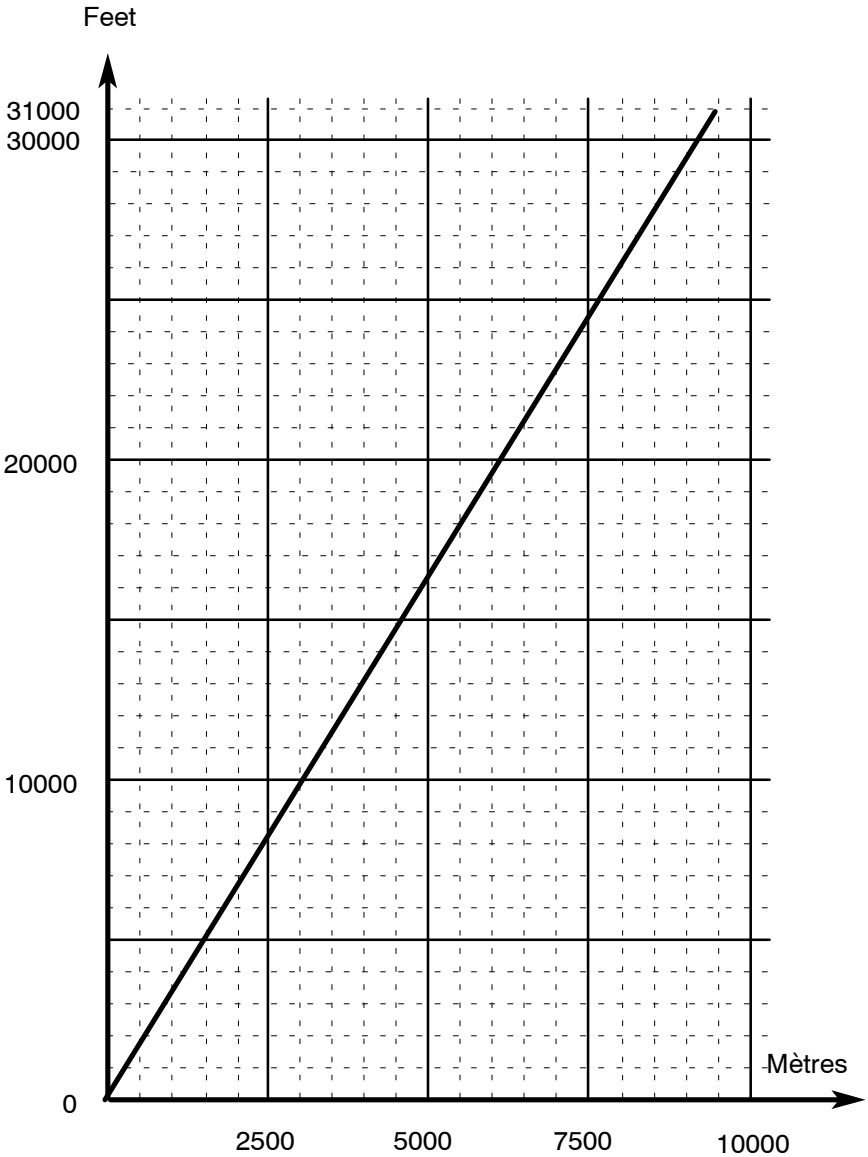

Figure 1.5.2 - FEET VERSUS METRES

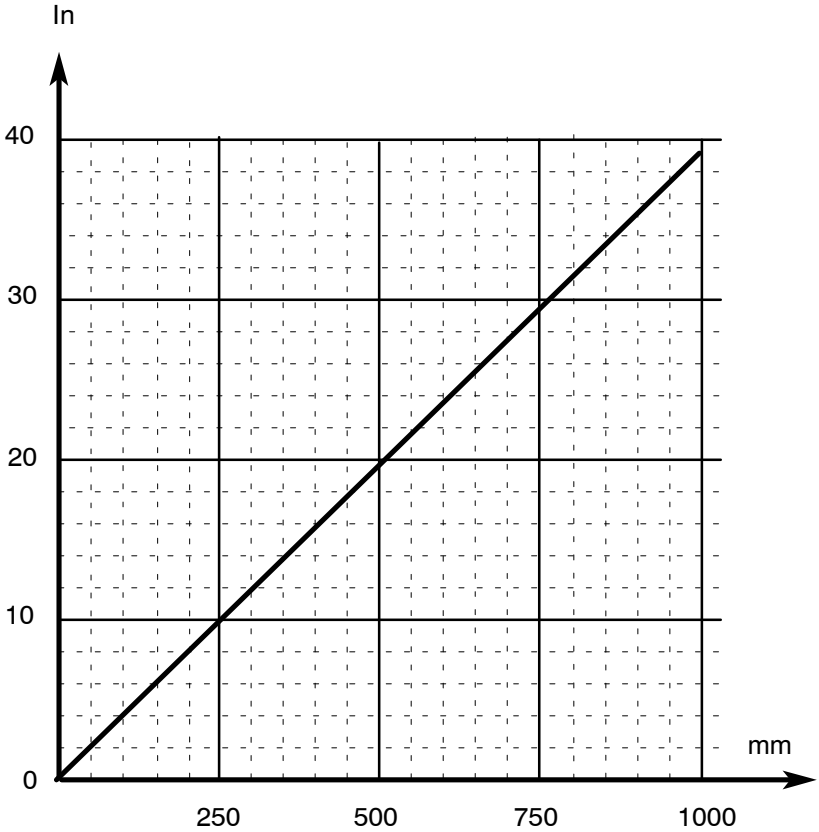

Figure 1.5.3 - INCHES VERSUS MILLIMETRES

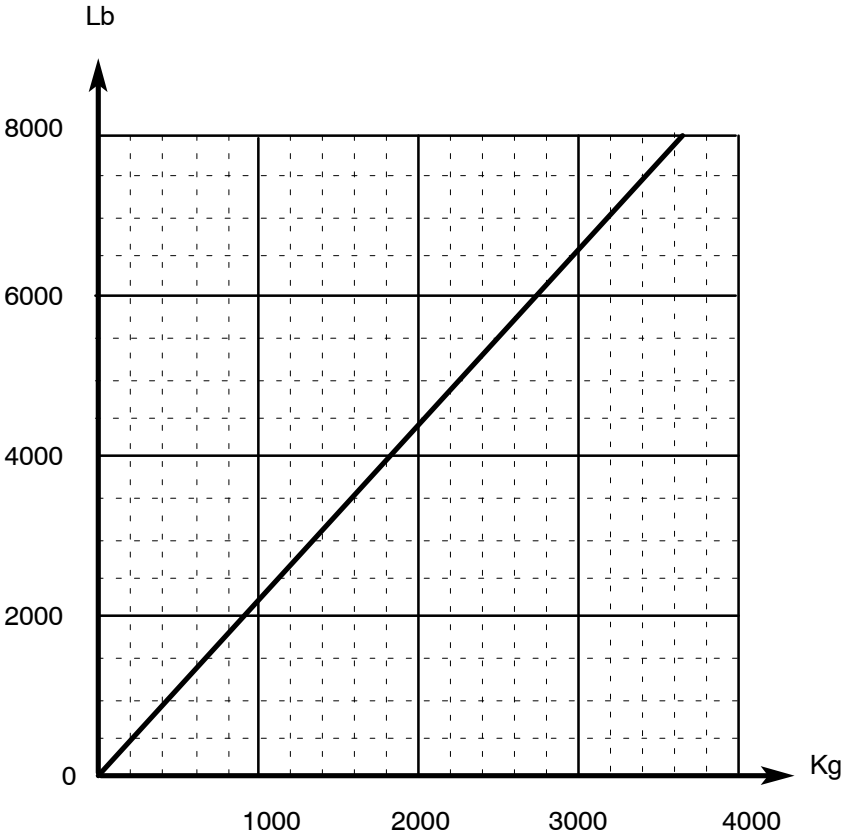

Figure 1.5.4 - POUNDS VERSUS KILOGRAMS

1.6 - PRESSURE AND STANDARD ATMOSPHERE

STANDARD ATMOSPHERE

Pressure altitude (ft)	Pressure (hPa)	°C	°F
0	1013.2	+ 15.0	+ 59.0
2000	942.1	+ 11.0	+ 51.8
4000	875.0	+ 7.0	+ 44.6
6000	811.9	+ 3.1	+ 37.6
8000	752.6	- 0.8	+ 30.5
10000	696.8	- 4.8	+ 23.4
12000	644.3	- 8.7	+ 16.2
14000	595.2	- 12.7	+ 9.2
16000	549.1	- 16.6	+ 2.2
18000	505.9	- 20.6	- 5.0
20000	465.6	- 24.6	- 12.4
22000	427.8	- 28.5	- 19.3
24000	392.6	- 32.5	- 26.5
26000	359.8	- 36.5	- 33.6
28000	329.3	- 40.4	- 40.7
30000	300.8	- 44.4	- 47.8
31000	287.4	- 46.4	- 51.6

Figure 1.6.1 - STANDARD ATMOSPHERE

PRESSURE CONVERSION TABLE

NOTE :

The standard pressure of 1013.2 hPa is equal to 29.92 inches of mercury.

950 28.05	951 28.08	952 28.11	953 28.14	954 28.17	955 28.20	956 28.23	957 28.26	958 28.29	959 28.32
960 28.35	961 28.38	962 28.41	963 28.44	964 28.47	965 28.50	966 28.53	967 28.56	968 28.58	969 28.61
970 28.64	971 28.67	972 28.70	973 28.73	974 28.76	975 28.79	976 28.82	977 28.85	978 28.88	979 28.91
980 28.94	981 28.97	982 29.00	983 29.03	984 29.06	985 29.09	986 29.12	987 29.15	988 29.18	989 29.20
990 29.23	991 29.26	992 29.29	993 29.32	994 29.35	995 29.38	996 29.41	997 29.44	998 29.47	999 29.50
1000 29.53	1001 29.56	1002 29.59	1003 29.62	1004 29.65	1005 29.68	1006 29.71	1007 29.74	1008 29.77	1009 29.80
1010 29.83	1011 29.85	1012 29.88	1013 29.91	1014 29.94	1015 29.97	1016 30.00	1017 30.03	1018 30.06	1019 30.09
1020 30.12	1021 30.15	1022 30.18	1023 30.21	1024 30.24	1025 30.27	1026 30.30	1027 30.33	1028 30.36	1029 30.39
1030 30.42	1031 30.45	1032 30.47	1033 30.50	1034 30.53	1035 30.56	1036 30.59	1037 30.62	1038 30.65	1039 30.68
1040 30.71	1041 30.74	1042 30.77	1043 30.80	1044 30.83	1045 30.86	1046 30.89	1047 30.92	1048 30.95	1049 30.98

Figure 1.6.2 - PRESSURE CONVERSION TABLE

SECTION 2

LIMITATIONS

TABLE OF CONTENTS

	Page
2.1 GENERAL	2.1.1
2.2 AIRSPEED LIMITATIONS	2.2.1
2.3 POWERPLANT LIMITATIONS	2.3.1
ENGINE	2.3.1
OIL	2.3.1
FUEL	2.3.2
PROPELLER	2.3.3
2.4 STARTER OPERATION LIMITS	2.4.1
2.5 WEIGHT AND C.G. LIMITS	2.5.1
WEIGHT LIMITS	2.5.1
C.G. LIMITS	2.5.1
2.6 OPERATION LIMITS	2.6.1
MANEUVER LIMITS	2.6.1
TEMPERATURE LIMITS	2.6.1
FLIGHT LOAD FACTOR LIMITS	2.6.1
SEVERE ICING CONDITIONS	2.6.2
FLAP OPERATING ENVELOPE	2.6.3
REVERSE UTILIZATION	2.6.3
EQUIPMENT REQUIRED DEPENDING ON TYPE OF OPERATION ...	2.6.3
ALTITUDE OPERATING LIMITS	2.6.7
IN-FLIGHT CIRCUIT BREAKER USE LIMITS	2.6.7

TABLE OF CONTENTS
(Continued)

	Page
2.7 MISCELLANEOUS LIMITS	2.7.1
SEATING LIMITS C.G.	2.7.1
BAGGAGE LIMITS	2.7.1
MINIMUM CREW	2.7.1
MAXIMUM OCCUPANCY	2.7.1
USE OF DOORS	2.7.1
ENGINE TREND MONITORING	2.7.1
CHEMICAL TOILET CABINET	2.7.1
2.8 MARKINGS	2.8.1
AIRSPEED INDICATOR	2.8.1
PRESSURIZATION	2.8.1
ENGINE INSTRUMENTS	2.8.2
SUCTION GAGE	2.8.2
2.9 PLACARDS	2.9.1

2.1 - GENERAL

The TBM 700 airplane is certified in the Normal Category.

This airplane must be flown in compliance with the limits specified by placards or markings and with those given in this Section and throughout the Pilot's Operating Handbook.

This Section of the airplane Pilot's Operating Handbook presents the various operating limitations, the significance of such limitations, instrument markings, color coding, and basic placards necessary for the safe operation of the airplane, its powerplant and installed equipment.

The limitations for optional systems are given in Section 9, "Supplements" of the Pilot's Operating Handbook.

INTENTIONALLY LEFT BLANK

2.2 - AIRSPEED LIMITATIONS

Airspeed limitations and their operational significance are shown in Figure 2.2.1.

	SPEED	KCAS	KIAS	REMARKS
V_{MO}	Maximum operating speed	271	266	Do not intentionally exceed this speed in normal flight category
V_A	Maneuvering speed	160	158	Do not make abrupt or full control movements above this speed
V_{FE}	Maximum flaps extended speed : landing configuration takeoff configuration	120 180	122 178	Do not exceed these speeds depending on flaps position
V_{LO}	Maximum landing gear operating speed : extension retraction	180 130	178 128	Do not extend or retract landing gear above this speed
V_{LE}	Maximum landing gear extended speed	180	178	Do not exceed this speed with landing gear extended
	Maximum inertial separator operating speed	205	200	No limitation when inertial separator is in fixed position

Figure 2.2.1 - AIRSPEED LIMITATIONS

INTENTIONALLY LEFT BLANK

2.3 - POWERPLANT LIMITATIONS**ENGINE**

Number of engines : 1

Engine manufacturer : PRATT & WHITNEY CANADA

Engine model number : PT6A - 64

Engine operating limits for takeoff and continuous operations :

Maximum power :

- 700 SHP : MAX TRQ 100 % at Np = 2000 RPM
MAX TRQ 110 % at Np = 1800 RPM

Maximum power :

- Ng : 104.1 %
- Np : 2000 RPM

ITT :

- Anytime during engine operation :
 - . continuous : 800°C
- During start : 870°C for 20 seconds max.
1000°C for 5 seconds max.

CAUTION

**WHEN NORMALLY OPERATING, REFER TO CHAPTER 5.7
"ENGINE OPERATION" TABLES**

OIL**CAUTION**

DO NOT MIX DIFFERENT BRANDS OR TYPES OF OIL

Maximum oil temperature : 104 °C

Oil pressure :

- Minimum : 60 psi
- Maximum : 135 psi

Oil capacity :

- System total capacity : 12.7 Quarts (12 Litres) (Oil cooler included)
- Usable capacity : 6 Quarts (5.7 Litres)

Oil grade (Specification) :

Nominal viscosity	US specification (US)	French specification (FR)	English specification (UK)	NATO code
Type 5cSt	MIL-L-23699C Amdt 1	MIL-L-23699C Amdt 1	DERD 2499 Issue 1	O.156

Figure 2.3.1 – ENGINE OIL RECOMMENDED TYPE
(Reference : Service Bulletin P & W C. No. 14001)

FUEL

Fuel pressure :

Minimum : 10 psi

Maximum : 50 psi

Fuel limitations :

2 tanks : 145.3 us gal (550 Litres) each

Total fuel : 290.6 us gal (1100 Litres)

Usable fuel : 281.6 us gal (1066 Litres)

Unusable fuel : 9 us gal (34 Litres)

Maximum fuel unbalance : 25 us gal (95 Litres)

NOTE :

Usable fuel can be safely used during all normal airplane maneuvers.

CAUTION

THE FUEL USED MUST CONTAIN AN ANTI-ICE ADDITIVE, IN ACCORDANCE WITH SPECIFICATION MIL-I-27686 OR MIL-I-85470. ADDITIVE CONCENTRATIONS (EGME OR DIEGME) SHALL BE COMPRISED BETWEEN A MINIMUM OF 0.06 % AND A MAXIMUM OF 0.15 % BY VOLUME. REFER TO SECTION 8 "HANDLING, SERVICING AND MAINTENANCE" FOR ADDITIONAL INFORMATION

CAUTION

THE USE OF AVIATION GASOLINE (AVGAS) MUST BE RESTRICTED TO EMERGENCY PURPOSES ONLY. AVGAS SHALL NOT BE USED FOR MORE THAN 150 CUMULATIVE HOURS DURING ANY PERIOD BETWEEN ENGINE OVERHAUL PERIODS

NOTE :

Use of AVGAS to be recorded in engine module logbook.

US Specification (US)	French Specification (FR)	English Specification (UK)	NATO Code
ASTM-D1655 JET A ASTM-D1655 JET A1 ASTM-D1655 JET B	AIR 3405C Grade F35	DERD 2494 Issue 9	F35 without additive
MIL-DTL-5624 Grade JP-4	AIR 3407B	DERD 2454 Issue 4 Amdt 1	F40 with additive
MIL-DTL-5624 Grade JP-5	AIR 3404C Grade F44	DERD 2452 Issue 2 Amdt 1	F44 with additive when utilization
MIL-DTL-83133 Grade JP-8	AIR 3405C Grade F34	DERD 2453 Issue 4 Amdt 1	F34 with additive S748
	AIR 3404C Grade F43	DERD 2498 Issue 7	F43 without additive

Figure 2.3.2 - RECOMMENDED FUEL TYPES
(Reference : Service Bulletin P & W C. No. 14004)

PROPELLER

Number of propellers : 1

Propeller manufacturer : HARTZELL

Propeller model number : HC-E4N-3 / E9083S (K)

Propeller diameter :

Minimum : 90 inches (2.286 m)

Maximum : 91 inches (2.311 m)

Propeller blade setting at 30 inches station :

Low pitch : 21°

Feathering : 86°

Maximum reverse : - 11°

INTENTIONALLY LEFT BLANK

2.4 - STARTER OPERATION LIMITS

Starter operation sequence is limited as follows :

if $N_g \leq 30\%$ 30 seconds

if $N_g > 30\%$ 60 seconds

Should several sequences be necessary, respect following spacing :

1st sequence

wait 1 minute

2nd sequence

wait 5 minutes

3rd sequence

wait 30 minutes

4th sequence

INTENTIONALLY LEFT BLANK

2.5 - WEIGHT AND C.G. LIMITS

(Refer to Supplement 41 for TBM 700C2 airplane)

WEIGHT LIMITS

Maximum ramp weight (MRW) : 6614 lbs (3000 kg)

Maximum takeoff weight (MTOW) : 6579 lbs (2984 kg)

Maximum landing weight (MLW) : 6250 lbs (2835 kg)

Maximum zero fuel weight (MZFW) : 6001 lbs (2722 kg)

Maximum baggage weight in pressurized compartment : 220 lbs (100 kg)

Maximum baggage weight in non pressurized aft compart. : 77 lbs (35 kg)

C.G. LIMITS - see Figure 6.4.2

Center of gravity range with landing gear down and flaps up, attitude 0° :

Forward limits :

181.3 inches (4.604 m) aft of datum at 4409 lbs (2000 kg) or less (14 % of m.a.c)

183.6 inches (4.664 m) aft of datum at 6250 lbs (2835 kg) (18 % of m.a.c)

184.8 inches (4.694 m) aft of datum at 6579 lbs (2984 kg) (20 % of m.a.c)

Aft limits :

194.9 inches (4.951 m) aft of datum at all weights below 6250 lbs (2835 kg) (37 % of m.a.c.)

194.3 inches (4.936 m) aft of datum at 6579 lbs (2984 kg) (36 % of m.a.c.)

Reference datum : 118.1 inches (3 m) in front of the firewall front face.

Straight line variation between points.

Leveling point : Cabin floor rails.

NOTE :

It is the responsibility of the pilot to insure that the airplane is properly loaded. See Section 6 "Weight and Balance" for proper loading instructions.

INTENTIONALLY LEFT BLANK

2.6 - OPERATION LIMITS

MANEUVER LIMITS

This airplane is certified in the normal category.

The normal category is applicable to airplanes intended for non-aerobatic operations.

Non-aerobatic operations include any maneuvers incidental to normal flying, stalls (except whip stalls), lazy eights, chandelles, and steep turns in which the angle of bank is no more than 60°.

Aerobatic maneuvers, including spins, are not approved.

TEMPERATURE LIMITS

Minimum temperature at start and takeoff : - 40°C (- 40°F)

Maximum temperature at start and takeoff :
ISA + 37°C (+ 67°F) from 0 to 8000 ft pressure altitude

Maximum temperature in flight :
ISA + 37°C (+ 67°F) from 0 to 8000 ft pressure altitude
ISA + 30°C (+ 54°F) at 31000 ft pressure altitude
Linear decrease between 8000 and 31000 ft

Battery operation limit : 70°C (158°F) corresponding to "BAT OVHT" warning light illumination (if Cadmium-Nickel battery installed)

FLIGHT LOAD FACTOR LIMITS

(Refer to Supplement 41 for TBM 700C2 airplane)

Flaps up : - 1.5 ≤ n ≤ + 3.8 g

Flaps down : - 0 ≤ n ≤ + 2.0 g

CAUTION

INTENTIONAL NEGATIVE LOAD FACTORS PROHIBITED

SEVERE ICING CONDITIONS

WARNING

SEVERE ICING MAY RESULT FROM ENVIRONMENTAL CONDITIONS OUTSIDE OF THOSE FOR WHICH THE AIRCRAFT IS CERTIFICATED. FLIGHT IN FREEZING RAIN, FREEZING DRIZZLE, OR MIXED ICING CONDITIONS (SUPERCOOLED LIQUID WATER AND ICE CRYSTALS) MAY RESULT IN ICE BUILD-UP ON PROTECTED SURFACES EXCEEDING THE CAPABILITY OF THE ICE PROTECTION SYSTEM, OR MAY RESULT IN ICE FORMING AFT OF THE PROTECTED SURFACES. THIS ICE MAY NOT BE SHED USING THE ICE PROTECTION SYSTEMS, AND MAY SERIOUSLY DEGRADE THE PERFORMANCE AND CONTROLLABILITY OF THE AIRCRAFT

During flight, severe icing conditions that exceed those for which the aircraft is certificated shall be determined by the following visual cues. If one or more of these visual cues exists, immediately request priority handling from Air Traffic Control to facilitate a route or an altitude change to exit the icing conditions.

- Unusually extensive ice accumulation on the airframe and windshield in areas not normally observed to collect ice.
- Accumulation of ice on the upper surface of the wing aft of the protected area.

Since the autopilot, when operating, may mask tactile cues that indicate adverse changes in handling characteristics, use of the autopilot is prohibited when any of the visual cues specified above exist, or when unusual lateral trim requirements or autopilot trim warnings are encountered while the aircraft is in icing conditions.

Refer to the list of "Equipment required depending on type of operation" in this same chapter.

In any case of icing conditions, first refer to particular procedures described in Chapter 4.5 (normal procedures) and in case of unforeseen icing conditions, refer in addition to the emergency procedure described in Chapter 3.13.

FLAP OPERATING ENVELOPE

The use of flaps is not authorized above 15 000 ft.

REVERSE UTILIZATION

The use of control reverse BETA (β) range is prohibited :

- during flight,
- on ground, if the engine is not running.

EQUIPMENT REQUIRED DEPENDING ON TYPE OF OPERATION

The airplane is approved for day & night VFR and day & night IFR operations when appropriate equipment is installed and operating correctly.

The type certification for each use requires the following equipment. The equipment must be installed and operate perfectly according to the indicated type of use.

CAUTION

IT IS THE PILOT'S RESPONSIBILITY TO CHECK THAT THE FOLLOWING EQUIPMENT LISTS ARE IN ACCORDANCE WITH THE SPECIFIC NATIONAL OPERATION RULES OF THE AIRPLANE REGISTRATION COUNTRY DEPENDING ON THE TYPE OF OPERATION.

NOTE :

Systems and equipment mentioned hereafter do not include specific flight and radio-navigation instruments required by decree concerning operation conditions for civil airplanes in general aviation or other foreign regulations (for example FAR PART 91 and 135).

Day VFR

1) Pilot instruments

- Airspeed indicator
- Sensitive and adjustable altimeter
- Magnetic compass with built-in compensator

2) Warning lights

- Oil pressure
- Low fuel pressure
- Fuel selector OFF
- Fuel auxiliary pump ON
- L.H. and R.H fuel tank low level
- Non functioning of fuel timer
- Battery overheat
- Battery stop
- Main generator OFF
- Low voltage
- Ground power unit connected
- Inertial separator
- Starter
- Ignition
- Flaps
- Landing gears and doors

3) Aural warning

- V_{MO} warning
- Landing gear warning
- Stall warning

4) Engine instruments

- Torquemeter
- Propeller tachometer
- Interturbine temperature indicator (ITT)
- Gas generator tachometer (Ng)
- Oil pressure indicator
- Oil temperature indicator

5) Various indicators

- Fuel gauge indicators (2)
- Fuel pressure indicator
- Voltmeter
- Ammeter
- Outside air temperature

6) Installations

- Fuel mechanical pump (main)
- Fuel electrical pump (auxiliary)
- Fuel shut-off valve
- Fuel timer
- Starter generator
- Inertial separator
- Stall warning
- Electrical aileron trim
- Electrical rudder trim
- Manual elevator pitch trim
- Engine ignition
- Landing gear electro-hydraulic unit
- Landing gear emergency hydraulic pump (manual)
- Flaps
- Overspeed regulator
- Manual feathering
- Battery

7) Miscellaneous

- Seats (each occupant)
- Belts (each occupant)
- Straps (each occupant)
- Pilot's operating handbook

Night VFR

- 1) All equipment required for day VFR
- 2) Attitude display indicator
- 3) Instrument lighting
- 4) Instrument panel lighting
- 5) Emergency lighting
- 6) Vertical speed indicator
- 7) Navigation lights (4)
- 8) Anticollision lights (2)
- 9) Landing light

IFR

- 1) All equipment required for day VFR
- 2) All equipment required for night VFR (if flight is performed during night)
- 3) Taxi light (if flight is performed during night)
- 4) Clock
- 5) 2nd altimeter
- 6) Emergency static source
- 7) Pitot static tube deicing

Pressurized flight

- Cabin altimeter
- Cabin vertical speed indication
- Cabin differential pressure indication
- Pressurization control valve
- Safety valve
- Pressurization control
- Maximum cabin altitude and pressure warning light

Flight into icing conditions

- All equipment required for IFR flight
- Propeller deicing
- L.H. windshield deicing
- Airframe, stabilizer and elevator horn deicing
- Wing leading edge inspection light (if night flight)
- Stall warning deicing
- Inertial separator

ALTITUDE OPERATING LIMITS

Maximum altitude : 31000 ft (9449 m)

Maximum differential pressure : 6.2 psi

Operation in RVSM area

Reduced Vertical Separation Minima (RVSM) are met pending airplane compliance with SB 70-120-34.

Airworthiness Approval alone does not authorize flight into airspace for which an RVSM Operational Approval is required by an ICAO Regional Navigation Agreement.

NOTE :

Only altimeters AM250 are compliant with TBM 700 operation in RVSM area.

IN-FLIGHT CIRCUIT BREAKER USE LIMITS

A tripped circuit breaker should not be reset in flight unless deemed necessary for continued safe flight and landing. Only one reset should be attempted.

INTENTIONALLY LEFT BLANK

2.7 - MISCELLANEOUS LIMITS

SEATING LIMITS C.G.

- 2 seats at 180.5 inches (4.585 m)
- 2 seats at 222.1 inches (5.641 m)
- 2 seats at 272.3 inches (6.916 m)

BAGGAGE LIMITS

- Baggage in pressurized cabin at 303 inches (7.695 m)
- Rear baggage at 329.4 inches (8.366 m)

MINIMUM CREW

- One pilot

MAXIMUM OCCUPANCY

The number of persons on board is limited by approved seating configuration installed but must not exceed six, including the pilot.

USE OF DOORS

Flight with door open or ajar is prohibited.

ENGINE TREND MONITORING

The information related to navigation and flight parameters are a recopy of the airplane instruments and must not be used as primary means of flight control.

The ETM Operation Manual, at its latest revision, must be easily accessible to the pilot each time the ETM system is used.

CHEMICAL TOILET CABINET (if installed)

The cabinet must be stowed during take-off and landing. No baggage on the top of the cabinet for the whole flight.

INTENTIONALLY LEFT BLANK

2.8 - MARKINGS

AIRSPEED INDICATOR

(Refer to Supplement 41 for TBM 700C2 airplane)

Airspeed indicator markings and their color code significance are shown in Figure 2.8.1.

MARKING	KIAS (Value or range)	SIGNIFICANCE
White arc	60 - 122	Full Flap Operating Range Lower limit is maximum weight V_{SO} in landing configuration. Transition point between wide and narrow arcs is stall speed with flaps UP. Upper limit is maximum speed permissible with flaps LDG.
Wide	60 - 75	
Narrow	75 - 122	
Red line	266	Maximum speed for all operations

Figure 2.8.1 - AIRSPEED INDICATOR MARKINGS

PRESSURIZATION

MARKING	VALUE	SIGNIFICANCE
Red line	6.2 psi	Cabin ΔP limit

Figure 2.8.2 - PRESSURIZATION MARKING

ENGINE INSTRUMENTS

Engine instrument markings and their color code significance are shown in Figure 2.8.3.

INSTRUMENT	Red Line or arc ----- Minimum Limit	Yellow Line or Arc ----- Caution Range	Green Arc ----- Normal Operating	Red Line ----- Maximum Limit
Oil temperature	- 40 °C	- 40 to 0 °C 104 to 110 °C	0 to 104 °C	110 °C
Oil pressure	60 psi	60 to 100 psi	100 to 135 psi	135 psi
Fuel pressure	0 to 5 psi	---	10 to 50 psi	50 psi
Generator RPM (Ng)	---	---	51 to 104 %	104 %
Propeller RPM (Np)	---	450 to 1000 RPM	1600 to 2000 RPM	2000 RPM
ITT	---	800 to 1090 °C	400 to 800 °C	800 °C normal limit ----- 1090 °C (red triangle) absolute limit
Torque (TRQ)	---	100 %	0 to 110 % (arc ½ thick from 100 to 110 %)	110 %

Figure 2.8.3 - ENGINE INSTRUMENT MARKINGS

SUCTION GAGE

MARKING	CORRESPONDING VALUE
Green	Normal operating from 4.4 to 5.2 in.Hg
Red lines	at 4.4 and 5.2 in.Hg

Figure 2.8.4 - SUCTION GAGE MARKINGS

2.9 - PLACARDS

(1) Under L.H. front side window *

I4113004AAAKMA8200

FLIGHT CONDITIONS :
DAY AND NIGHT VFR AND IFR

TBM700 C1

THIS AIRPLANE MUST BE OPERATED AS A NORMAL CATEGORY AIRPLANE
IN COMPLIANCE WITH THE OPERATING LIMITATIONS STATED IN THE FORM
OF PLACARDS, MARKINGS AND PILOT OPERATING HANDBOOK

ICING CONDITIONS ALLOWED

<p>INVERTED FLIGHT _____ PROHIBITED</p> <p>ACROBATIC MANEUVERS _____ PROHIBITED</p> <p>INTENTIONAL SPINS _____ PROHIBITED</p> <p>MAXIMUM TAKEOFF WEIGHT _____ 2984 kg / 6579 lbs</p> <p>MAXIMUM LANDING WEIGHT _____ 2835 kg / 6250 lbs</p> <p>DESIGN LOAD FACTOR (MAXIMUM)</p> <p>FLAPS UP _____ $-1.5 < n < +3.8$ g</p> <p>FLAPS DOWN _____ $0 < n < +2$ g</p>	<p>MANEUVERING SPEED V_A _____ 158 KIAS</p> <p>MAXIMUM OPERATING SPEED V_{MO} _____ 266 KIAS</p> <p>FLAPS EXTENDED MAXIMUM SPEED V_{FE} _____</p> <p>TAKEOFF CONFIGURATION _____ 178 KIAS</p> <p>LANDING CONFIGURATION _____ 122 KIAS</p> <p>LANDING GEAR EXTENDED MAXIMUM SPEED V_{LE} _____ 178 KIAS</p> <p>LANDING GEAR OPERATING MAXIMUM SPEED V_{LO}</p> <p>UP _____ 128 KIAS</p> <p>DOWN _____ 178 KIAS</p>
--	--

(2) Calibration chart on compass and on windshield post

WARNING

**TURN L AND R WINDSHIELD
DE-ICE OFF BEFORE
COMPASS READING**

For	N	30	60	E	120	150
Steer						
For	S	210	240	W	300	330
Steer						

DATE : _____ RADIO ON _____

(*) Refer to Supplement 41 for TBM 700C2 airplane

(3) On pressurized baggage compartment partition wall *

I4112003AAA BMA18000

100 kg - 220 lbs MAXIMUM

IT IS THE PILOT'S RESPONSIBILITY TO CHECK THAT ALL THE BAGGAGES ARE PROPERLY SECURED.

FOR LOADING INSTRUCTIONS SEE "WEIGHT AND BALANCE DATA" IN PILOT'S OPERATING HANDBOOK

or

I4112003AAA BMA8200

100 kg - (220 lbs) MAXIMUM

IT IS THE PILOT'S RESPONSIBILITY TO CHECK THAT ALL THE BAGGAGES ARE PROPERLY SECURED.

FOR LOADING INSTRUCTIONS SEE "WEIGHT AND BALANCE DATA" IN PILOT'S OPERATING HANDBOOK AND GRAPH OPPOSITE.

100	220
85	187
25	55
35	77

CABIN COMPARTMENT

REAR COMPARTMENT

(*) Refer to Supplement 41 for TBM 700C2 airplane

(4) Under radio rack, in front of pedestal

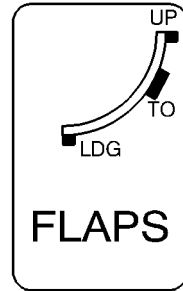
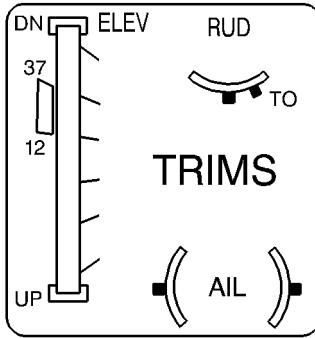

NOSE
DOWN



NOSE
UP

14113006AAALMA8201

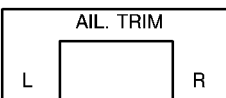

POWER
TR
X
I
N
V
E
R
S
E

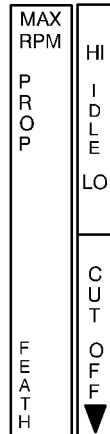

FLAPS

UP
TO
LDG

(5) On fuel selector

I4113006AAAALMA8100

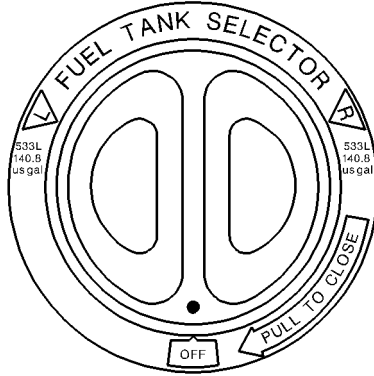

(6) Near fuel tank caps

JET-A-FUEL
TOTAL CAPACITY 145.3 us gal - 550 l
ANTHICE ADDITIVE REQUIRED.SEE PILOT'S
OPERATING HANDBOOK FOR OTHER APPROVED
FUELS QUANTITY AND TYPE OF ADDITIVE

I4112004AAAAAMA8000

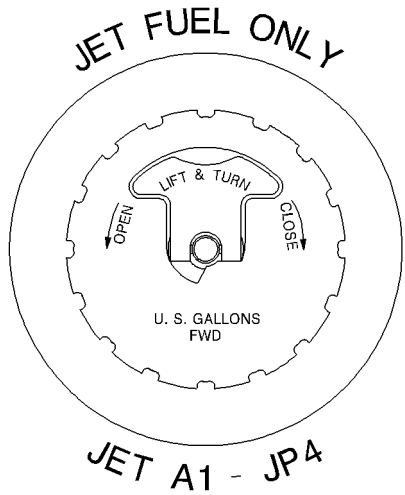

- (7) On internal face of L.H. engine cowling

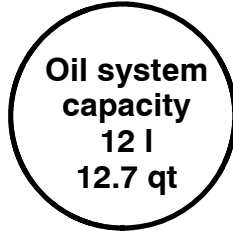

- (8) On landing gear emergency control access door

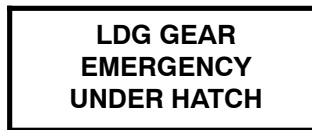

- (9) On rear passenger's table casing



- (10) Under R.H. control wheel

I4113006AAA/KMA8000

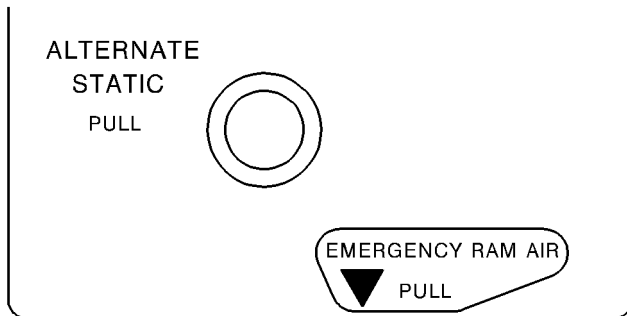

(11) On nose gear door

14112001AAACMA8000

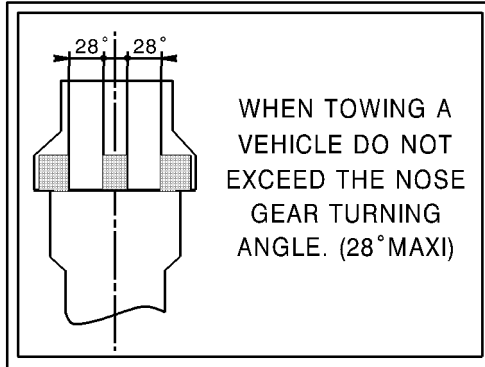

(12) On nose gear leg

**NOSE LANDING GEAR
TIRE PRESSURE : 6,5 bar
94 psi**

(13) On main gear leg *

**MAIN LANDING GEAR
TIRE PRESSURE : 8,25 bar
120 psi**

(14) On engine cowling, in front of compartment door

**EXTERNAL POWER
28 VOLTS D.C. NOMINAL
800 AMPS
STARTING CAPACITY MIN
DO NOT EXCEED 1400 AMPS**

(*) Refer to Supplement 41 for TBM 700C2 airplane

(15) On "pilot" door - External side (if installed)

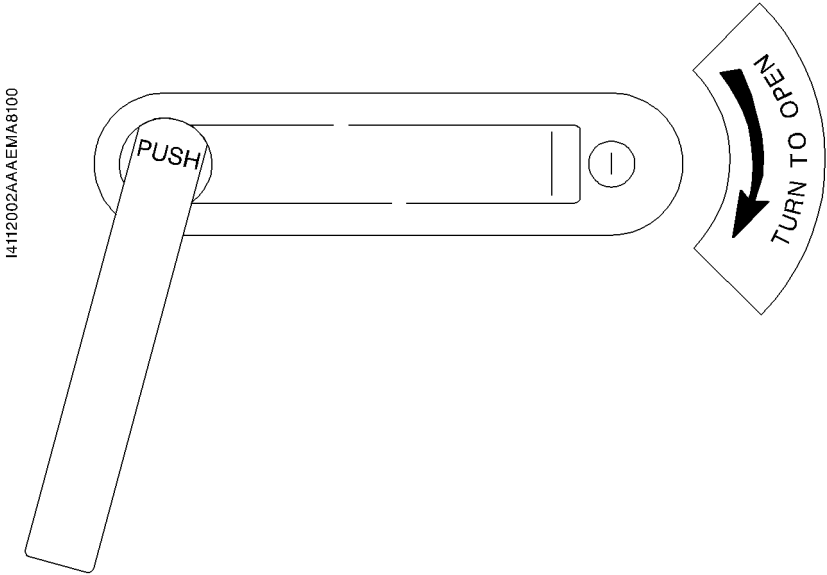

(16) On access door - External side

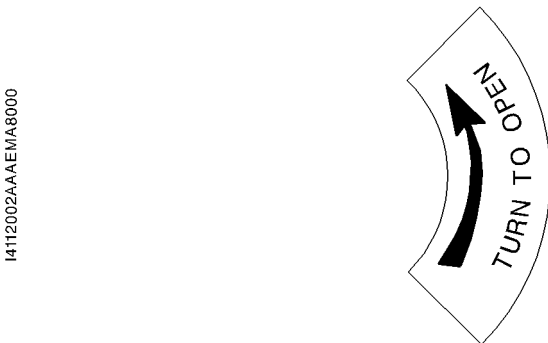

- (17) On outer fuselage skin aft of access door and in the cabin forward of access door

I4112002AAA DMA8000

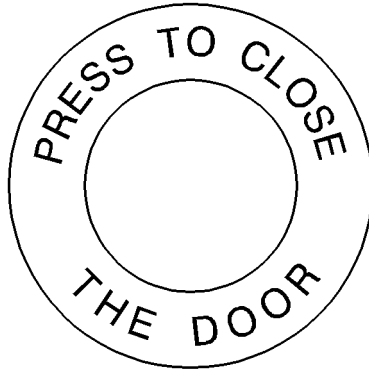

- (18) On access door - Internal side

I4112002AAA DMA8201



CAUTION: UNLOCK BEFORE
OPERATING THE HANDLE

TURN HANDLE
TO OPEN



(19) On "pilot" door – Internal side (if installed)

I4T12002AAADMA8101



(20) On emergency exit handle

Marking on cover

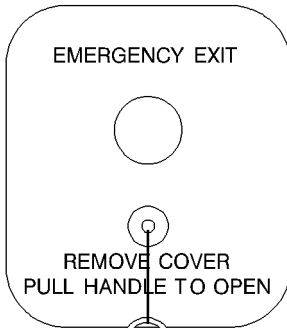

Marking on handle

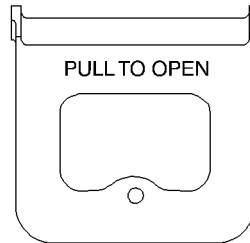

M45Z1000AALLMAFV00

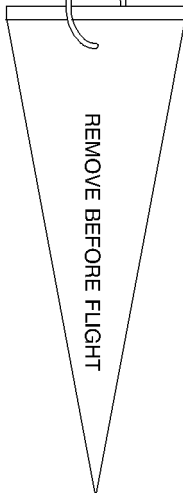

(21) On last step of stairs

STAIRS MAX LOAD : ONE PERSON

(22) On R.H. access door jamb

**DO NOT USE
HAND RAIL
TO RETRACT
OR STOW
STAIRS**

(23) On R.H. side at front seat level and on the first rear passengers masks container (R.H. side on the ceiling)

I4113400AAA BMA8000

WARNING
GREASY SUBSTANCES ARE CAPABLE
OF SPONTANEOUS COMBUSTION
ON CONTACT WITH OXYGEN
DO NOT SMOKE WHILE OXYGEN IS IN USE

(24) On rear passengers masks containers (on R.H. side on the ceiling)

I4113400AAA BMA8101

OXYGEN MASKS INSIDE
PULL MASKS FOR
OXYGEN SUPPLY ↓

(25) On internal face of the oxygen cylinder service door

I4112400AAAAA8000

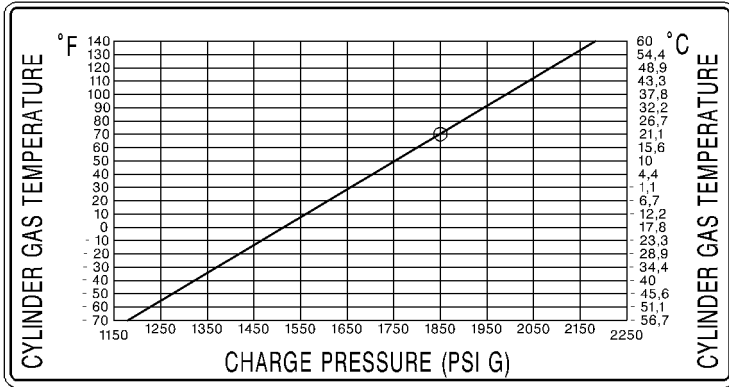

(26) On the oxygen service door

I4112400AAAAA8100

**OXYGEN SERVICE POINT
USE NO LUBRICANTS**

(27) On internal face of L.H. engine cowl

I4112001AAADMA8000

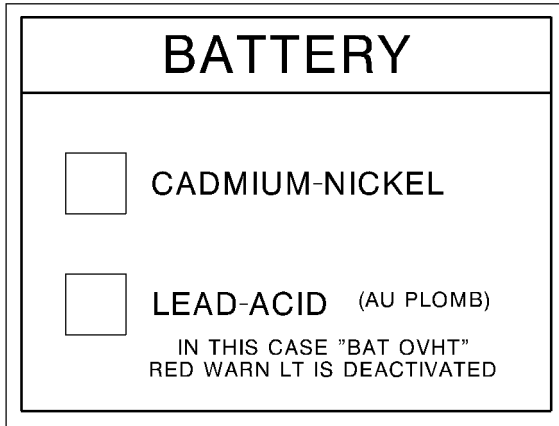

(28) On internal face of the door of the rear baggage compartment (non pressurized)

I4112003AAABMA8000

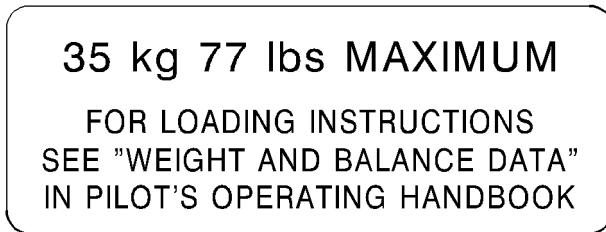

or

I4112003AAABMA8100

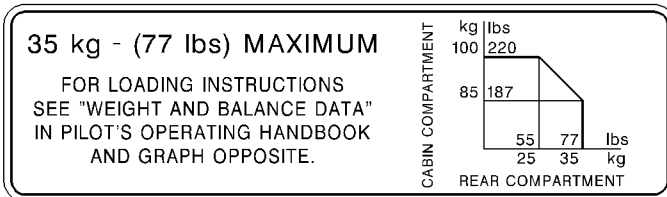

(29) On emergency locator transmitter inspection door

I4112200AAAAA/MA8000



(30) On the potty seat curtain (if installed), on pilot's side

CURTAIN MUST BE STOWED FOR TAKE-OFF AND LANDING

Post-MOD70-0391-26D

(31) On R.H. side at front seat level

I4113207AAAA/MA8300

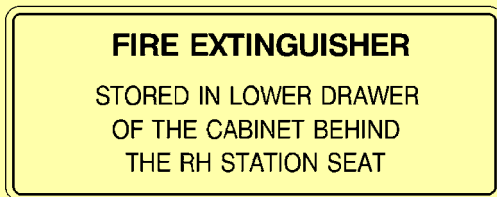

(32) On the lower drawer of the R.H. cabinet

I4113207AAAA/MA8000

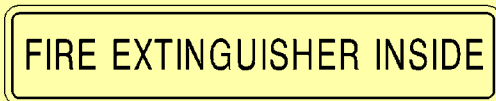

(29) On emergency locator transmitter inspection door

I4112200AAAAMA8000



(30) On the potty seat curtain (if installed), on pilot's side

CURTAIN MUST BE STOWED FOR TAKE-OFF AND LANDING

INTENTIONALLY LEFT BLANK

SECTION 3

EMERGENCY PROCEDURES

TABLE OF CONTENTS

		Page
3.1	GENERAL	3.1.1
3.2	REJECTED TAKEOFF PROCEDURE	3.2.1
3.3	ENGINE FAILURES	3.3.1
	ENGINE FAILURE AT TAKEOFF BEFORE ROTATION	3.3.1
	ENGINE FAILURE AFTER ROTATION	3.3.2
	ENGINE FAILURE DURING FLIGHT	3.3.3
	OIL PRESSURE DROP	3.3.4
	ENGINE REGULATION DISCREPANCY, POWER LOSS, POWER LEVER CONTROL LOSS	3.3.5
	GOVERNOR REGULATION CONTROL NOT OPERATING	3.3.7
	EXCESSIVE PROPELLER ROTATION SPEED	3.3.8
	RED WARNING LIGHT ITT ON	3.3.9
	ENGINE DOES NOT STOP ON GROUND	3.3.11
3.4	AIR START	3.4.1
	AIR START ENVELOPE	3.4.1
	AIR START WITH STARTER	3.4.2
3.5	FIRE AND SMOKE	3.5.1
	ENGINE FIRE ON GROUND	3.5.1
	CABIN FIRE ON GROUND	3.5.1
	ENGINE FIRE IN FLIGHT	3.5.2
	CABIN ELECTRICAL FIRE OR SMOKE DURING FLIGHT	3.5.3
	SMOKE ELIMINATION	3.5.5

TABLE OF CONTENTS
(Continued)

		Page
3.6	EMERGENCY DESCENTS	3.6.1
	MAXIMUM RATE DESCENT	3.6.2
	MAXIMUM RANGE DESCENT	3.6.2
3.7	EMERGENCY LANDINGS	3.7.1
	FORCED LANDING (ENGINE CUT OFF)	3.7.1
	TIRE BLOWOUT DURING LANDING	3.7.2
	LANDING WITH UNLOCKED MAIN LANDING GEAR	3.7.3
	LANDING WITH DEFECTIVE NOSE LANDING GEAR (DOWN UNLOCKED OR NOT DOWN)	3.7.5
	LANDING WITH GEAR UP	3.7.6
	LANDING WITHOUT ELEVATOR CONTROL	3.7.7
	LANDING WITH FLAPS MALFUNCTION	3.7.8
	DITCHING	3.7.9
3.8	FUEL SYSTEM	3.8.1
	RED WARNING LIGHT FUEL PRESS ON	3.8.1
	AMBER WARNING LIGHT AUX BP ON ON	3.8.3
	AMBER WARNING LIGHT FUEL L. LO OR FUEL R. LO ON	3.8.4
	AMBER WARNING LIGHT AUTO SEL ON	3.8.4
3.9	ELECTRICAL SYSTEM	3.9.1
	RED WARNING LIGHT BAT OVHT ON (if Cadmium-Nickel battery installed)	3.9.1
	AMBER WARNING LIGHT BAT OFF ON	3.9.1
	AMBER WARNING LIGHT MAIN GEN ON	3.9.2

TABLE OF CONTENTS

(Continued)

		Page
AMBER WARNING LIGHT	LO VOLT	ON
normal functioning on "MAIN GEN"		3.9.3
AMBER WARNING LIGHT	LO VOLT	ON
functioning on "ST-BY GENERATOR" (after "MAIN GEN" failure)		3.9.4
ELECTRICAL DISTRIBUTION OF BUS BARS		3.9.7
"RADIO MASTER" SWITCH FAILURE		3.9.9
3.10 PRESSURIZATION AND AIR CONDITIONING		3.10.1
RED WARNING LIGHT	CAB PRESS	ON
CABIN NOT DEPRESSURIZED AFTER LANDING		3.10.1
AMBER WARNING LIGHT	BLEED OFF	ON
.....		3.10.2
RED WARNING LIGHT	BLEED TEMP	ON
.....		3.10.3
RED WARNING LIGHT	DOOR	ON
.....		3.10.4
AMBER WARNING LIGHT	VACUUM LO	ON
.....		3.10.5
DEFOG MALFUNCTION		3.10.6
3.11 LANDING GEAR AND FLAPS		3.11.1
LANDING GEAR RETRACTION DISCREPANCY		3.11.1
LANDING GEAR EXTENSION DISCREPANCY		3.11.2
EMERGENCY GEAR EXTENSION		3.11.3
RED WARNING LIGHT	FLAPS	ON
.....		3.11.5
FLAPS MALFUNCTION		3.11.5

TABLE OF CONTENTS
 (Continued)

	Page
3.12 DEICING SYSTEM	3.12.1
LEADING EDGES DEICING FAILURE	3.12.1
PROPELLER DEICING FAILURE	3.12.1
INERTIAL SEPARATOR FAILURE	3.12.2
WINDSHIELD DEICING FAILURE	3.12.2
WINDSHIELD MISTING OR INTERNAL ICING	3.12.3
AMBER WARNING LIGHT PITOT 1 PITOT 2	
OR STALL HTR ON	3.12.4
3.13 MISCELLANEOUS	3.13.1
RUNAWAY OF ONE OF THE THREE ELECTRICAL TRIM TABS	3.13.1
CRACK IN COCKPIT WINDOW OR WINDOW PANEL	3.13.1
EMERGENCY EXIT USE	3.13.2
EMERGENCY BEACON USE (ELT)	3.13.2
TOTAL COMMUNICATION FAILURE	3.13.3
MAIN GYRO HEADING FAILURE	3.13.3
PARTICULAR TRANSPONDER USES	3.13.4
ACCIDENTAL SPINS	3.13.4
OXYGEN USE	3.13.5
AIRSPEED INDICATING SYSTEM FAILURE	3.13.7
FLIGHT INTO SEVERE ICING CONDITIONS	3.13.8

3.1 - GENERAL

The recommended procedures for different failures or emergency situations are provided in this Section.

Emergency procedures associated with optional or particular equipment which require pilot's operating handbook supplements are provided in Section 9 "Supplements".

Pilot must know procedures given in this section and be prepared to take appropriate action should an emergency arise.

Some emergency procedures are a part of pilot basic training. Although these emergencies are discussed here, this information is not intended to replace such training, but only to provide a source of reference and review. This information also provides failure procedures which are not the same for all airplanes.

It is important for the pilot to be familiar with standard emergency procedures to be at the optimum efficacy if necessary.

Alarm system recall

Main failure or state modification of the different systems are provided by an advisory panel.

This panel includes **red** warning lights indicating a failure which requires an immediate action from the pilot, and **amber** warning lights indicating failures or discrepancies which require an action as soon as practical.

Red or amber failure warning are coupled with the lighting of

- a flashing red indicator



or - a flashing amber indicator



Both indicators are located on the upper part of the L.H. instrument panel. When either one lights up, press it once to reactivate, it will go out and is ready to signal in the event of another failure. On the warning light central panel, the corresponding failure warning light remains ON as long as the failed condition exists.

3.2 - REJECTED TAKEOFF PROCEDURE

Following an engine failure, refer to Chapter 3.3, Paragraph "ENGINE FAILURE AT TAKEOFF BEFORE ROTATION".

For any other reason :

- 1 - Power lever **IDLE**
- 2 - Reverse **AS REQUIRED**
- 3 - Braking **AS REQUIRED**

If the airplane cannot be stopped on the remaining runway :

- 4 - Power lever **IDLE**
- 5 - Condition lever **CUT OFF**
- 6 - Tank selector **OFF**
- 7 - CRASH lever **PULL DOWN**

Evacuate if necessary, after the airplane has come to a stop.

INTENTIONALLY LEFT BLANK

3.3 - ENGINE FAILURES

ENGINE FAILURE AT TAKEOFF BEFORE ROTATION

- | | |
|---|--------------------|
| 1 - Power lever | IDLE |
| 2 - Braking | AS REQUIRED |
| <i>If the airplane cannot be stopped on the remaining runway :</i> | |
| 3 - Condition lever | CUT OFF |
| 4 - Tank selector | OFF |
| 5 - CRASH lever | PULL DOWN |

3.3 - ENGINE FAILURES

ENGINE FAILURE AFTER ROTATION
(Refer to Supplement 41 for TBM 700C2 airplane)

**- If altitude does not allow to choose a favourable runway or field :
Land straight ahead keeping flaps at TO and without changing
landing gear position.**

Before touch-down :

- 1 - Maintain **IAS > 80 KIAS**
- 2 - Power lever **IDLE**
- 3 - Condition lever **CUT OFF**
- 4 - Tank selector **OFF**
- 5 - CRASH lever **PULL DOWN**

- If altitude allows to reach a favourable runway or ground :

- 1 - LDG **DN**
- 2 - Flaps **AS REQUIRED**
- 3 - Maintain **IAS > 100 KIAS, Flaps UP**
IAS > 90 KIAS, Flaps TO
- 4 - Power lever **IDLE**
- 5 - Propeller governor lever **FEATHER**

Before touch-down :

- 6 - Condition lever **CUT OFF**
- 7 - Tank selector **OFF**
- 8 - CRASH lever **PULL DOWN**

3.3 - ENGINE FAILURES

ENGINE FAILURE DURING FLIGHT

- 1 - If AP engaged :
"AP / TRIM DISC INT" push-button **PRESSED**
- 2 - Power lever **IDLE**
- 3 - Propeller governor lever **FEATHER**
- 4 - Condition lever **CUT OFF**
- 5 - Remaining fuel **CHECK**
- 6 - Tank selector **SWITCH TANKS**
- 7 - "AUX BP" switch
and fuel pressure **CHECK / CORRECT**
- 8 - Air start (Refer to Chapter 3.4)
- 9 - In case of high altitude (above 12000 ft), undertake an
EMERGENCY DESCENT (Refer to Chapter 3.6)
- 10 - If air start not successful, perform a FORCED LANDING (Refer to
Chapter 3.7)

3.3 - ENGINE FAILURES

OIL PRESSURE DROP

RED WARNING LIGHT **OIL PRESS** ON

- 1 - Oil pressure indicator **CHECK**
- 2 - If the indicated pressure is correct **SHORTEN THE FLIGHT / MONITOR**
- 3 - If indicated pressure is below the green arc **CONFIRMED FAILURE**

Due to the oil pressure drop, the propeller blade angle may go towards high pitch and therefore lead to a Np propeller rotation speed decrease.

CAUTION

PREPARE FOR AN ENGINE STOP, SHORTLY ; REDUCE POWER TO THE MINIMUM NECESSARY, LAND AS SOON AS PRACTICAL

If engine power drops itself :

- 4 - Power lever **IDLE**
- 5 - Propeller governor lever **FEATHER**
- 6 - Condition lever **CUT OFF**

Perform a **FORCED LANDING** (Refer to Chapter 3.7)

3.3 - ENGINE FAILURES

**ENGINE REGULATION DISCREPANCY,
POWER LOSS,
POWER LEVER CONTROL LOSS (1/2)**

- 1 - If circumstances allow :
Power lever **IDLE**
- 2 - Confirm engine still running
- 3 - Tank selector **SWITCH TANKS**
- 4 - Check that no parameter exceeds allowed values
- 5 - "MAN OVRD" control **ACTUATED**
progressively forward
(Adjust power necessary to continue flight)

If the available power is weak, extend the landing gear only on a glide path in final approach and extend full flaps only in short final. Do not perform a go-around.

CAUTION

IN "MANUAL OVERRIDE" ENGINE IS NEITHER PROTECTED AGAINST SLAM ACCELERATIONS, NOR AGAINST MAXIMUM SPEED OVERSHOOTING. AVOID RAPID CONTROL MOVEMENTS AND MANAGE ENGINE PARAMETERS

CAUTION

IN SOME CASES, WHEN "MANUAL OVERRIDE" CONTROL IS USED, THE AVAILABLE POWER MAY NOT BE SUFFICIENT TO ENSURE A GO-AROUND IN LANDING CONFIGURATION, IN PARTICULAR IF THE WEIGHT IS NEAR THE MAXIMUM WEIGHT

- 6 - Continue flight, **SHORTEN** if possible



3.3 - ENGINE FAILURES

**ENGINE REGULATION DISCREPANCY,
POWER LOSS,
POWER LEVER CONTROL LOSS (2/2)**

- 7 - Perform a normal landing WITHOUT REVERSE
- 8 - Braking **AS REQUIRED**

If minimum power obtained is excessive :

- 1 - Reduce airspeed by setting airplane in nose-up attitude at IAS < 178 KIAS
- 2 - "INERT SEP" switch **ON**
- 3 - If ITT > 800°C :
"INERT SEP" switch **OFF**
- 4 - Landing gear control **DN**
- 5 - Flaps **TO**
- 6 - Establish a long final or an ILS approach respecting IAS < 178 KIAS
- 7 - When runway is assured :
Condition lever **CUT OFF**
- 8 - Propeller governor lever **FEATHER**
if necessary to extend trajectory
- 9 - Flaps **LDG as required**
(at IAS < 122 KIAS)
- 10 - Land normally WITHOUT REVERSE
- 11 - Braking **AS REQUIRED**

3.3 - ENGINE FAILURES

GOVERNOR REGULATION CONTROL NOT OPERATING

May indicate a rupture of the linkage of the governor control.

- 1 - Continue the flight.
- 2 - If $N_p < 2000$ RPM, do not perform a go-around and do not use the reverse.

In that case, the go-around performance and the reverse efficiency might be lower than expected. The airplane repair is mandatory before any other flight.

3.3 - ENGINE FAILURES

EXCESSIVE PROPELLER ROTATION SPEED

Indicates :

- a propeller governor failure

In that case, the propeller overspeed limiter will limit initially the rotation speed to 2100 RPM approximately.

- or a propeller governor and overspeed limiter failure

In that case, only the torque limiter operates to limit the power. However, the pilot intervention is necessary to maintain $N_p \leq 2000$ RPM. The propeller reducer is designed for a max. N_p of 2200 RPM.

- 1 - Reduce the power and the aircraft speed to avoid propeller rotation speeds higher than 2000 RPM.
- 2 - Land as soon as possible.
- 3 - Do not perform a go-around.

A go-around would damage the engine reduction gear box.

The airplane repair is mandatory before any other flight.

3.3 - ENGINE FAILURES

RED WARNING LIGHT ITT ON (1/2)

Indicates that ITT exceeds 800°C

During an engine start

Interturbine temperature °C

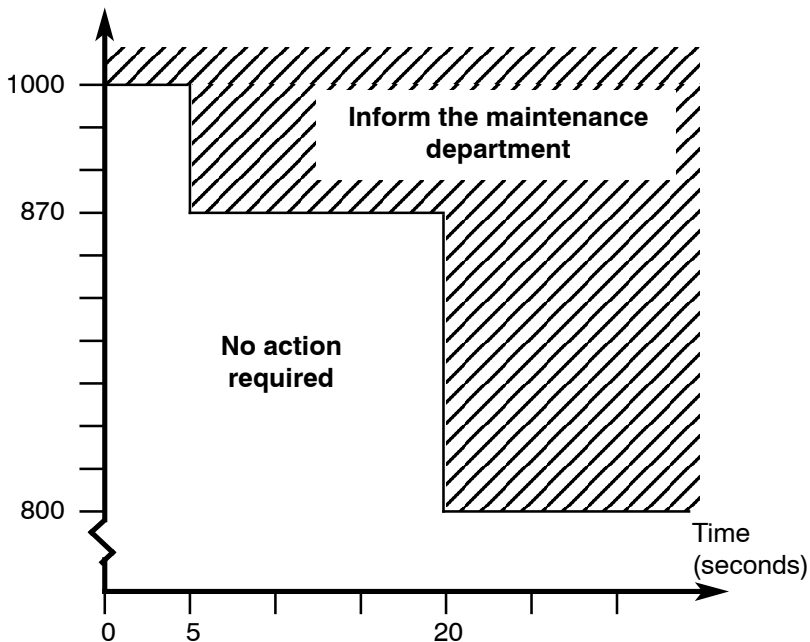

TEMPERATURE LIMITS DURING START

If the above diagram limits are exceeded :

- 1 - ITT indicator **CHECK**
- 2 - Stop the starting procedure.



3.3 - ENGINE FAILURES

RED WARNING LIGHT ITT **ON (2/2)**

- 3 - Record the engine parameters read as well as ground conditions.
- 4 - Inform maintenance department.

During flight

- 1 - ITT indicator **CHECK**
- 2 - Reduce power and correct display according to "Engine Operation" tables - Chapter 5.7

If ITT remains > 800°C :

- 3 - Reduce power to maintain ITT < 800°C.
- 4 - Shorten the flight.
- 5 - Record the airplane and engine parameters read in case of overtemperature.
- 6 - Inform maintenance department at the end of the flight.

3.3 - ENGINE FAILURES

ENGINE DOES NOT STOP ON GROUND

If the engine does not stop when the condition lever is set to CUT OFF, proceed as follows :

- 1 - "AP / TRIMS MASTER" switch **OFF**
- 2 - "RADIO MASTER" switch **OFF**
- 3 - "INT. LIGHTS" panel
All switches **OFF**
- 4 - "EXT. LIGHTS" panel
All switches **OFF**
- 5 - "ECS" panel
All switches **OFF**
- 6 - Tank selector **OFF**
Wait for engine stop due to lack of fuel in the pipes
- 7 - "GENERATOR" selector **MAIN**
- 8 - "SOURCE" selector **OFF**
- 9 - CRASH lever **PULL DOWN**
- 10 - Inform the maintenance department

INTENTIONALLY LEFT BLANK

3.4 - AIR START

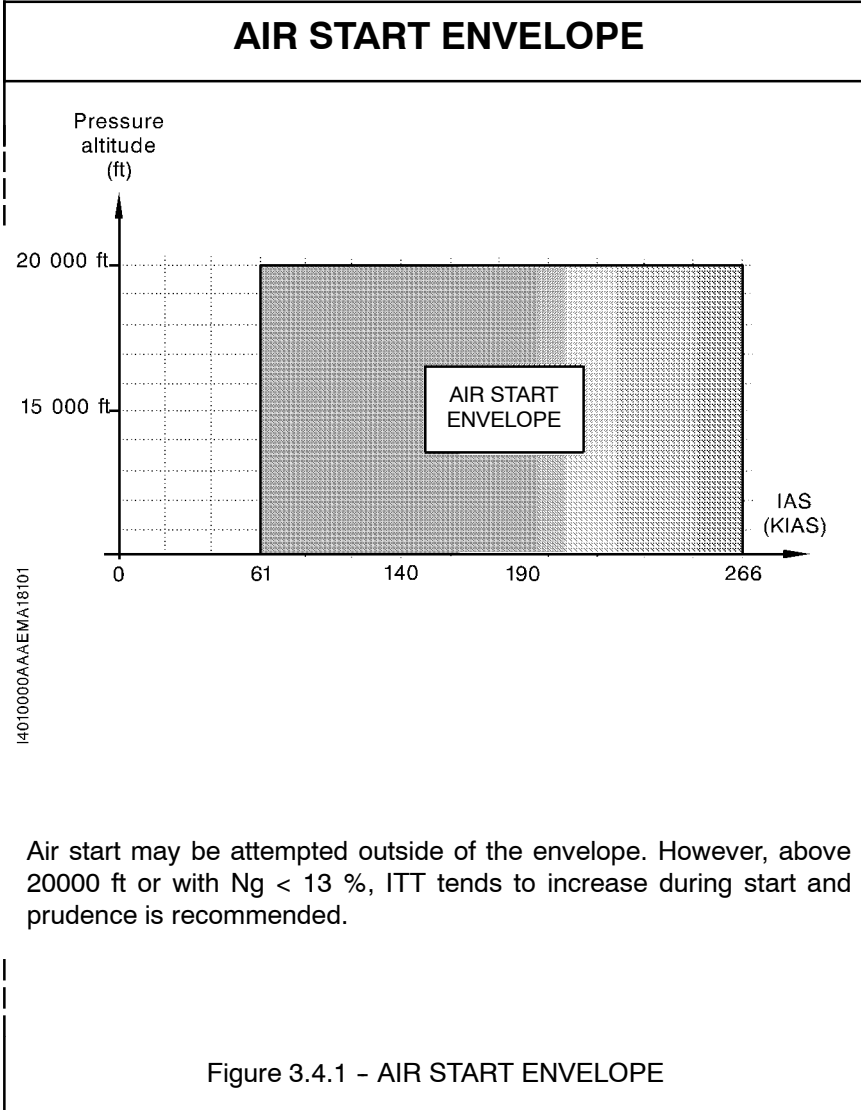

Air start may be attempted outside of the envelope. However, above 20000 ft or with $N_g < 13\%$, ITT tends to increase during start and prudence is recommended.

3.4 – AIR START

AIR START WITH STARTER (1/2)

CAUTION

THE STARTER CANNOT OPERATE IF THE "GENERATOR" SELECTOR IS ON "ST-BY"

CAUTION

IGNITION IS NOT AVAILABLE IF THE "ESS BUS TIE" SWITCH IS KEPT "EMER"

1 - "BLEED" switch **OFF**

CAUTION

"BLEED" SWITCH ON MAY CAUSE OVERTEMPERATURE OR ABNORMAL ACCELERATION

2 - "AIR COND" switch **OFF**

3 - Air start envelope **CHECKED**

4 - Electric consumption **REDUCE**

5 - Power lever **IDLE**

6 - Propeller governor lever **FEATHER**

7 - Condition lever **CUT OFF**

8 - Tank selector **CHECK**

9 - "AUX BP" fuel switch **ON**

10 - "IGNITION" switch **AUTO or ON**

11 - "STARTER" switch **ON**



3.4 – AIR START

AIR START WITH STARTER (2/2)

- 12 – Condition lever **LO / IDLE**
when Ng ~ 13 %
- 13 – ITT and Ng **MONITOR**
- 14 – When Ng ~ 50 % steady **STARTER OFF**
IGNITION AUTO
- 15 – Condition lever **HI / IDLE**
- 16 – Propeller governor lever **MAX. RPM**
- 17 – Power lever **AS REQUIRED**
- 18 – Electrical equipment **AS REQUIRED**
- 19 – "AUX BP" fuel switch **AUTO**
- 20 – "BLEED" switch **AS REQUIRED**

CAUTION

**WITH THE EFS 40, DISPLAYS ARE MOMENTARILY LOST
DURING STARTER OPERATION**

CAUTION

**WITH ALTIMETERS AM250 (if installed), ALTITUDE
INFORMATION IS MOMENTARILY CUT OFF DURING
STARTER OPERATION**

INTENTIONALLY LEFT BLANK

3.5 - FIRE AND SMOKE

ENGINE FIRE ON GROUND

Symptoms : ITT increasing, red warning light ITT on, smoke, ...

- 1 - Power lever **IDLE**
- 2 - Condition lever **CUT OFF**
- 3 - "BLEED" switch **OFF**
- 4 - "AIR COND" switch **OFF**
- 5 - Brakes **AS REQUIRED**
- 6 - Tank selector **OFF**
- 7 - Warn ground assistance, if necessary
- 8 - CRASH lever **PULL DOWN**
- 9 - EVACUATE as soon as possible

CABIN FIRE ON GROUND

- 1 - Power lever **IDLE**
- 2 - Condition lever **CUT OFF**
- 3 - Brakes **AS REQUIRED**
- 4 - Warn ground assistance, if necessary
- 5 - CRASH lever **PULL DOWN**
- 6 - Cabin extinguisher **AS REQUIRED**
- 7 - EVACUATE as soon as possible

3.5 - FIRE AND SMOKE

ENGINE FIRE IN FLIGHT

Symptoms : ITT increasing, red warning light ITT on, smoke, ...

- 1 - Power lever **IDLE**
- 2 - Propeller governor lever **FEATHER**
- 3 - Condition lever **CUT OFF**
- 4 - "AUX BP" fuel switch **OFF**
- 5 - Tank selector **OFF**
- 6 - "BLEED" switch **OFF**
- 7 - "AIR COND" switch **OFF**
- 8 - In case of high altitude (above 12000 ft), undertake an EMERGENCY DESCENT (Refer to Chapter 3.6)
- 9 - Perform a FORCED LANDING (ENGINE CUT OFF) (Refer to Chapter 3.7)

WARNING
AFTER ENGINE FIRE, DO NOT ATTEMPT AN AIR START

3.5 - FIRE AND SMOKE

CABIN ELECTRICAL FIRE OR SMOKE DURING FLIGHT (1/2)

If the origin is known :

- 1 - Oxygen and goggles (if installed) **USE AS REQUIRED (pilot and passengers)**
- 2 - Defective equipment
Corresponding circuit breaker **PULL**
Descend quickly below 12000 ft
- 3 - Using the on board extinguisher, **EXTINGUISH** fire if necessary
- 4 - Smoke elimination
(if necessary) **UNDERTAKE PROCEDURE (Refer to this chapter)**
- 5 - **LAND** as soon as possible

If the origin is unknown :

- 1 - Oxygen and goggles (if installed) **USE AS REQUIRED (pilot and passengers)**
- 2 - "AIR COND" switch **OFF**
- 3 - Non essential equipment **OFF**
- 4 - Smoke elimination
(if necessary) **UNDERTAKE PROCEDURE (Refer to this chapter)**

If smoke or fire stops :

LAND as soon as possible.



3.5 - FIRE AND SMOKE

**CABIN ELECTRICAL FIRE OR
SMOKE DURING FLIGHT (2/2)**

If smoke or fire persists :

- 5 - "SOURCE" selector **OFF**
- 6 - "GENERATOR" selector **OFF**
- 7 - Fire **EXTINGUISH if necessary with the
on board extinguisher**
- 8 - All "pull-off" type circuit-breakers **PULL**
- 9 - All electrical equipment **CUT OFF**
- 10 - "SOURCE" selector **BAT**
- 11 - "GENERATOR" selector **MAIN**
- 12 - Necessary circuit-breakers **ENGAGE
one after the other checking for
possible fire or smoke**
- 13 - Necessary electrical equipment **ON
one after the other checking for
possible fire or smoke**
- 14 - Defective equipment
Corresponding circuit breaker **PULL**
- 15 - Not affected essential equipment **ON as required**
- 16 - LAND as soon as possible

3.5 - FIRE AND SMOKE

SMOKE ELIMINATION

- 1 - Smoke origin **IDENTIFY**
- 2 - Oxygen and goggles (if installed) **USE AS REQUIRED**
(pilot and passengers)
- 3 - If smoke persists, undertake an EMERGENCY DESCENT (Refer to Chapter 3.6)
- 4 - "BLEED" switch **OFF**
- 5 - "AIR COND" switch **OFF**
- 6 - "DUMP" control **ACTUATE**
Wait until the differential pressure drops
- 7 - "RAM AIR" control knob **PULL**
If smoke increases **PUSH**
- 8 - LAND as soon as possible

INTENTIONALLY LEFT BLANK

3.6 - EMERGENCY DESCENTS

Two types of descent are considered :

1 - Engine running, maximum descent rate, if necessary

The factors to be considered are :

- Cabin altitude and oxygen duration
- Electrical power endurance
- Distance to appropriate landing area
- Flight conditions IMC, VMC, ICING
- Minimum safe altitude
- Fuel reserves

2 - Engine failure, aircraft flown for maximum range

The pilot is in charge of evaluating the situation and priorities.

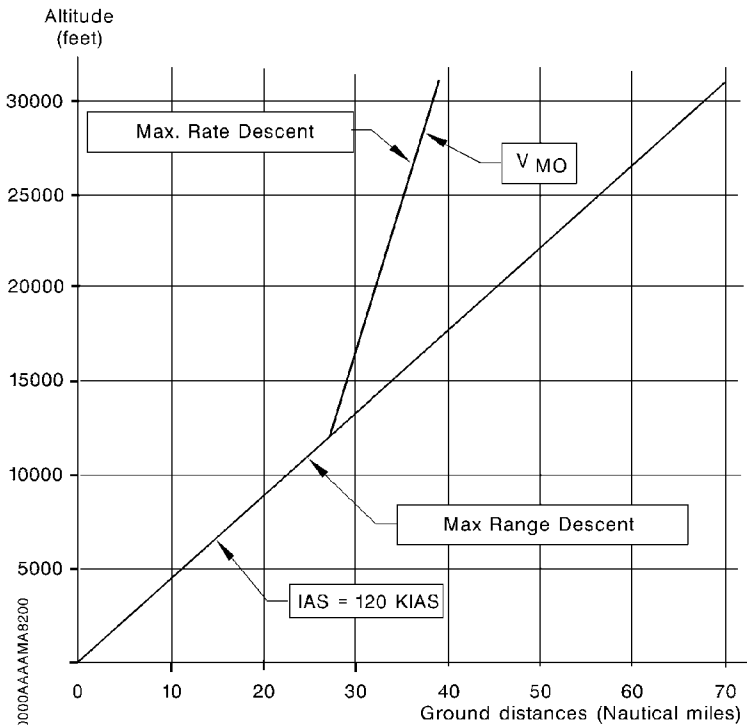

Figure 3.6.1 - EMERGENCY DESCENT PROFILES

3.6 - EMERGENCY DESCENTS

MAXIMUM RATE DESCENT

- 1 - Power lever **IDLE**
- 2 - Oxygen **If necessary**
- 3 - Propeller governor lever **MAX. RPM**

Procedure in smooth air :

- 4 - Flaps **UP**
- 5 - Landing gear **UP**
- 6 - Speed **V_{MO} = 266 KIAS**

Procedure in rough air or in case of structure problem :

- 7 - Reduce speed **IAS ≤ 178 KIAS**
- 8 - Landing gear **DN**
- 9 - Flaps **UP**
- 10 - Keep **IAS ≤ 178 KIAS**

MAXIMUM RANGE DESCENT (1/3)

- 1 - Power lever **IDLE**
- 2 - Propeller governor lever **FEATHER**
- 3 - Condition lever **CUT OFF**
- 4 - Flaps **UP**
- 5 - Landing gear **UP**
- 6 - Speed **IAS = 120 KIAS**



3.6 - EMERGENCY DESCENTS

MAXIMUM RANGE DESCENT (2/3)

7 - Oxygen **If necessary**

Check oxygen duration before reaching 12000 ft and check flow to passengers

8 - "DUMP" switch **ACTUATED**

9 - "RAM AIR" control knob **PULLED**

If conditions allow : VMC and non icing conditions :

10 - "ESS BUS TIE" reverse switch **Cover up
EMER position**

11 - Prepare a forced landing **Refer to Chapter 3.7**

If flight conditions do not allow :

12 - "ESS BUS TIE" reverse switch **NORMAL**

13 - Manually disconnect ancillary systems as follows :

- "AIRFRAME DE ICE" switch **OFF**
- "ICE LIGHT" switch **OFF**
- "PROP DE ICE" switch **OFF**
- "R.WINDSHIELD" switch **OFF**
- "PITOT 2 & STALL HTR" switch **OFF**
- "L.LDG / TAXI / R.LDG / PULSE SYST" switches **OFF**
- "STROBE" switch **OFF**
- "BLEED / AIR COND / FAN FLOW" switches **OFF**
- "AUX BP" switch **OFF**
- "FUEL SEL" switch **MAN**
- "AP/TRIMS MASTER" switch **OFF**
- "EHSI" breaker **PULLED**
- VHF 1 / NAV 1 / GPS 1 **OFF**
- MFD **OFF**
- ADF **OFF**
- Stormscope switch **OFF**



3.6 - EMERGENCY DESCENTS

MAXIMUM RANGE DESCENT (3/3)

- "CD" player **OFF**
- "INSTR / CABIN / ACCESS" controls **OFF**
- "GYRO INST" panel, all switches **OFF**
- Transponder 2 **OFF**

If icing conditions :

- "PITOT 1 HTR" switch **Checked ON**
- "L.WINDSHIELD" switch **ON**
- Maintain minimum recommended speeds (Chapter 4.5 - "Flight into known icing conditions", Paragraph "Ice protection procedures", Point 3)

If time permits :

- "RADIO + FAN" breaker **PULLED**
- "28 VDC PLUGS" breaker **PULLED**
- "AIR COND" breaker **PULLED**

14 - Prepare a forced landing **Refer to Chapter 3.7**

3.7 - EMERGENCY LANDINGS

FORCED LANDING (ENGINE CUT OFF)

(Refer to Supplement 41 for TBM 700C2 airplane)

- 1 - Power lever **IDLE**
- 2 - Propeller governor lever **FEATHER**
- 3 - Condition lever **CUT OFF**
- 4 - Tank selector **OFF**
- 5 - "AUX BP" fuel switch **OFF**
- 6 - "BLEED" switch **OFF**
- 7 - "AIR COND" switch **OFF**
- 8 - "DUMP" switch **ACTUATED**
- 9 - Glide speed **120 KIAS maintained until favourable ground approach**

If ground allows it :

- 10 - "ESS BUS TIE" reverse switch **NORMAL in order to have GEAR and FLAPS available**
- 11 - Landing gear **DN**

If night conditions :

- 12 - L.LDG / R.LDG **ON**

If ground does not allow it :

- 13 - Keep landing gear **UP**
- 14 - When chosen ground is assured **FLAPS LDG**
- 15 - CRASH lever **PULL DOWN**
- 16 - Final approach **IAS = 80 KIAS**
- 17 - Land flaring out
- 18 - EVACUATE after stop

3.7 - EMERGENCY LANDINGS

TIRE BLOWOUT DURING LANDING

- 1 - Control direction with brakes and nose wheel steering
- 2 - REVERSE **AS REQUIRED**
- 3 - Stop airplane to minimize damages
- 4 - Perform engine SHUT-DOWN procedure (Refer to Chapter 4.3)

3.7 - EMERGENCY LANDINGS

LANDING WITH UNLOCKED MAIN LANDING GEAR (1/2)

- 1 - Ask control tower or another airplane to visually check landing gear position

CAUTION
IF ONE MAIN LANDING GEAR IS NOT DOWN, IT IS BETTER TO LAND WITH GEAR UP.

If defective gear is down but unlocked :

- 2 - "BLEED" switch **OFF**
- 3 - "DUMP" switch **ACTUATED**
- 4 - Maintain tank selector on defective landing gear side to lighten corresponding wing [maximum fuel unbalance 25 us gal (95 litres)]
- 5 - Choose a runway with headwind or crosswind blowing from defective gear side
- 6 - Align the airplane to land on the runway edge opposite to the defective landing gear
- 7 - Land and set nose gear immediately on ground to assure lateral control
- 8 - Use full aileron during roll-out to lift the wing with the defective landing gear
- 9 - Preferably do not use reverse
- 10 - Complete taxiing with a slight turn toward defective landing gear



3.7 - EMERGENCY LANDINGS

**LANDING WITH UNLOCKED MAIN
LANDING GEAR (2/2)**

- 11 - Condition lever **CUT OFF**
- 12 - Engine stop procedure **COMPLETE**
- 13 - EVACUATE

If landing gear drags during landing :

- 14 - Condition lever **CUT OFF**
- 15 - CRASH lever **PULL DOWN**
- 16 - Tank selector **OFF**
- 17 - EVACUATE after airplane comes to a stop

3.7 - EMERGENCY LANDINGS

**LANDING WITH DEFECTIVE NOSE LANDING
GEAR (DOWN UNLOCKED OR NOT DOWN)****(Refer to Supplement 41 for TBM 700C2 airplane)**

- 1 - Transfer passengers to the rear, if necessary
- 2 - Approach **Flaps TO
IAS = 90 KIAS**
- 3 - Land with nose-up attitude, keep nose high
- 4 - Condition lever **CUT OFF**
- 5 - Propeller governor lever **FEATHER**
- 6 - Touch-down slowly with nose wheel and keep elevator at nose-up stop
- 7 - Moderate braking
- 8 - CRASH lever **PULL DOWN**
- 9 - EVACUATE after airplane comes to a stop

3.7 - EMERGENCY LANDINGS

LANDING WITH GEAR UP
(Refer to Supplement 41 for TBM 700C2 airplane)

1 - Final approach **Standard**
(Flaps LDG, IAS = 80 KIAS)

2 - "BLEED" switch **OFF**

3 - "DUMP" switch **ACTUATED**

When runway is assured :

4 - Power lever **IDLE**

5 - Propeller governor lever **FEATHER**

6 - Condition lever **CUT OFF**

7 - Tank selector **OFF**

8 - Flare out

9 - After touch-down, CRASH lever **PULL DOWN**

10 - EVACUATE after airplane comes to a stop

3.7 - EMERGENCY LANDINGS

LANDING WITHOUT ELEVATOR CONTROL

- 1 - Configuration **LANDING GEAR DN - FLAPS LDG**
- 2 - Airspeed **Maintain IAS = 95 KIAS**
- 3 - Power as necessary to maintain airspeed according to an easy approach slope \simeq 300 ft / min
- 4 - Adjust elevator by using manual pitch trim wheel
- 5 - When ground approaches, decrease slope progressively
- 6 - Reduce power progressively

3.7 - EMERGENCY LANDINGS

LANDING WITH FLAPS MALFUNCTION
(Refer to Supplement 41 for TBM 700C2 airplane)

For flaps deflections from "UP" to "TO" position :

Proceed as for a normal landing, maintaining approach airspeed :

- Weight \leq 6250 lbs (2835 kg) **IAS = 100 KIAS**

Provide for a landing distance increased up to about 60 %

For flaps deflections greater than "TO" position :

Proceed as for a normal landing, maintaining approach airspeed :

- Weight \leq 6250 lbs (2835 kg) **IAS = 95 KIAS**

Provide for a landing distance increased up to about 50 %

3.7 - EMERGENCY LANDINGS

DITCHING

(Refer to Supplement 41 for TBM 700C2 airplane)

- 1 - Landing gear **UP**
In heavy swell with light wind, land parallel to the swell (rollers).
In heavy wind, land facing wind.
- 2 - Flaps **LDG**
- 3 - Maintain a descent rate as low as possible when approaching the water
- 4 - Airspeed **IAS = 80 KIAS**
- 5 - "BLEED" switch **OFF**
- 6 - "DUMP" switch **ACTUATED**
- 7 - CRASH lever **PULL DOWN**
- 8 - Maintain attitude without rounding off until touch-down
- 9 - EVACUATE through EMERGENCY EXIT

INTENTIONALLY LEFT BLANK

3.8 - FUEL SYSTEM

RED WARNING LIGHT **FUEL PRESS** **ON (1/2)**

Indicates a fuel pressure drop at "HP" engine pump inlet

- 1 - Remaining fuel **CHECK**
- 2 - Tank selector **SWITCH TANKS**
- 3 - Fuel pressure indication **CHECK**
- 4 - "AUX BP" fuel switch **AUTO
CHECK / CORRECT**

If alarm persists :

- 5 - "AUX BP" fuel switch **ON**
Warning light **AUX BP ON** on **CHECK**
- 6 - Fuel pressure **CHECK**

If pressure is normal again and warning light is off, mechanical pump has failed.

- 7 - Maintain "AUX BP" fuel switch **ON**

If pressure remains at 0 (or drops to 0 after "AUX BP" pump operation)

*and if warning **FUEL PRESS** remains on :*

- 8 - Tank switching **PERFORM**

If pressure is normal again, a supply problem may have occurred from the tank selected first (air vent, fuel icing, etc ...).



3.8 - FUEL SYSTEM

RED WARNING LIGHT **FUEL PRESS** **ON (2/2)**

*If pressure remains at 0 and if warning **FUEL PRESS** remains on :*

9 - Selection of the fullest tank **PERFORM**

10 - Avoid high power and rapid movements of the power lever.

11 - Descend to an altitude below 20000 ft.

12 - Land as soon as possible.

3.8 - FUEL SYSTEM

AMBER WARNING LIGHT

AUX BP ON

ON

(Indication is normal if "AUX BP" fuel switch is in ON position)

If "AUX BP" fuel switch is in AUTO position :

- 1 - Reset to **ON**
- 2 - Then to **AUTO**

*If **AUX BP ON** warning light goes out, continue flight normally*

*If **AUX BP ON** warning light remains on, mechanical booster pump has failed*

In that case :

- 3 - "AUX BP" fuel switch **ON**
- 4 - Shorten flight

3.8 - FUEL SYSTEM

AMBER WARNING LIGHT

FUEL L. LO

OR

FUEL R. LO

ON

Indicates level drop in the corresponding tank

- 1 - Corresponding gage **CHECK**
- 2 - Check the other tank has been automatically selected
If not :
- 3 - "FUEL SEL" switch **MAN**
- 4 - Select tanks manually as required

AMBER WARNING LIGHT

AUTO SEL

ON

Indicates that the mode control automatic timer is off or has failed

- 1 - "FUEL SEL" switch **AUTO
CHECK / CORRECT**
- 2 - If it is on AUTO : confirmed failure
- 3 - "FUEL SEL" switch **MAN**
- 4 - Select tanks manually as required

3.9 - ELECTRICAL SYSTEM

RED WARNING LIGHT BAT OVHT ON (if Cadmium-Nickel battery installed)
<p>Indicates a battery overheat</p> <p>1 - "SOURCE" selector OFF</p> <div style="text-align: center; margin: 10px 0;"> WARNING LIGHT BAT OVHT ON </div> <p>2 - Monitor airplane mains battery voltage</p> <p>3 - LAND AS SOON AS POSSIBLE</p> <p><i>REMARK :</i> <i>In case of subsequent electrical generator failure, the battery can be used again by selecting :</i></p> <p>4 - "GENERATOR" selector OFF</p> <div style="text-align: center; margin: 10px 0;"> WARNING LIGHT MAIN GEN ON </div> <p>5 - "SOURCE" selector BAT</p> <p>6 - Refer to paragraph "AMBER WARNING LIGHT "LO VOLT" ON functioning on "ST-BY GENERATOR" (after "MAIN GEN" failure)"</p>

AMBER WARNING LIGHT BAT OFF ON
<p>Indicates that "SOURCE" selector has been positioned on OFF or GPU, or that the battery is disconnected from the mains</p> <p>1 - If necessary CORRECT</p> <p>2 - If warning persists SHORTEN FLIGHT</p> <p>3 - Monitor airplane mains voltage</p>

3.9 - ELECTRICAL SYSTEM

AMBER WARNING LIGHT **MAIN GEN** **ON**

Indicates that "GENERATOR" selector has been positioned to OFF or ST-BY, or main generator is cut off

1 - If necessary **CORRECT**

2 - If warning persists **"MAIN GEN" switching confirmed**

3 - "MAIN GENERATOR RESET" push-button **PUSH**

In case of failure :

4 - Disconnect following ancillary electrical systems :

- "AIR COND" switch **OFF**

- "STROBE" switch **OFF**

- "NAV" switch **OFF**

- "CABIN" lights switch **OFF**

- "AP/TRIMS MASTER" switch **AP OFF**

- All equipment not essential **OFF**

- "L.WINDSHIELD" switch
(above 15 000 ft) **OFF**

- "R.WINDSHIELD" switch
(above 15 000 ft) **OFF**

- "BLEED" switch
(before landing and on ground) **OFF**

- Only use landing lights briefly and if necessary.

5 - "GENERATOR" selector **ST- BY**
(RESET if necessary)

3.9 - ELECTRICAL SYSTEM

AMBER WARNING LIGHT LO VOLT ON normal functioning on "MAIN GEN"

1 - Voltmeter voltage **CHECK**

2 - If voltage is < 26 Volts, monitor a possible drop or any indication of battery run-down

In that case :

3 - Disconnect following ancillary electrical systems :

- "AIR COND" switch **OFF**
- "STROBE" switch **OFF**
- "NAV" switch **OFF**
- "CABIN" lights switch **OFF**
- "AP / TRIMS MASTER" switch **AP OFF**
- All equipment not essential **OFF**
- "L.WINDSHIELD" switch
(above 15 000 ft) **OFF**
- "R.WINDSHIELD" switch
(above 15 000 ft) **OFF**
- "BLEED" switch
(before landing and on ground) **OFF**
- Only use landing lights briefly and if necessary.

4 - "GENERATOR" selector **ST-BY**
(RESET if necessary)

5 - Voltage and battery charge **MONITOR**

3.9 - ELECTRICAL SYSTEM

AMBER WARNING LIGHT LO VOLT ON
functioning on "ST-BY GENERATOR"
(after "MAIN GEN" failure) (1/3)

Amber warning lights MAIN GEN and LO VOLT ON
with "GENERATOR" selector on "ST-BY"

- 1 - "GENERATOR" selector **MAIN**
- 2 - "MAIN GENERATOR RESET" push-button **PRESS**

If successful :

- 3 - Disconnect ancillary electrical systems not essential
- 4 - Monitor voltmeter and ammeter

Prepare to SHORTEN FLIGHT

If not successful :

- 5 - "GENERATOR" selector **ST-BY**
- 6 - "ST-BY GENERATOR RESET" push-button **PRESS**

If successful :

- 7 - Disconnect ancillary electrical systems not essential
- 8 - Monitor voltmeter and ammeter

Prepare to SHORTEN FLIGHT

If not successful, both generators failure is confirmed. If possible, return to VMC conditions



3.9 - ELECTRICAL SYSTEM

AMBER WARNING LIGHT LO VOLT ON
functioning on "ST-BY GENERATOR"
(after "MAIN GEN" failure) (2/3)

9 - "GENERATOR" selector **OFF**

If conditions allow : VMC and non icing conditions

10 - If altitude ≥ 12000 ft : "OXYGEN" switch **ON**

11 - "ESS BUS TIE" reverse switch **Cover up
EMER position**

In this configuration, only both "ESS BUS" bars and "BUS BAT" bar are directly supplied by the battery

Available ancillary systems - see Figure 3.9.1

12 - LAND as soon as possible

If necessary, it is always possible to use other ancillary systems by selecting :

- "ESS BUS TIE" reverse switch **NORMAL**

If flight conditions do not allow :

13 - Manually disconnect ancillary systems as follows :

- "AIRFRAME DE ICE" switch **OFF**
- "ICE LIGHT" switch **OFF**
- "PROP DE ICE" switch **OFF**
- "R.WINDSHIELD" switch **OFF**
- "PITOT 2 & STALL HTR" switch **OFF**
- "L.LDG / TAXI / R.LDG / PULSE SYST" switches **OFF**
- "STROBE" switch **OFF**
- "BLEED / AIR COND / FAN FLOW" switches **OFF**
- "AUX BP" switch **OFF**
- "FUEL SEL" switch **MAN**
- "AP/TRIMS MASTER" switch **OFF**
- "EHSI" breaker **PULLED**



3.9 - ELECTRICAL SYSTEM

AMBER WARNING LIGHT LO VOLT **ON**
functioning on "ST-BY GENERATOR"
(after "MAIN GEN" failure) (3/3)

- VHF 1 / NAV 1 / GPS 1 **OFF**
- MFD **OFF**
- ADF **OFF**
- Stormscope switch **OFF**
- "CD" player **OFF**
- "INSTR / CABIN / ACCESS" controls **OFF**
- "GYRO INST" panel, all switches **OFF**
- Transponder 2 **OFF**

If icing conditions :

- "PITOT 1 HTR" switch **Checked ON**
- "L.WINDSHIELD" switch **ON**
- Maintain minimum recommended speeds (Chapter 4.5 - "Flight into known icing conditions", Paragraph "Ice protection procedures", Point 3)

If time permits :

- "RADIO + FAN" breaker **PULLED**
- "28 VDC PLUGS" breaker **PULLED**
- "AIR COND" breaker **PULLED**

14 - LAND as soon as possible

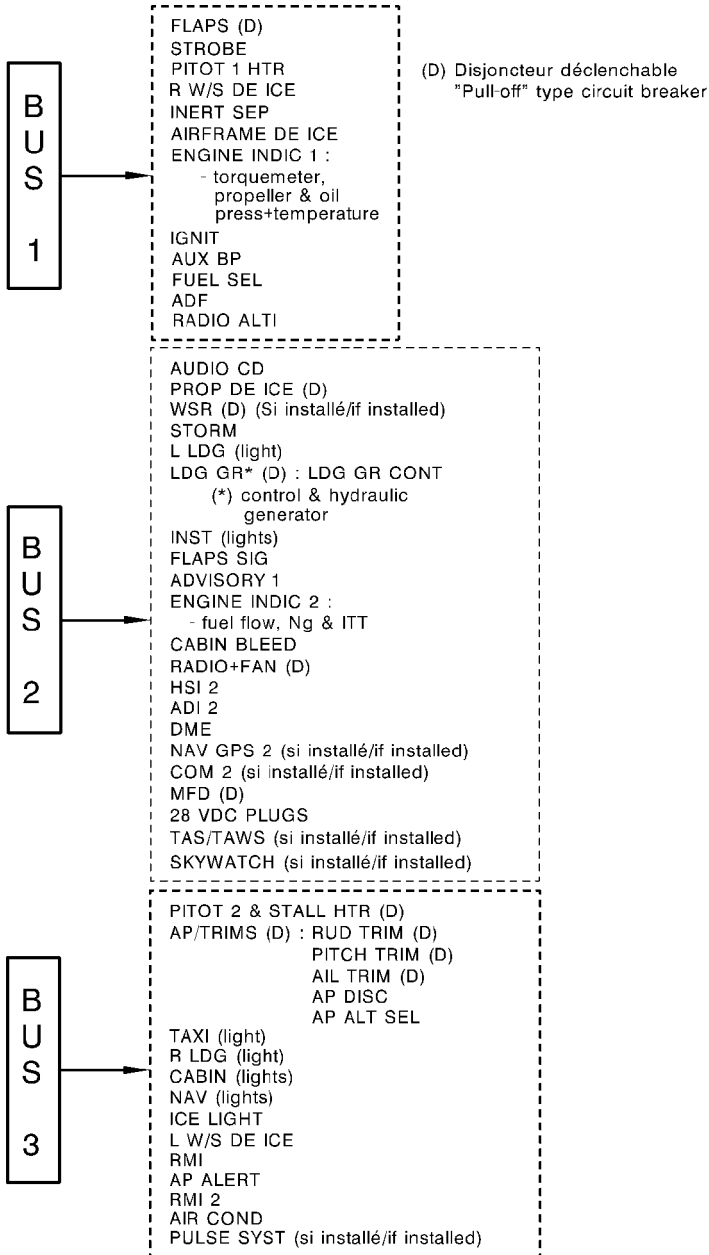

14246000AAACMA8200

Figure 3.9.1 (1/2) - ELECTRICAL DISTRIBUTION OF BUS BARS

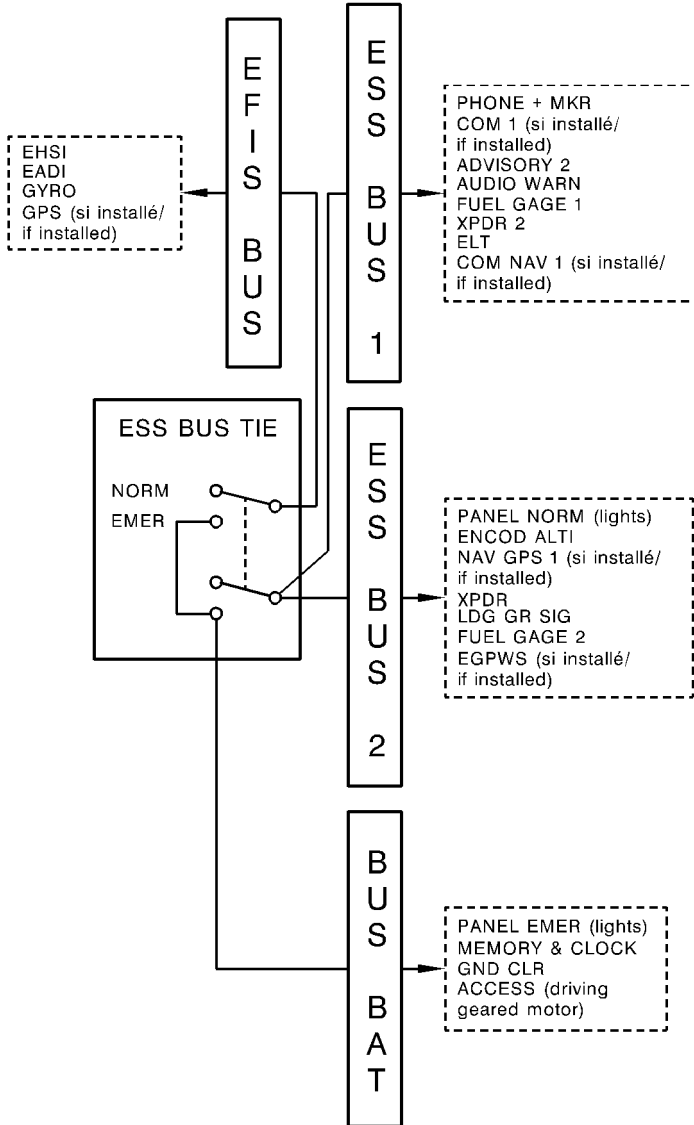

14246000AAACMA8100

Figure 3.9.1 (2/2) - ELECTRICAL DISTRIBUTION OF BUS BARS

3.9 - ELECTRICAL SYSTEM

"RADIO MASTER" SWITCH FAILURE

In case of "RADIO MASTER" switch malfunction, leading to the impossibility of energizing the radionavigation equipment :

- 1 - "RADIO FAN" circuit breaker **PULL**
[Circuit breaker panel L.H. (or R.H., if "pilot" door installed) lower corner]

The radionavigation equipment are supplied again and the flight can continue.

However the equipment forced ventilation is no longer available. An excessive use of VHF COM transmitters may reduce their power, so that transmission range will be limited.

INTENTIONALLY LEFT BLANK

3.10 - PRESSURIZATION AND AIR CONDITIONING

RED WARNING LIGHT CAB PRESS ON

1 - Pressurization indicator **CHECK**

If $\Delta P > 6.2$ psi :

2 - "BLEED" switch **OFF**

3 - EMERGENCY DESCENT (Refer to Chapter 3.6)

If cabin altitude > 10000 ft :

4 - Oxygen **Refer to Chapter 3.13**

5 - "BLEED" switch **CHECK ON**

6 - "DUMP" switch **CHECK UNDER GUARD**

7 - "RAM AIR" control knob **CHECK PUSHED**

8 - Limit flight altitude to maintain cabin altitude < 12000 ft

9 - If necessary EMERGENCY DESCENT (Refer to Chapter 3.6)

CABIN NOT DEPRESSURIZED AFTER LANDING

ΔP cabin > 0

1 - "DUMP" switch **ACTUATED**

2 - "BLEED" switch **OFF**

3 - "RAM AIR" control knob **PULLED if necessary**

4 - Wait for complete cabin depressurization before opening the door

3.10 - PRESSURIZATION AND AIR CONDITIONING

AMBER WARNING LIGHT **BLEED OFF** **ON**

Indicates an overpressure at air conditioning pack inlet or a malfunction of the pressure stop and regulating valve

(Normal signal if "BLEED" switch is OFF)

1 - If necessary **CORRECT**

2 - If possible, reduce power

3 - "BLEED" switch **OFF**

4 - "BLEED" switch **ON**

5 - If **BLEED OFF** ON, and if necessary EMERGENCY DESCENT
(refer to Chapter 3.6) or continue flight at an altitude < 12000 ft)

6 - Continue flight

3.10 - PRESSURIZATION AND AIR CONDITIONING

RED WARNING LIGHT BLEED TEMP ON

Indicates overheat of air conditioning pack. Normally this leads to BLEED cutoff and to BLEED OFF amber warning light illumination.

Should automatic cutoff occur or not :

- 1 - If possible, reduce power
- 2 - "AIR FLOW" distributor **CABIN**
- 3 - "CABIN TEMP/° C" selector **15° C**
- 4 - "BLEED" switch **OFF**
- 5 - As soon as BLEED TEMP OFF, "BLEED" switch **ON**

If BLEED TEMP and BLEED OFF still ON :

- 6 - If necessary EMERGENCY DESCENT (Refer to Chapter 3.6) or continue flight at an altitude < 12000 ft
- 7 - Continue flight

3.10 - PRESSURIZATION AND AIR CONDITIONING

RED WARNING LIGHT **DOOR** **ON**

Indicates that one of the door latches of the access door and (if installed) of the "pilot" door has not been correctly locked

***On ground**, check the correct locking, as well as the latches position of the access door and (if installed) of the "pilot" door*

During flight :

- 1 - Start a slow descent
- 2 - Decrease cabin ΔP by selecting a higher cabin altitude and maximum cabin rate

If real failure of one of the doors is noted :

- 3 - "BLEED" switch **OFF**
- 4 - "DUMP" switch **ACTUATED**
- 5 - If necessary, undertake an EMERGENCY DESCENT of "IN ROUGH ATMOSPHERE" type (Refer to Chapter 3.6)

3.10 - PRESSURIZATION AND AIR CONDITIONING

AMBER WARNING LIGHT VACUUM LO **ON**

Suction gage indicator **CHECK**

Low vacuum may lead to malfunctioning of leading edge
deicing, pressurization and gyroscopic vacuum-operated
instruments **MONITOR**

If necessary, fly to an altitude \leq 12000 ft and if possible return to VMC
conditions

“BLEED” switch **OFF**

3.10 – PRESSURIZATION AND AIR CONDITIONING

DEFOG MALFUNCTION

If moisture starts to quickly cover the inside of the windscreen with the distributor already positioned on "DEFOG" :

- 1 - "AIR FLOW" distributor **Set to around
a 10 o'clock position**

If moisture continues :

- 2 - "AIR FLOW" distributor **HOT**
3 - "L. WINDSHIELD" switch **ON**
4 - "R. WINDSHIELD" switch **ON**

If there is no improvement and if the flight safety is engaged :

- 5 - Altitude **≤12000 ft**
6 - "BLEED" switch **OFF**

NOTE :

If in flight, the cabin will quickly be depressurized. Therefore, the cabin vertical speed indicator and altimeter indications will rapidly meet those of respectively the aircraft VSI and altimeter.

3.11 - LANDING GEAR AND FLAPS

LANDING GEAR RETRACTION DISCREPANCY

NOTE :

Symptoms have to be considered at the end of the sequence.

A - Symptoms :

Steady red warning light ON **and** 0 to 3 green light(s) ON.

- Actions :

Refer to "EMERGENCY GEAR EXTENSION".

B - Symptoms :

Red warning light flashing **and** 3 green lights OFF.

- Actions :

1 - "LDG GR" circuit breaker **PULL**

If the red warning light goes off :

The flight may be continued without any restriction. The electrohydraulic pump starting will be manually controlled with the "LDG GR" circuit breaker for the landing gear extension.

If the red warning light becomes steady ON :

"LDG GR" circuit breaker **PUSH**

Refer to "EMERGENCY GEAR EXTENSION".

3.11 - LANDING GEAR AND FLAPS

LANDING GEAR EXTENSION DISCREPANCY

NOTE :

Symptoms have to be considered at the end of the sequence.

- Symptoms

Steady red warning light ON **and** 0 to 3 green light(s) OFF.

or

Red warning light flashing **and** 0 to 3 green light(s) OFF.

- Actions

Refer to "EMERGENCY GEAR EXTENSION".

3.11 – LANDING GEAR AND FLAPS

EMERGENCY GEAR EXTENSION (1/2)

NOTE :

This procedure has to be followed in case of any discrepancy or doubt about the gear extension or retraction.

Maintain IAS ≤ 128 KIAS

- 1 - Landing gear control **DN**
- 2 - "LDG GR" circuit breaker **PULL**
- 3 - Floor hatch **OPEN**
- 4 - By-pass selector **FULLY PULL / LOCKED**

CAUTION

THE ENTIRE EXTENSION OF THE LANDING GEAR MAY TAKE UP TO 110 CYCLES. IT IS MANDATORY TO HAVE A CLEAR HARDENING OF THE MANUAL CONTROL AT THE END OF THE MANEUVER

- 5 - Hand pump **ACTUATE with maximum amplitude**

If landing gear is down and locked (red light not illuminated, three green lights illuminated) :

Continue flight if necessary at a speed BELOW 178 KIAS, exit and/or remain outside icing conditions.

Land.

CAUTION

DO NOT ENTER ICING CONDITIONS (THIS COULD ADVERSELY INCREASE DRAG AND WEIGHT DUE TO ICE ACCUMULATION, AND LOCK WHEELS AND STRUTS). CLIMB PERFORMANCE WILL BE DEGRADED BY 50 %. INDICATED CRUISE AIRSPEED WILL BE REDUCED COMPARED TO A CLEAN AIRCRAFT, BECAUSE OF THE DRAG. THIS SHOULD BE TAKEN INTO ACCOUNT WHEN CALCULATING THE AIRCRAFT RANGE.



3.11 - LANDING GEAR AND FLAPS

EMERGENCY GEAR EXTENSION (2/2)

If landing gear does not lock (other than 3 green indicator lights illuminated) :

- 6 - "LDG GR" circuit breaker **PUSH**
- 7 - "CHECK DN" switch **ACTUATE**

If the hardening of the manual lever is marked and if the normal indicating shows 3 green indicator lights or the "CHECK DN" indicating shows 3 green indicator lights :

- 8 - LAND.

If manual extension bar remains soft or if one (or more) green indicator light(s) does(do) not illuminate and upon pressing "CHECK DN", then a gear unlock condition is confirmed. Recycle the landing gear as follows :

- 9 - By-pass selector **UNLOCK / PUSH**
- 10 - Wait a minute.
- 11 - Landing gear control (IAS \leq 128 KIAS) **UP**

Perform landing gear extension attempts in the NORMAL mode while applying positive load factors during the maneuver as well as skidding.

In case of failure, refer to Chapter 3.7 "EMERGENCY LANDINGS", Paragraph "LANDING WITH UNLOCKED MAIN LANDING GEAR" or Paragraph "LANDING WITH DEFECTIVE NOSE LANDING GEAR".

Indication :

If one main landing gear leg is not in the down position, it is preferable to land with landing gear up (Refer to Chapter 3.7, Paragraph "LANDING WITH GEAR UP").

3.11 – LANDING GEAR AND FLAPS

RED WARNING LIGHT FLAPS **ON**

Indicates a dissymmetry of flap deflection. This immediately stops the flap motor and prevents further operation of the flaps

- 1 - "FLAPS" circuit breaker **PULL**
- 2 - Flap control lever **UP**
- 3 - SHORTEN flight maintaining airspeeds :
 - *IAS ≤ 178 KIAS for deflections between "UP" and "TO" positions*
 - *IAS ≤ 122 KIAS for deflections greater than "TO" position*
- 4 - For landing, refer to Chapter 3.7, Paragraph "LANDING WITH FLAPS MALFUNCTION".

FLAPS MALFUNCTION

In case of blockage of flaps or inoperant flap control lever between "UP" and "TO" positions, with no flaps warning light illumination :

- 1 - "FLAPS" circuit breaker **PULL**
- 2 - Flap control lever **UP**
- 3 - SHORTEN flight maintaining airspeeds :
 - *IAS ≤ 178 KIAS for deflections between "UP" and "TO" positions*
 - *IAS ≤ 122 KIAS for deflections greater than "TO" position*
- 4 - For landing, refer to Chapter 3.7, Paragraph "LANDING WITH FLAPS MALFUNCTION".

INTENTIONALLY LEFT BLANK

3.12 - DEICING SYSTEM

LEADING EDGES DEICING FAILURE

Symptoms : Failure on one of the two pneumatic deicing pulses :

- Ice on wing outboard sections
- Or ice on wing inboard sections and stabilizers
- One of the two cycling green lights is not lit

1 - LEAVE icing conditions as soon as possible

2 - "AIRFRAME DE ICE" switch **OFF**

PROPELLER DEICING FAILURE

Symptoms : - Propeller deicing green light is not lit
- Propeller vibrations

1 - REDUCE power

2 - ACTUATE propeller governor lever to vary RPM within operating range

3 - LEAVE icing conditions as soon as possible

3.12 - DEICING SYSTEM

INERTIAL SEPARATOR FAILURE

- Symptoms : - Warning light is not lit within 30 seconds following "INERT SEP" switch setting ON
- Neither torque drop, nor increase of ITT observed during maneuver

LEAVE icing conditions as soon as possible

WINDSHIELD DEICING FAILURE

- Symptoms : - Windshield being covered uniformly by ice
- No perception of heat when touching deiced section
 - Windshield deicing green light is not lit

Symptoms may result from overheat. In that case :

- 1 - "L.WINDSHIELD" switch **OFF / ON**
when necessary
- 2 - "R.WINDSHIELD" switch **OFF / ON**
when necessary

In case of total failure :

- 1 - "CABIN TEMP/°C" selector **Maxi warm**
- 2 - "AIR FLOW" distributor **HOT**

Before landing wait for a sufficient visibility

3.12 - DEICING SYSTEM

WINDSHIELD MISTING OR INTERNAL ICING**(Refer to Supplement 41 for TBM 700C2 airplane)**

Symptoms : - Mist or ice on windshield internal face

- 1 - "CABIN TEMP/° C" selector **Set to 21° C
(12 o'clock position)**
- 2 - "AIR FLOW" distributor **Set to 10 o'clock position**
- 3 - "L. WINDSHIELD" switch **ON**
- 4 - "R. WINDSHIELD" switch **ON**

If not successful, to gain sufficient visibility :

- 5 - "AIR FLOW" distributor **HOT**
- 6 - Manually clean a sufficient visibility area
- 7 - If necessary, clean L.H. side window and conduct a sideslip approach (rudder pedals to the right) in order to get sufficient landing visual references
- 8 - Maintain IAS \geq 90 KIAS

CAUTION**IN CASE OF SIDESLIP APPROACH WITH PEDAL ON THE RIGHT
DURING A LONG PERIOD, SELECT R.H. FUEL TANK**

3.12 - DEICING SYSTEM

AMBER WARNING LIGHT

PITOT 1

PITOT 2

OR

STALL HTR

ON

Indicates a heating failure of the corresponding probe

PITOT 1

Icing conditions may alter airspeed indications on the airspeed indicator

1 - AVOID icing conditions

If it is not possible :

2 - Perform moderate descent or climb attitudes

V_{MO} overshooting and stall warning lights are always operating

PITOT 2

V_{MO} overshoot warning may be altered by icing conditions

Monitor maximum airspeed ≤ 266 KIAS

STALL HTR

Correct operation of the aural stall warning may be altered by severe or prolonged icing

MONITOR and MAINTAIN minimum airspeed according to airplane configuration and icing conditions

3.13 - MISCELLANEOUS

RUNAWAY OF ONE OF THE THREE ELECTRICAL TRIM TABS

- 1 - "AP / DISC TRM INT" push button **PRESSED AND HOLD**

The three trim tabs are disconnected and runaway stops

- 2 - "AP / TRIMS MASTER" switch **OFF**

- 3 - "AP / DISC TRM INT" push button **RELEASED**

- 4 - Pitch trim may be used manually

- 5 - Reduce airspeed if necessary to reduce control forces

If pitch trim runaway

- 6 - "AP / TRIMS MASTER" switch **AP OFF**

The pitch trim may be used manually, the two other trim tabs may be used again electrically

If rudder or aileron trim runaway

- 7 - PULL circuit breaker corresponding to the defective trim tab

- 8 - "AP / TRIMS MASTER" switch **ON**

Two other trim tabs may be used again electrically

CRACK IN COCKPIT WINDOW OR WINDOW PANEL

- 1 - Descend slowly

- 2 - Reduce cabin ΔP by selecting a higher cabin altitude and the maximum cabin rate

3.13 - MISCELLANEOUS

EMERGENCY EXIT USE

- 1 - Check that the anti-theft safety pin has been removed
- 2 - Lift up the opening handle
- 3 - Pull emergency exit assembly toward oneself to release it from its recess
- 4 - Put the emergency exit door inside fuselage or throw it away from the fuselage through the opening
- 5 - EVACUATE airplane

EMERGENCY BEACON USE (ELT)

Before a forced landing :

- 1 - On COM VHF 121.5 MHZ or on a known air traffic control frequency, transmit the "MAY DAY" signal if possible

After landing :

- 2 - "ELT" remote control switch **ON**
(maintain it ON until aid arrives)

3.13 - MISCELLANEOUS

TOTAL COMMUNICATION FAILURE

- 1 - Refer to PARTICULAR TRANSPONDER USES procedures
- 2 - Apply air traffic control procedures in case of communications failure :
 - code 7700 during 1 minute, then
 - code 7600
- 3 - Try to restore communications by using all possible combinations of the headset, micro and loudspeaker

MAIN GYRO HEADING FAILURE

Use standby compass

CAUTION

"L. WINDSHIELD" AND "R. WINDSHIELD" SWITCHES, AS WELL AS AIR CONDITIONING SYSTEM MUST BE SET TO "OFF" BEFORE COMPASS READING

3.13 - MISCELLANEOUS

PARTICULAR TRANSPONDER USES

- 1 - Check transponder mode selector **ON or ALT**
- 2 - Codes selector : 7700 EMERGENCY DISTRESS
 7600 COMMUNICATIONS FAILURE
 7500 HIJACKING

ACCIDENTAL SPINS

(Voluntary spins are prohibited)

In case of accidental spins

- 1 - Control wheel **NEUTRAL : PITCH AND ROLL**
- 2 - Rudder **FULLY OPPOSED TO THE SPIN**
- 3 - Power lever **IDLE**
- 4 - Flaps **UP**
when rotation is stopped
- 5 - Level the wings and ease out of the dive

3.13 - MISCELLANEOUS

OXYGEN USE (1/2)

WARNING

**SMOKING IS STRICTLY PROHIBITED ANY TIME OXYGEN SYSTEM IS USED.
BEFORE USING OXYGEN, REMOVE ANY TRACE OF OIL, GREASE, SOAP AND OTHER FATTY SUBSTANCES (INCLUDING LIPSTICK, MAKE UP, ETC...)**

Front seats

- 1 - Take a mask on the opposite seat side (pilot : R.H. side ; R.H. front passenger : L.H. side) : draw it out of the stowage cup and uncoil tube totally. Press on the red side vanes to inflate the harness. Put the mask on the face.
- 2 - No smokes :
3-position selector **NORMAL**
(100 % as required)
- 3 - In case of smokes :
3-position selector **EMERGENCY**
Don the smoke goggles onto the face
- 4 - "PASSENGERS OXYGEN" switch **ON**
- 5 - Check the oxygen flow indicator for the front seats (the blinker is transparent) and for the rear passengers (the blinker is green).
- 6 - "NORMAL/MASK" micro inverter **MASK**
- 7 - Audio selector selection mode **PILOT or ISO**
- 8 - Perform an emergency descent to the "En route" minimum altitude and, if possible, below 10000 ft.



3.13 - MISCELLANEOUS

OXYGEN USE (2/2)

Passengers

- 1 - Take a mask.
- 2 - Uncoil tube totally.
- 3 - Pull on the lanyard cord to take out the lanyard pin.
- 4 - Put the mask on the face.

3.13 - MISCELLANEOUS

AIRSPEED INDICATING SYSTEM FAILURE

Symptoms : erroneous indication in flight

- 1 - "PITOT 1 HTR" switch **CHECK ON**
- 2 - "PITOT 2 & STALL HTR" switch **CHECK ON**

If symptoms persist :

- 3 - "ALTERNATE STATIC" selector **PULL THOROUGHLY**

If symptoms persist, as well as on the airspeed indicator of the R.H instrument panel, carry out a precautionary approach maintaining an adequate speed.

3.13 - MISCELLANEOUS

FLIGHT INTO SEVERE ICING CONDITIONS

Severe icing conditions, particularly freezing rain and freezing drizzle, can be identified by :

- unusually extensive ice accumulation on the airframe and windshield in areas not normally observed to collect ice,
- accumulation of ice on the upper surface of the wing aft of the protected area.

Procedures for exiting freezing rain or freezing drizzle conditions :

- 1 - Inform Air Traffic Control to exit severe icing conditions by changing the route or the altitude.
- 2 - Avoid any sudden maneuver on flight controls.
- 3 - Do not engage the autopilot.
- 4 - If the autopilot is engaged, hold the control wheel firmly and disengage the autopilot.
- 5 - If an unusual roll response or uncommanded roll control movement is observed, reduce the angle-of-attack.
- 6 - Do not extend flaps when holding in icing conditions. Operation with flaps extended can result in a reduced wing angle-of-attack, with the possibility of ice forming on the upper surface further aft on the wing than normal, possibly aft of the protected area.
- 7 - If the flaps are extended, do not retract them until the airframe is clear of ice.

SECTION 4

NORMAL PROCEDURES

TABLE OF CONTENTS

	Page
4.1 GENERAL	4.1.1
4.2 AIRSPEEDS FOR NORMAL OPERATION	4.2.1
4.3 CHECK-LIST PROCEDURES	4.3.1
PREFLIGHT INSPECTION	4.3.1
BEFORE STARTING ENGINE	4.3.13
STARTING ENGINE USING AIRPLANE POWER	4.3.16
STARTING ENGINE USING EXTERNAL POWER (GPU)	4.3.21
MOTORING	4.3.26
MOTORING FOLLOWED BY AN ENGINE START	4.3.28
AFTER STARTING ENGINE	4.3.30
IN-FLIGHT AVAILABLE OXYGEN QUANTITY	4.3.32
TAXIING	4.3.33
BEFORE TAKEOFF	4.3.34
TAKEOFF	4.3.36
CLIMB	4.3.38
CRUISE	4.3.39
DESCENT	4.3.40
BEFORE LANDING	4.3.41
LANDING	4.3.42
GO-AROUND	4.3.43
TOUCH AND GO	4.3.44
AFTER LANDING	4.3.44
SHUT-DOWN	4.3.45
4.4 AMPLIFIED PROCEDURES	4.4.1
PREFLIGHT INSPECTION	4.4.1
BEFORE STARTING ENGINE	4.4.16
STARTING ENGINE USING AIRPLANE POWER	4.4.21
STARTING ENGINE USING EXTERNAL POWER (GPU)	4.4.27
MOTORING	4.4.34

TABLE OF CONTENTS
(Continued)

	Page
MOTORED FOLLOWED BY AN ENGINE START	4.4.37
AFTER STARTING ENGINE	4.4.40
IN-FLIGHT AVAILABLE OXYGEN QUANTITY	4.4.44
TAXIING	4.4.45
BEFORE TAKEOFF	4.4.47
TAKEOFF	4.4.50
CLIMB	4.4.53
CRUISE	4.4.55
DESCENT	4.4.57
BEFORE LANDING	4.4.59
LANDING	4.4.61
GO-AROUND	4.4.62
TOUCH AND GO	4.4.63
AFTER LANDING	4.4.64
SHUT-DOWN	4.4.65
4.5 PARTICULAR PROCEDURES	4.5.1
FLIGHT INTO KNOWN ICING CONDITIONS	4.5.1
FLIGHT INTO SEVERE ICING CONDITIONS	4.5.6
FLIGHT UNDER HEAVY PRECIPITATIONS	4.5.8
UTILIZATION ON RUNWAYS COVERED WITH WATER	4.5.8
UTILIZATION ON RUNWAYS COVERED WITH MELTING OR NOT TAMPED SNOW	4.5.9
UTILIZATION ON ICY OR COVERED WITH TAMPED SNOW RUNWAYS	4.5.11
UTILIZATION BY COLD WEATHER (- 0°C to - 25°C) AND VERY COLD WEATHER (- 25°C to - 40°C)	4.5.13
ENVELOPE 1	4.5.14
ENVELOPE 2	4.5.16
ENVELOPE 3	4.5.21
LANDING PROCEDURE WITH STRONG HEADWIND OR CROSSWIND	4.5.23
UTILIZATION ON GRASS RUNWAY	4.5.25
OPERATION IN RVSM CONDITIONS	4.5.26

4.1 - GENERAL

This Section provides procedures for the conduct of normal operation of TBM 700 airplane.

The first part of this Section lists the normal procedures required as a check list.

The amplified procedures are developed in the second part of the Section.

The normal procedures for optional systems are given in Section 9, "Supplements" of the Pilot's Operating Handbook.

INTENTIONALLY LEFT BLANK

4.2 - AIRSPEEDS FOR NORMAL OPERATION

(Refer to Supplement 41 for TBM 700C2 airplane)

CONDITIONS : - Takeoff weight : 6579 lbs (2984 kg)
 - Landing weight : 6250 lbs (2835 kg)

- 1 Rotation airspeed (V_R)
 - Flaps TO Depending on weight
 (See "Takeoff distances" Chapter 5.8)
- 2 Best rate of climb speed (V_Y)
 - Landing gear UP, flaps UP 123 KIAS
- 3 Best angle of climb speed (V_X) 95 KIAS
- 4 Maximum speed : Flaps TO 178 KIAS
 Flaps LDG 122 KIAS
- 5 Maximum speed with landing gear down 178 KIAS
- 6 Maximum landing gear operating speed
 - Extension 178 KIAS
 - Retraction 128 KIAS
- 7 Approach speed
 - Flaps LDG 80 KIAS
- 8 Maximum operating speed (V_{MO}) 266 KIAS
- 9 Glide speed (maximum L / D ratio)
 - Landing gear UP, flaps UP 120 KIAS
- 10 Maximum inertial separator operating speed 200 KIAS

INTENTIONALLY LEFT BLANK

4.3 - CHECK-LIST PROCEDURES

PREFLIGHT INSPECTION

(See Figure 4.3.1)

IMPORTANT

- * During outside inspection, visually check inspection doors and airplane general condition.
- * In cold weather, remove even small accumulations of frost, ice or snow from wing, tail and control surfaces.
- * In case of night flight, check good operation of all navigation lights, landing lights, strobe lights and make sure that an emergency lamp is on board.
- * If icing conditions are foreseen, particularly check good functioning of all electrical and pneumatic ice protection systems
- * Check that type and quantity of fuel used for refueling are correct.
- * Remove covers on :
 - pitots (2)
 - static ports (3)
 - engine air inlet and propeller locking (1).
- * Remove tie-downs.
- * Refer to Section 8 for quantities, products and specifications of products and materials currently used.



CHECK-LIST PROCEDURES

PREFLIGHT INSPECTION (Cont'd)

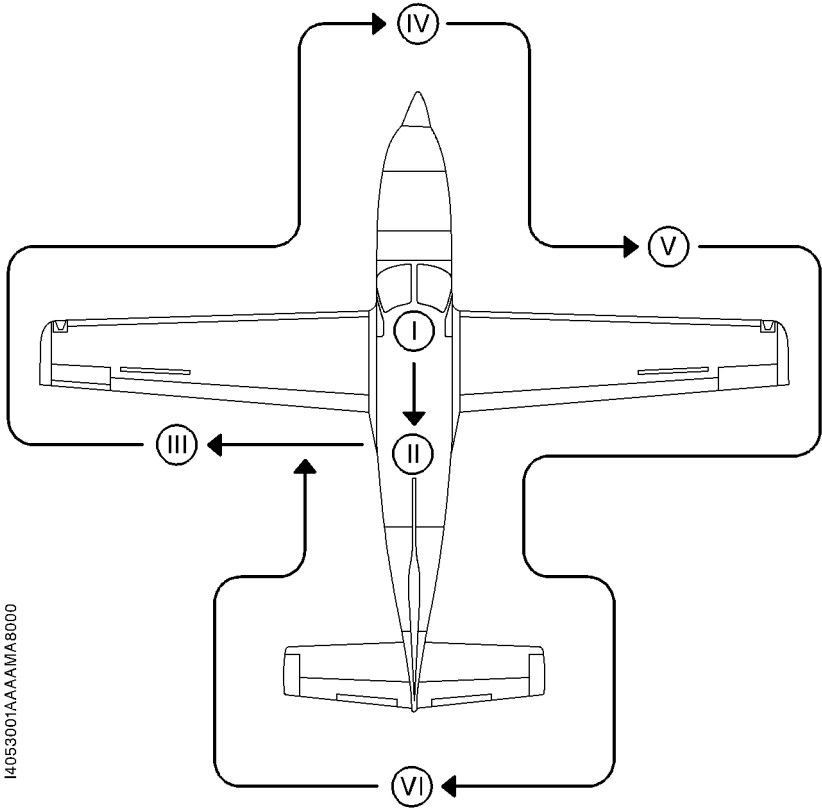

14053001AAAAA8000

Figure 4.3.1 - PREFLIGHT INSPECTION



CHECK-LIST PROCEDURES

PREFLIGHT INSPECTION (Cont'd)

A - INSIDE INSPECTIONS**Cockpit** (I)

- CRASH lever **UP**
- 1 - ELECTRIC POWER panel
 - "SOURCE" selector **OFF**
 - "GENERATOR" selector **MAIN**
- 2 - ENGINE START panel
 - "IGNITION" switch **AUTO or OFF**
 - "STARTER" switch **OFF**
- 3 - EXT LIGHTS panel
 - All switches **OFF**
- 4 - GYRO INST panel
 - All switches **OFF**
- 5 - Breakers panel
 - All breakers **ENGAGED**
- 6 - DE ICE SYSTEM panel
 - All switches **OFF**
- 7 - Landing gear control **DN**
- 8 - Landing gear emergency control
 - Lever **PULLED DOWN**
 - By-pass selector **PUSHED**
 - Door **IN PLACE**
- 9 - "AP / TRIMS MASTER" switch **OFF**
- 10 - "RADIO MASTER" switch **OFF**



CHECK-LIST PROCEDURES

PREFLIGHT INSPECTION (Cont'd)

- 11 - ECS panel
 - "BLEED" switch **OFF**
 - "AIR COND" switch **OFF**
 - "DUMP" switch **GUARDED**
- 12 - "RAM AIR" control knob **PUSHED**
- 13 - Fuel
 - "FUEL SEL" selector **MAN**
 - "AUX BP" switch **OFF**
 - Tank selector **L or R**
- 14 - ELT **ARM**
- 15 - Flight control lock **REMOVED / STOWED**
- 16 - Flight controls **Deflections checked**
- 17 - Parking brake **SET**
- 18 - Engine controls
 - "MAN OVRD" control **OFF (Notched)**

CAUTION
**WHEN THE ENGINE IS SHUTDOWN, THE POWER LEVER
MUST NOT BE MOVED BEHIND THE FLIGHT IDLE
POSITION**

- Power lever **IDLE
(Flight idle stop)**
- Propeller governor lever **MAX. RPM**
- Condition lever **CUT OFF**

- 19 - Flaps control **UP**



CHECK-LIST PROCEDURES

PREFLIGHT INSPECTION (Cont'd)

- 20 - BAT BUS power supply
 - Stop watch **CHECKED**
 - Access lighting **CHECKED**
 - Emergency lighting **CHECKED**

CAUTION

BEFORE SELECTING SOURCE, CHECK :

- 21 - "IGNITION" switch AUTO or OFF**
- 22 - "STARTER" switch OFF**
- 23 - Landing gear control DN**

- 24 - "SOURCE" selector **BAT or GPU**
- 25 - Voltage **CHECK**
 - BAT **> 25 Volts**
 - GPU **≈ 28 Volts**
- 26 - EXT LIGHTS panel
 - "LTS TEST" push button **PRESS**
(3 green lamps "L.LDG / TAXI / R.LDG" ON)
 - "L.LDG / TAXI / R.LDG" switches **ON**
(3 green lamps ON)
 - "L.LDG / TAXI / R.LDG" switches **OFF**
- 27 - Fuel gages
 - Operation / quantity **CHECK**
- 28 - ADVISORY PANEL
 - Test 1 **ALL WARNING LIGHTS ON**
 - Test 2 **ALL WARNING LIGHTS ON**
- 29 - Oxygen emergency

system **WARNING LIGHT**

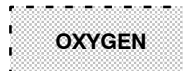

OFF



CHECK-LIST PROCEDURES

PREFLIGHT INSPECTION (Cont'd)

30 - INT LIGHTS panel **CHECK**

31 - ECS panel
 - "LT TEST" push button **PRESS**
(amber indicator light ON)

32 - Flaps **LDG**

33 - Landing gear panel **Warning lights : 3 GREEN ON**
Test 1, then 2 : RED ON + 3 GREEN ON

34 - "PITOT 1 HTR" switch **ON**

	WARNING LIGHT	PITOT 1	OFF
--	----------------------	----------------	------------

35 - "PITOT 2 & STALL HTR" switch **ON**

	WARNING LIGHTS	PITOT 2	OFF
		STALL HTR	

"PITOT 1 HTR" switch **OFF**

"PITOT 2 & STALL HTR" switch **OFF**

36 - DE ICE SYSTEM panel
 - "LTS TEST" push button **PRESS**
(All green lights ON)

WARNING

**DO NOT TOUCH PITOTS NOR STALL WARNING VANE.
 THEY COULD BE HOT ENOUGH TO BURN SKIN**



CHECK-LIST PROCEDURES

PREFLIGHT INSPECTION (Cont'd)

- 37 - EXT LIGHTS panel
- "STROBE" **ON**
 - "NAV" **ON**
 - "ICE LIGHT" **ON**

From outside the airplane, check operation of all lights and the stall warning horn

- 38 - Reentering the airplane
- EXT LIGHTS panel **ALL SWITCHES OFF**
 - DE ICE SYSTEM panel **ALL SWITCHES OFF**
- 39 - "SOURCE" selector **OFF**

Cabin (II)

- 1 - Cabin fire extinguisher **CHECK**
(Pressure / Attachment)
- 2 - Seats / belts **CHECK**
- 3 - Windows **CHECK**
(General condition / No crack)
- 4 - Emergency exit **CLOSED / LOCKED**
- Anti-theft safety **REMOVE / STOW**
- 5 - Baggage compartment **STRAPS IN PLACE**
- 6 - Partition net **IN PLACE**
- 7 - Doors operation **CHECK**
- 8 - Stairs condition **CHECK**
(Condition / Play)



CHECK-LIST PROCEDURES

PREFLIGHT INSPECTION (Cont'd)

B - AIRPLANE OUTSIDE

L.H. wing (III)

- 1 - Flap **CHECK**
(Condition / Play)
- 2 - Aileron and trim / Spoiler **CHECK**
(Condition / Free movement / Deflection)
- 3 - Trailing edge static discharger **CHECK**
(Condition / Attachment)
- 4 - Wing tip / nav. lights /
Strobe / landing light **Condition - CHECK**
- 5 - OAT probe **Condition - CHECK**
- 6 - Fuel tank **CAP CLOSED / LOCKED**
- 7 - Fuel tank air vent **Unobstructed - CHECK**
- 8 - External pitot (IAS) **Condition - CHECK**
- 9 - Internal pitot (V_{MO}) **Condition - CHECK**
- 10 - Wing lower surface **CHECK**
(No leak)
- 11 - Wing deicer boots **CHECK**
(Condition / Attachment)
- 12 - Fuel tank drain (two on each wing) **DRAIN**
(Fuel free of water and contamination)



CHECK-LIST PROCEDURES

PREFLIGHT INSPECTION (Cont'd)

- 13 - L.H. main landing gear
 - Shock absorber / doors /
 tire / wheel well **CHECK**

Fuselage forward section (IV)

- 1 - Forward compartment
 - Inside **CONTROLLED**
 - Door **CLOSED / LOCKED**
- 2 - GPU door **CLOSED**
 (If not used)
- 3 - Fuel circuit drain **DRAIN**
 (Fuel free of water and contamination)
 - Filter contamination indicator **CHECK**
- 4 - L.H. exhaust stub **CHECK**
 (Condition / No crack)
- 5 - Upper engine cowls **OPEN**
 For the first flight of the day :
 - Oil cap **CLOSED / LOCKED**
 - Engine oil level **CHECK**
 - Fuel pipes **CHECK**
 (No leak, deterioration, wear)
- 6 - Engine cowls **Condition - CHECK**
CLOSED / LOCKED
- 7 - Air inlets
 - Main **No crack - UNOBSTRUCTED**
 - Lateral / upper **UNOBSTRUCTED**



CHECK-LIST PROCEDURES

PREFLIGHT INSPECTION (Cont'd)

8 - Propeller and spinner **CHECK**
(No nicks, cracks or oil leaks / Attachment)

9 - Nose gear
- Landing light / shock absorber / doors /
tire / wheel well **CHECK**

10 - R.H. exhaust stub **CHECK**
(Condition / No cracks)

R.H. wing (V)

1 - Fuel tank drain (two on each wing) **DRAIN**
(Fuel free of water and contamination)

2 - Main landing gear
- Shock absorber / doors /
tire / wheel well **CHECK**

3 - Wing deicer boots **CHECK**
(Condition / Attachment)

4 - Stall warning **CHECK**
(Condition / Deflection)

5 - Wing lower surface **CHECK**
(No leaks)

6 - Fuel tank **CAP CLOSED / LOCKED**

7 - Fuel tank air vent **Unobstructed - CHECK**

8 - Wing tip / nav. light /
strobe / landing light **Condition - CHECK**

9 - Trailing edge static discharger **CHECK**
(Condition / Number / Attachment)



CHECK-LIST PROCEDURES

PREFLIGHT INSPECTION (Cont'd)

- 10 - Aileron / spoiler **CHECK**
(Condition / Free movement / Deflection)
- 11 - Flap **CHECK**
(Condition / Play)
- 12 - Rear R.H. karman **Oxygen cylinder open**
- 13 - Oxygen pressure **CHECK**

Fuselage rear section / Empennages (VI)

- 1 - ELT **OFF**
- 2 - Static pressure ports **CLEAN - CHECK**
- 3 - Ventral fins **CHECK**
(Attachment condition)
- 4 - Inspection door under fuselage **CLOSED - CHECK**
(Attachments)
- 5 - Horizontal stabilizer
deicer boots (R.H. side) **CHECK**
(Condition / Attachments)
- 6 - Elevator and trim **CHECK**
(Condition / Deflection free movement / Trim position)
- 7 - Static dischargers **CHECK**
(Condition)
- 8 - Vertical stabilizer deicer boots **CHECK**
(Condition / Attachments)
- 9 - Rudder and trim **CHECK**
(Condition / Trim position)



CHECK-LIST PROCEDURES

PREFLIGHT INSPECTION (Cont'd)

- 10 - Static dischargers **CHECK
(Condition)**
- 11 - Tail cone **Condition - CHECK**
- 12 - Static pressure ports **Clean - CHECK**
- 13 - Rear baggage compartment
 - Inside **CONTROLLED**
 - Door **CLOSED / LOCKED**

CHECK-LIST PROCEDURES

BEFORE STARTING ENGINE (1/3)

(Refer to Supplement 41 for TBM 700C2 airplane)

CAUTION

"BLEED" SWITCH "ON" MAY CAUSE OVERTEMPERATURE OR ABNORMAL ACCELERATION AT START

CAUTION

MAKE SURE THAT "MAN OVRD" CONTROL IS "OFF" TO AVOID OVERTEMPERATURE RISKS AT START

- 1 - Preflight inspection **COMPLETED**
- 2 - Cabin access door **CLOSED / LOCKED**
- 3 - "Pilot" door (if installed) **CLOSED / LOCKED**
- 4 - Baggage **STOWED**
- 5 - Parking brake **SET**
- 6 - Weight and balance **COMPUTED / CHECKED**
- 7 - Seats
 - Pilot **ADJUSTED**
 - R.H. front station **If not occupied by a second pilot :
adjust seat so as not to hinder
full travel of flight controls**

If the airplane is equipped with option OPT70 01029 "Provision for TBM 700C2" :

- Pilot seat and R.H. front seat (if occupied)
 - . Height adjustment **Maximum UP**
 - . Fore and aft adjustment . **ADJUST and CHECK LOCKING**
 - . Height adjustment **ADJUST**
- 8 - R.H and L.H. pedals **ADJUSTED**



CHECK-LIST PROCEDURES

BEFORE STARTING ENGINE (2/3)

- 9 - Belts and harnesses (Pilot and passengers) **FASTENED**
- 10 - Crash lever **UP**
- 11 - Oxygen supply **Available for the planned flight**
(see tables of paragraph "IN-FLIGHT AVAILABLE
OXYGEN QUANTITY" and Chapter 7.10
for a FAR 135 type operation)
- 12 - "OXYGEN" switch **ON**
- 13 - "PASSENGERS OXYGEN" switch **OFF**
- 14 - Copilot and pilot masks **Press push-button**
"PRESS TO TEST" : the blinker shall turn red
momentarily, then turns transparent
- 15 - "NORMAL/MASK" micro inverter **NORMAL**
- 16 - "IGNITION" switch **AUTO or OFF**
- 17 - "STARTER" switch **OFF**
- 18 - Landing gear control **DN**
- 19 - "RADIO MASTER" switch **ON**
- 20 - RADIO VHF1 **ON - ADJUSTED**
- 21 - Authorization for engine starting **ASKED**
- 22 - ETM
 - Fuel remaining **Check**
 - Added fuel **Insert**
 - Fuel flow page **Select**
- 23 - "SOURCE" selector **BAT (or GPU)**
- 24 - "BAT TEMP TEST" push-button
(Cadmium-Nickel battery, if installed) **PRESS**
- 25 - Passengers briefing **AS REQUIRED**



CHECK-LIST PROCEDURES

BEFORE STARTING ENGINE (3/3)

26 - Access door and

(if installed) "pilot" door **WARNING LIGHT** **DOOR** **OFF**

27 - Fuel

- Gages **CHECKED**- Tank selector **L or R - CHECKED**- "FUEL SEL" switch **AUTO****WARNING LIGHT** **AUTO SEL** **OFF**- "SHIFT" push-button **PRESS****The selector changes tank****On ground, observe a tank change
every minute and 15 seconds**28 - ETM fuel flowmeter totalizer **CHECKED - ADJUSTED**29 - Engine instruments **CHECK**30 - ITT TEST **CARRY OUT**

31 - EXT LIGHTS panel

- "STROBE" **AS REQUIRED**

32 - In case of night flight

- INT LIGHTS panel : "INSTR" + "PANEL" **ADJUSTED**- Navigation lights **ON**- Flashlight (if necessary) **IN PLACE**

CHECK-LIST PROCEDURES

**STARTING ENGINE USING AIRPLANE POWER
(1/5)**

CAUTION

BEFORE SELECTING SOURCE, CHECK :

- 1 - "IGNITION" switch AUTO or OFF**
- 2 - "STARTER" switch OFF**
- 3 - "INERT SEP" switch OFF**
- 4 - Landing gear control DN**

- 5 - ELECTRIC POWER panel
 - "SOURCE" selector **BAT**
 - Voltage **CHECKED**
> 25 Volts

- 6 - Engine controls
 - "MAN OVRD" control **OFF (Notched)**

CAUTION

**WHEN THE ENGINE IS SHUTDOWN, THE POWER LEVER
MUST NOT BE MOVED BEHIND THE FLIGHT IDLE
POSITION**

- Power lever **IDLE**
(Flight idle stop)
- Propeller governor lever **MAX RPM**
- Condition lever **CUT OFF**



CHECK-LIST PROCEDURES

STARTING ENGINE USING AIRPLANE POWER (2/5)

7 - FUEL panel
 - "AUX BP" switch ON

WARNING LIGHT AUX BP ON ON

WARNING LIGHT FUEL PRESS OFF

- Fuel pressure indicator **Green sector**

8 - Propeller **AREA CLEAR**

9 - ENGINE START panel

- "IGNITION" switch **AUTO**

- "STARTER" switch **ON**

WARNING LIGHTS STARTER FLASHING

IGNITION ON

NOTE :

The utilization of the starter is bound by limitations mentioned in Chapter 2.4 "STARTER OPERATION LIMITS".

Ng \simeq 13 %

- Condition lever **LO / IDLE**

Monitor increase of :

- ITT **(max. ITT : 870°C for 20 seconds max.
 1000°C for 5 seconds max.)**

- Ng

- Oil pressure WARNING LIGHT OIL PRESS OFF

10 - "STARTER" switch **OFF**
 Check Ng > 52 %



CHECK-LIST PROCEDURES

**STARTING ENGINE USING
 AIRPLANE POWER (3/5)**

11 - Condition lever **HI / IDLE**

■ 12 - Engine instruments **CHECK : Ng \simeq 68 % (\pm 1 %)**
(Oil pressure / Oil temperature / ITT = green sector)

13 - FUEL panel
 - "AUX BP" switch **AUTO**

	WARNING LIGHT	AUX BP ON	OFF
--	----------------------	------------------	------------

14 - Generator	WARNING LIGHT	MAIN GEN	OFF
----------------------	----------------------	-----------------	------------

- RESET if necessary**
- Battery ammeter **CHARGE CHECKED**
- Battery voltage **CHECKED**
(V \simeq 28 Volts)

CAUTION

IF 10 SECONDS AFTER HAVING POSITIONED CONDITION LEVER TO "LO / IDLE" THERE IS NO IGNITION OR IF DURING IGNITION SEQUENCE, OVERTEMPERATURE INDICATION APPEARS (MAX. ITT : 870°C FOR MORE THAN 20 SECONDS - 1000°C FOR MORE THAN 5 SECONDS),

INTERRUPT STARTING PROCEDURE :

Condition lever **CUT OFF**

"IGNITION" switch **OFF (or AUTO)**

Wait ITT < 800°C, then :

"STARTER" switch **OFF**

BEFORE ANY RESTARTING ATTEMPT, CARRY OUT A MOTORING (Refer to paragraph "MOTORING")



CHECK-LIST PROCEDURES

**STARTING ENGINE USING
AIRPLANE POWER (4/5)**

CAUTION

**IF ENGINE STAGNATES,
INTERRUPT STARTING PROCEDURE :**

Condition lever CUT OFF
"IGNITION" switch OFF (or AUTO)
"STARTER" switch OFF

**WAIT FOR 1 MINUTE (Refer to Chapter 2.4 "STARTER OPERATION
LIMITS"), THEN TRY TO RESTART**

ENGINE START panel

- "IGNITION" switch **AUTO**
- "STARTER" switch **ON**

WARNING LIGHTS

STARTER

FLASHING

IGNITION

ON

Ng ≈ 13 %

- Condition lever **HI / IDLE**

Monitor increase of :

- ITT (max. ITT : 870°C for 20 seconds max.
1000°C for 5 seconds max.)
- Ng

- Oil pressure WARNING LIGHT

OIL PRESS

OFF



CHECK-LIST PROCEDURES

**STARTING ENGINE USING
AIRPLANE POWER (5/5)**

Ng \simeq 50 %

- "STARTER" switch OFF

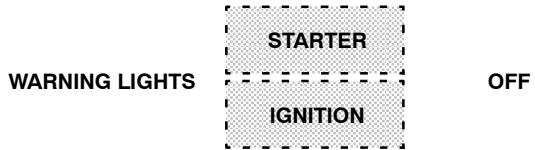

■ Engine instruments **CHECK Ng increasing to 68 % (\pm 1 %)**
(Oil pressure / ITT = green sector)

NOTE :

This behaviour should only be observed with outside low temperature (IOAT < 0 °C), cold engine.

This procedure may be used for the first starting of the day.

CHECK-LIST PROCEDURES

**STARTING ENGINE USING
EXTERNAL POWER (GPU) (1/5)**

1 - GPU **CONNECTED**

CAUTION

BEFORE SELECTING SOURCE, CHECK :

- 2 - "IGNITION" switch **AUTO or OFF**
- 3 - "STARTER" switch **OFF**
- 4 - "INERT SEP" switch **OFF**
- 5 - Landing gear control **DN**

6 - "SOURCE" selector **GPU**

WARNING LIGHT



ON

WARNING LIGHT



ON

- Voltmeter **VOLTAGE CHECKED**
(V ≈ 28 Volts)

7 - Engine controls

- "MAN OVRD" control **OFF (Notched)**

CAUTION

**WHEN THE ENGINE IS SHUTDOWN, THE POWER LEVER
MUST NOT BE MOVED BEHIND THE FLIGHT IDLE
POSITION**

- Power lever **IDLE**
(Flight idle stop)

- Propeller governor lever **MAX RPM**

- Condition lever **CUT OFF**



CHECK-LIST PROCEDURES

**STARTING ENGINE USING
 EXTERNAL POWER (GPU) (2/5)**

- 8 - FUEL panel
 - "AUX BP" switch **ON**

WARNING LIGHTS	AUX BP ON	ON
	FUEL PRESS	OFF

- Fuel pressure indicator **CHECK**

- 9 - Propeller **AREA CLEAR**

- 10 - ENGINE START panel
 - "IGNITION" switch **AUTO**
 - "STARTER" switch **ON**

WARNING LIGHTS	STARTER	FLASHING
	IGNITION	ON

NOTE :
 The utilization of the starter is bound by limitations mentioned in Chapter 2.4 "STARTER OPERATION LIMITS".

- Ng \simeq 13 %
 - Condition lever **LO / IDLE**

- Monitor increase of :
 - ITT **(max. ITT : 870°C for 20 seconds max.
 1000°C for 5 seconds max.)**

- Ng
 - Oil pressure **WARNING LIGHT**

	OIL PRESS	OFF
--	------------------	------------



CHECK-LIST PROCEDURES

STARTING ENGINE USING EXTERNAL POWER (GPU) (3/5)

11 - "SOURCE" selector **BAT**

WARNING LIGHT **BAT OFF** **OFF**

12 - Propeller governor lever **FEATHER**

13 - GPU **HAVE IT DISCONNECTED**

WARNING LIGHT **GPU** **OFF**

14 - Condition lever **HI / IDLE**

15 - Propeller governor lever **MAX. RPM**

■ 16 - Engine instruments **CHECK : Ng \simeq 68 % (\pm 1 %)**
(Oil pressure / Oil temperature / ITT = green sector)

17 - FUEL panel
- "AUX BP" switch **AUTO**

WARNING LIGHT **AUX BP ON** **OFF**

18 - Generator **WARNING LIGHT** **MAIN GEN** **OFF**

RESET if necessary
- Battery ammeter **CHARGE CHECKED**
- Battery voltage **CHECKED**
(V \simeq 28 Volts)



CHECK-LIST PROCEDURES

**STARTING ENGINE USING
EXTERNAL POWER (GPU) (4/5)**

CAUTION

IF 10 SECONDS AFTER HAVING POSITIONED CONDITION LEVER TO "LO / IDLE" THERE IS NO IGNITION OR IF DURING IGNITION SEQUENCE, OVERTEMPERATURE INDICATION APPEARS (MAX. ITT : 870°C FOR MORE THAN 20 SECONDS - 1000°C FOR MORE THAN 5 SECONDS),

INTERRUPT STARTING PROCEDURE :

Condition lever CUT OFF

"IGNITION" switch OFF (or AUTO)

Wait ITT < 800°C, then :

"STARTER" switch OFF

**BEFORE ANY RESTARTING ATTEMPT, CARRY OUT A MOTORING
(Refer to paragraph "MOTORING")**

CAUTION

IF ENGINE STAGNATES,

INTERRUPT STARTING PROCEDURE :

Condition lever CUT OFF

"IGNITION" switch OFF (or AUTO)

"STARTER" switch OFF

WAIT FOR 1 MINUTE (Refer to Chapter 2.4 "STARTER OPERATION LIMITS"), THEN TRY TO RESTART



CHECK-LIST PROCEDURES

STARTING ENGINE USING EXTERNAL POWER (GPU) (5/5)

ENGINE START panel

- "IGNITION" switch **AUTO**
- "STARTER" switch **ON**

WARNING LIGHTS

STARTER

FLASHING

IGNITION

ON

Ng \simeq 13 %

- Condition lever **HI / IDLE**

Monitor increase of :

- ITT (**max. ITT : 870°C for 20 seconds max.
 1000°C for 5 seconds max.**)
- Ng

- Oil pressure **WARNING LIGHT**

OIL PRESS

OFF

Ng \simeq 50 %

- "STARTER" switch **OFF**

WARNING LIGHTS

STARTER

OFF

IGNITION

Engine instruments **CHECK Ng increasing to 68 % (\pm 1 %)
 (Oil pressure / ITT = green sector)**

NOTE :

*This behaviour should only be observed with outside low temperature
 (IOAT < 0 °C), cold engine.*

This procedure may be used for the first starting of the day.

CHECK-LIST PROCEDURES

MOTORING (1/2)

CAUTION

AFTER ANY STARTING INTERRUPT PROCEDURE :

- **WAIT FOR ENGINE TOTAL SHUT-DOWN**
- **WAIT AT LEAST 30 SECONDS BEFORE INITIATING A MOTORING**

- 1 - Engine controls
 - "MAN OVRD" control **OFF (Notched)**

CAUTION

**WHEN THE ENGINE IS SHUTDOWN, THE POWER LEVER
 MUST NOT BE MOVED BEHIND THE FLIGHT IDLE
 POSITION**

- Power lever **IDLE
 (Flight idle stop)**
- Propeller governor lever **MAX. RPM**
- Condition lever **CUT OFF**

- 2 - Fuel
 - Tank selector **L or R**
 - "AUX BP" switch **ON**

WARNING LIGHTS

AUX BP ON

ON

FUEL PRESS

OFF



CHECK-LIST PROCEDURES

MOTORING (2/2)

3 - "IGNITION" switch OFF
 WARNING LIGHT IGNITION OFF

To clear fuel and vapor internally trapped :

4 - "STARTER" switch ON
 during 15 sec maxi
 WARNING LIGHT STARTER FLASHING

To cool engine following shut-down in high temperature environment :

4 - "STARTER" switch ON
 during 30 sec
 WARNING LIGHT STARTER FLASHING

5 - "STARTER" switch OFF
 WARNING LIGHT STARTER OFF

6 - FUEL panel
 - "AUX BP" switch OFF
 WARNING LIGHTS AUX BP ON OFF
FUEL PRESS ON

CHECK-LIST PROCEDURES

**MOTORING FOLLOWED BY AN ENGINE START
(1/2)**

Within starter operating limits (continuous max. 1 minute), it is possible to initiate a starting procedure from a motoring procedure.

- 1 - Engine controls
 - "MAN OVRD" control **OFF (Notched)**

CAUTION

**WHEN THE ENGINE IS SHUTDOWN, THE POWER LEVER
MUST NOT BE MOVED BEHIND THE FLIGHT IDLE
POSITION**

- Power lever **IDLE**
(Flight idle stop)
- Propeller governor lever **MAX. RPM**
- Condition lever **CUT OFF**
- 2 - Fuel
 - Tank selector **L or R**
 - "AUX BP" switch **ON**

WARNING LIGHTS	AUX BP ON	ON
	FUEL PRESS	OFF

- 3 - "IGNITION" switch **OFF**
- 4 - "STARTER" switch **ON during 15 sec**
- 5 - After 15 seconds :
 - "IGNITION" switch **AUTO**
 - Ng **Check at 13 % minimum**
 - Condition lever **LO / IDLE**



CHECK-LIST PROCEDURES

MOTING FOLLOWED BY AN ENGINE START (2/2)

6 - Monitor increase of :

- ITT (max. ITT : 870°C for 20 seconds max.
 1000°C for 5 seconds max.)

- Ng

- Oil pressure **WARNING LIGHT** OIL PRESS **OFF**

Ng \simeq 50 % stable

- "STARTER" switch **OFF**

WARNING LIGHTS STARTER **OFF**

IGNITION **OFF**

7 - Engine instruments **CHECK : Ng > 52 %**
 (Oil pressure / ITT = green sector)

8 - Condition lever **HI / IDLE**

9 - Engine instruments **CHECK : Ng \simeq 68 % (\pm 1 %)**
 (Oil pressure / Oil temperature / ITT = green sector)

10 - FUEL panel

- "AUX BP" switch **AUTO**

WARNING LIGHT AUX BP ON **OFF**

11 - Generator **WARNING LIGHT** MAIN GEN **OFF**

RESET if necessary

- Battery ammeter **CHARGE CHECKED**

- Battery voltage **CHECKED**
 (V \simeq 28 Volts)

CHECK-LIST PROCEDURES

AFTER STARTING ENGINE (1/2)

1 - GYRO INST panel
 - All switches **ON**
 Pull on the caging knobs when starting the ADI(s).

2 - Gyroscopic suction gage indicator **GREEN SECTOR**
WARNING LIGHT VACUUM LO **OFF**

3 - GYRO SLAVING selector **SLAVE**

4 - DE ICE SYSTEM panel
 - "PROP DE ICE" switch **ON**

Check illumination of the green light located above the switch

- "PROP DE ICE" switch **OFF**
 - "L.WINDSHIELD" switch **ON**
 - "R.WINDSHIELD" switch **ON**

Check illumination of the green light located above the switch (except if hot conditions)

- "L.WINDSHIELD" switch **OFF**
 - "R.WINDSHIELD" switch **OFF**

Increase power so as to get $N_g \geq 80\%$ to check AIRFRAME DE ICE

- "AIRFRAME DE ICE" switch **ON**
Visually check functioning of deicer boots during 1 total cycle and illumination of the two green lights located above the switch

- "AIRFRAME DE ICE" switch **OFF**
 - "INERT SEP" switch **ON**

WARNING LIGHT

INERT SEP

ON
 after 30 seconds



CHECK-LIST PROCEDURES

AFTER STARTING ENGINE (2/2)

- 5 - "GENERATOR" selector
 - On "MAIN" **Voltage and current checked**

when current \leq 50 amps :

 - on "ST-BY" **Voltage and current checked**
 (reset if necessary)
 - then again on "MAIN"

- 6 - Flaps **UP**

- 7 - ECS panel
 - "BLEED" switch **ON**
 - "FAN FLOW" switch **As required**
 - "AIR COND" switch **ON**
 - "CABIN TEMP/°C" selector **ADJUST**
 - "AIR FLOW" distributor **AS REQUIRED**
 - Cabin altitude selector **Airfield altitude - 500 feet**
 - Cabin rate selector **ARROW UPWARDS**
 (at the halfway post)

- 8 - "RADIO MASTER" switch **ON**
 - VHF/VOR/GPS/TAS/
 EGPWS/WX means (if installed) **ADJUSTED - TESTED**

- 9 - "EFIS MASTER" switch **ON**
 - "TEST / CMPST" button **PRESS**
 - "TST / REF" button **PRESS at least 3 seconds**

- 10 - "AP / TRIMS MASTER" switch **ON**
 - Preflight test button **PRESS**
 - "AP / TRIMS MASTER" operation **CHECK**
 - Pitch trim **UP / DN, then ADJUSTED**
 - Yaw trim **L / R, then ADJUSTED**
 - Roll trim **L / R, then ADJUSTED**

CHECK-LIST PROCEDURES

**IN-FLIGHT AVAILABLE
 OXYGEN QUANTITY**

Oxygen pressure **Read**

Outside air temperature (IOAT) **Read**

1 - Determine the usable oxygen percent using the chart Figure 4.3.2.

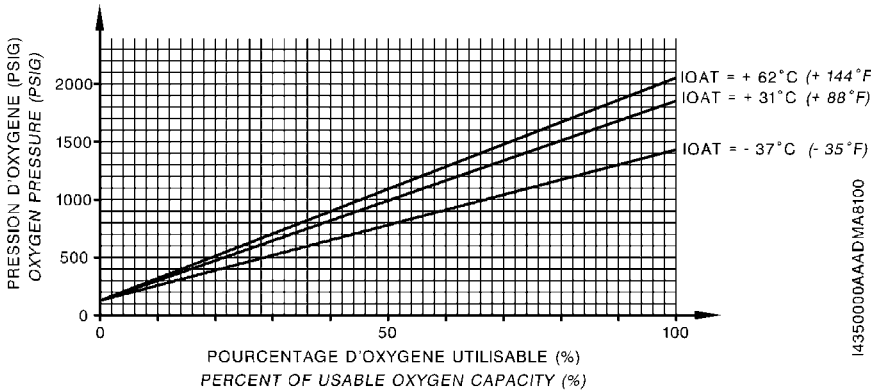

Figure 4.3.2

2 - Determine the oxygen duration in minutes by multiplying the values read on table Figure 4.3.3 by the percent obtained with the chart Figure 4.3.2.

Number of passengers	Duration : Passengers, plus 1 pilot	Duration : Passengers, plus 2 pilots
0	226	113
1	162	94
2	127	81
3	104	71
4	88	65

Figure 4.3.3

CHECK-LIST PROCEDURES

TAXIING

- | | |
|--------------------------------------|--------------------|
| 1 - "TAXI" light | ON |
| 2 - "INERT SEP" switch | CHECKED ON |
| CHECK WARNING LIGHT | INERT SEP |
| | ON |
| 3 - Passenger briefing | AS REQUIRED |
| 4 - Parking brake | RELEASED |
| WARNING LIGHT | PARK BRAKE |
| | OFF |
| 5 - L.H. and R.H. seats brakes | CHECKED |
| 6 - Nose wheel steering | CHECKED |
| 7 - Power lever | AS REQUIRED |

CAUTION

AVOID USING REVERSE DURING TAXIING

- | | |
|------------------------------|--------------|
| 8 - Flight instruments | CHECK |
| 9 - Advisory panel | CHECK |

CHECK-LIST PROCEDURES

BEFORE TAKEOFF (1/2)			
1 -	Parking brake	SET	
	WARNING LIGHT	<div style="border: 2px solid black; padding: 2px; display: inline-block;">PARK BRAKE</div>	ON
2 -	Condition lever	HI / IDLE	
		[Ng : 68 % (± 1 %)]	
3 -	Propeller governor lever	FEATHER twice, then MAX. RPM	
4 -	Fuel		
	- Gages	CHECK (Quantity / Symmetry)	
	- "FUEL SEL"	CHECK AUTO	
	- "AUX BP"	CHECK AUTO	
5 -	Flaps	TO	
6 -	DE ICE SYSTEM panel		
	- "AIRFRAME DE ICE" switch	As required	
	- "PROP DE ICE" switch	As required	
<i>If runway is in good condition, without icing conditions :</i>			
	- "INERT SEP" switch	OFF	
	WARNING LIGHT	<div style="border: 1px dashed gray; padding: 2px; display: inline-block;">INERT SEP</div>	OFF
<i>If there is standing water or other contamination on the runway :</i>			
	- "INERT SEP" switch	Leave ON	
	WARNING LIGHT	<div style="border: 2px solid black; padding: 2px; display: inline-block;">INERT SEP</div>	ON
	- "L.WINDSHIELD" switch	As required	
	- "R.WINDSHIELD" switch	As required	



CHECK-LIST PROCEDURES

BEFORE TAKEOFF (2/2)

- "PITOT 1 HTR" switch ON
- "PITOT 2 & STALL HTR" switch ON
- 7 - Advisory panel CHECK
All warning lights OFF,
except

PARK BRAKE

 ON
and, if used

INERT SEP

 ON
- 8 - Electronic equipment /
Flight instruments / Radar CHECK / ADJUST
- 9 - Engine instruments CHECK
- 10 - Pilot's / Passengers' belts CHECK
- 11 - Flight controls DEFLECTIONS CHECKED
- 12 - Trims
 - Pitch ADJUSTED
 - Yaw ADJUSTED
 - Roll ADJUSTED
- 13 - Parking brake RELEASED
WARNING LIGHT

PARK BRAKE

 OFF
- 14 - "STROBE" switch ON

CAUTION DO NOT TAKE OFF IF BATTERY CHARGE > 50 Amperes
--

CHECK-LIST PROCEDURES

TAKEOFF (1/2)

(Refer to Supplement 41 for TBM 700C2 airplane)

WHEN LINED UP

CAUTION

- IF HEAVY PRECIPITATION, TURN IGNITION AND INERT SEP ON.
- IF ICING CONDITIONS ARE FORESEEN, REFER TO CHAPTER 4.5, PARAGRAPH "FLIGHT INTO KNOWN ICING CONDITIONS"

- 1 - Heading - HSI - Stand-by compass **CHECK**
 - Altimeter setting **CHECK**
- 2 - Horizon **Attitude + 2° - CHECK**
- 3 - Lights
 - "L.LDG / TAXI / R.LDG" **ON**
- 4 - Engine instruments **CHECK**
(ITT = green sector)
- 5 - Advisory panel **CHECK**
All warning lights OFF,
 - except**

INERT SEP

if used
 - except**

IGNITION

if used
- 6 - Radar switch **As required**



CHECK-LIST PROCEDURES

TAKEOFF (2/2)

7 - PROP O' SPEED GOVERNOR TEST

- Increase power until propeller RPM reaches 1900 RPM
- PROP O' SPEED **TEST : Maintain engaged**
- Observe that propeller RPM decreases by 50 to 250 RPM
- PROP O' SPEED **TEST : Release**
- Check that propeller RPM increases by a minimum of 50 RPM when compared to minimum value during PROP O'SPEED test.

8 - Brakes **RELEASED**9 - Power lever **TRQ = 100 %**10 - Takeoff **ROTATION : See "Takeoff distances" Chapter 5.8**

- Normal takeoff **ATTITUDE : 7° 5**
- Short takeoff **ATTITUDE : 15°**

11 - Vertical speed indicator **POSITIVE**12 - Brakes **APPLY (Briefly)**13 - Landing gear control (IAS < 128 KIAS) **UP**
At sequence end, check : All warning lights OFF

14 - Lights

- "TAXI" **OFF**
- "L.LDG / R.LDG" **AS REQUIRED**

15 - Initial climb speed **110 KIAS**16 - Flaps **UP**17 - Climb speed (recommended) **130 KIAS**18 - "YAW DAMPER" push-button **ON**

CHECK-LIST PROCEDURES

CLIMB

- 1 - Power lever **ADJUST** according to engine operation table - Chapter 5.7

CAUTION

**OBSERVE TRQ / Ng / Np / ITT / T°
AND OIL PRESSURE LIMITATIONS
AND / OR REFER TO TABLES IN CHAPTER 5.7**

- 2 - Climb speed **AS REQUIRED**
- 3 - ECS panel
- Cabin altitude selector **Cruise altitude + 1000 feet**
 - Cabin rate selector **ADJUST**
 - Pressurization **CHECK**
 - "CABIN TEMP/°C" selector **ADJUST**
- 4 - Fuel tank gages **CHECK / CORRECT**
(Quantity / Symmetry)
- 5 - DE ICE SYSTEM **As required**
Refer to Chapter 4.5
"PARTICULAR PROCEDURES"

CAUTION

**IF HEAVY PRECIPITATION, TURN IGNITION
AND INERT SEP ON**

CHECK-LIST PROCEDURES

CRUISE

- 1 - Power lever **ADJUST according to engine operation table - Chapter 5.7**

CAUTION
OBSERVE TRQ / Ng / Np / ITT / T°
AND OIL PRESSURE LIMITATIONS
AND / OR REFER TO TABLES IN CHAPTER 5.7

- 2 - Pressurization **CHECK**

- 3 - Fuel
- Gages **CHECK**

REGULARLY CHECK :

- **consumption**

Pre-MOD70-0402-28

- **tank automatic change (every 10 minutes)**

Post-MOD70-0402-28

- **tank automatic change (every 5 minutes)**

All

- **symmetry [max. dissymmetry 25 us gal (95 Litres)]**

- 4 - ETM
When the cruise parameters are fully established :
RECORD **Push**

- 5 - DE ICE SYSTEM **As required**
Refer to Chapter 4.5
"PARTICULAR PROCEDURES"

CAUTION
IF HEAVY PRECIPITATION, TURN IGNITION
AND INERT SEP ON

CHECK-LIST PROCEDURES

DESCENT

- 1 - Altimeter settings **COMPLETE**
- 2 - ECS panel
 - Cabin altitude selector **Airfield altitude + 500 feet**
 - Cabin rate selector **Adjusted**
- 3 - DE ICE SYSTEM **As required**
Refer to Chapter 4.5
"PARTICULAR PROCEDURES"

CAUTION

**IF HEAVY PRECIPITATION, TURN IGNITION
AND INERT SEP ON**

- 4 - Windshield misting protection system **As required**
- 5 - Fuel
 - Gages **CHECK**
(Quantity / Symmetry)
 - Fullest tank **SELECT**
- 6 - Passengers briefing **As required**
- 7 - Seats, belts and harnesses **LOCKED**

CHECK-LIST PROCEDURES

BEFORE LANDING

(Refer to Supplement 41 for TBM 700C2 airplane)

Long final

- | | |
|---|------------------------------|
| 1 - Altimeters | CHECK |
| 2 - Fuel | |
| - Gages | CHECK |
| | (Quantity / Symmetry) |
| - Fullest tank | SELECT |
| 3 - "INERT SEP" switch (IAS ≤ 200 KIAS) | ON |
| 4 - Propeller lever | MAX RPM |
| 5 - Landing gear control (IAS ≤ 178 KIAS) | DN |
| - Green indicator lights | ON |
| 6 - Flaps (IAS ≤ 178 KIAS) | TO |
| 7 - Lights | |
| - "L.LDG / TAXI / R.LDG" | ON |
| 8 - Autopilot | OFF |
| 9 - Radar switch | SBY |

Short final

- | | |
|---|----------------|
| 10 - Flaps (IAS ≤ 122 KIAS) | LDG |
| 11 - Approach speed (Flaps LDG) | 80 KIAS |
| 12 - "YAW DAMPER" push-button | OFF |

CHECK-LIST PROCEDURES

LANDING

1 - Power lever **IDLE**

After wheel touch

2 - Reverse **As required**
(Reverse may be applied as soon as the wheels touch the ground.)
To avoid ingestion of foreign objects, come out the reverse as speed reduces and use the brakes if necessary for further deceleration.

CAUTION

USE OF CONTROL REVERSE BETA (β) RANGE (BEHIND THE FLIGHT IDLE POSITION) IS PROHIBITED DURING FLIGHT

CAUTION

ON SNOWY OR DIRTY RUNWAY, IT IS BETTER NOT TO USE REVERSE

3 - Brakes **As required**

CHECK-LIST PROCEDURES

GO-AROUND**(Refer to Supplement 41 for TBM 700C2 airplane)**

- 1 - Simultaneously
 - Power lever **TRQ = 100 %**
 - Attitude **7° 5**

2 - Flaps **TO**

If the vertical speed is positive and if IAS is at or above 85 KIAS :

- 3 - Landing gear control **UP**
All warning lights OFF

If IAS is at or above 110 KIAS :

- 4 - Flaps **UP**
 5 - Climb speed **AS REQUIRED**

CHECK-LIST PROCEDURES

TOUCH AND GO

(Refer to Supplement 41 for TBM 700C2 airplane)

After wheel touch

- 1 - Flaps **TO**
- 2 - Elevator trim **Green sector**
- 3 - Power lever **Display TRQ = 100 %**
- 4 - Takeoff **ROTATION : See "Takeoff distances" Chapter 5.8**
 - Normal takeoff **ATTITUDE : 7° 5**
 - Short takeoff **ATTITUDE : 15°**

AFTER LANDING

RUNWAY CLEAR - AIRPLANE STOPPED

- 1 - DE ICE SYSTEM panel
 - "AIRFRAME DE ICE" switch **OFF**
 - "PROP DE ICE" switch **OFF**
 - "INERT SEP" switch **CHECKED ON**
 - "L.WINDSHIELD" switch **As required**
 - "R.WINDSHIELD" switch **As required**
 - "PITOT 1 HTR" switch **OFF**
 - "PITOT 2 & STALL HTR" switch **OFF**
 - "BLEED" switch **As required**
- 2 - Radar switch **CHECKED SBY**
- 3 - Transponder **SBY**
- 4 - Flaps **UP**
- 5 - Lights
 - "L.LDG / R.LDG" **OFF**
 - "TAXI" **ON**
- 6 - "STROBE" switch **OFF**
- 7 - "OXYGEN" switch **OFF**

CHECK-LIST PROCEDURES

SHUT-DOWN (1/2)

- 1 - Parking brake SET
- WARNING LIGHT PARK BRAKE ON
- 2 - "TAXI" light OFF
- 3 - Pressurization
 - "BLEED" switch OFF
 - Check for cabin depressurization
- 4 - "FAN FLOW" switch **As required**
- 5 - "AIR COND" switch OFF
- 6 - Condition lever **HI / IDLE**
- 7 - Power lever **IDLE for 2 minutes**
- 8 - GYRO INST panel
 - All switches OFF
- 9 - "EFIS MASTER" switch OFF
- 10 - "AP / TRIMS MASTER" switch OFF
- 11 - "RADIO MASTER" switch OFF
- 12 - Propeller governor lever **FEATHER for 15 seconds**
- 13 - Condition lever **CUT OFF**

CAUTION

IN CASE OF SHUT-DOWN ON A CONTAMINATED AREA :

- **Condition lever** **CUT OFF**
- **Propeller governor lever** **FEATHER**



CHECK-LIST PROCEDURES

SHUT-DOWN (1/2)

- | | |
|---------------------------------------|-----------------------------------|
| 1 - Parking brake | SET |
| WARNING LIGHT | PARK BRAKE |
| | ON |
| 2 - "TAXI" light | OFF |
| 3 - Pressurization | |
| - "BLEED" switch | OFF |
| - Check for cabin depressurization | |
| 4 - "FAN FLOW" switch | As required |
| 5 - "AIR COND" switch | OFF |
| 6 - Condition lever | HI / IDLE |
| 7 - Power lever | IDLE for 2 minutes minimum |
| 8 - GYRO INST panel | |
| - All switches | OFF |
| 9 - "EFIS MASTER" switch | OFF |
| 10 - "AP / TRIMS MASTER" switch | OFF |
| 11 - "RADIO MASTER" switch | OFF |
| 12 - Propeller governor lever | FEATHER for 15 seconds |
| 13 - Condition lever | CUT OFF |

CAUTION

**IN CASE OF SHUT-DOWN ON A CONTAMINATED
 AREA :**

- **Condition lever**
- **Propeller governor lever**



CHECK-LIST PROCEDURES

SHUT-DOWN (2/2)

- 14 - Fuel
 - "AUX BP" switch **OFF**
 - "FUEL SEL" switch **MAN**
 - Tank selector **OFF**
- 15 - "INERT SEP" switch **OFF**
- 16 - INT LIGHTS panel
 - All switches **OFF**
- 17 - EXT LIGHTS panel
 - All switches **OFF**
- 18 - "GENERATOR" selector **OFF**
- 19 - "SOURCE" selector **OFF**

CAUTION

**IN CASE OF HIGH OAT [ABOVE 35° C (95° F)], IT IS
REQUIRED TO PERFORM 30 SECONDS DRY
MOTORING RUN AFTER SHUT-DOWN TO IMPROVE
COOLING OF THE BEARING CAVITIES AND MINIMIZE
OIL COKING (REFER TO PARAGRAPH "MOTORING")**

CHECK-LIST PROCEDURES

SHUT-DOWN (2/2)

- 14 - Fuel
 - "AUX BP" switch **OFF**
 - "FUEL SEL" switch **MAN**
 - Tank selector **OFF**
- 15 - "INERT SEP" switch **OFF**
- 16 - INT LIGHTS panel
 - All switches **OFF**
- 17 - EXT LIGHTS panel
 - All switches **OFF**
- 18 - "GENERATOR" selector **OFF**
- 19 - "SOURCE" selector **OFF**

CAUTION

**IN CASE OF HIGH OAT [ABOVE 35° C (95° F)], IT IS
RECOMMENDED TO PERFORM 30 SECONDS DRY
MOTORING RUN AFTER SHUT-DOWN TO IMPROVE
COOLING OF THE BEARING CAVITIES AND
PREVENT OIL COKING (REFER TO PARAGRAPH
"MOTORING")**

4.4 - AMPLIFIED PROCEDURES

PREFLIGHT INSPECTION

A - INSIDE INSPECTIONS

Cockpit (1)

- CRASH lever **UP**
- 1 - ELECTRIC POWER panel
 - "SOURCE" selector **OFF**
 - "GENERATOR" selector **MAIN**
- 2 - ENGINE START panel
 - "IGNITION" switch **AUTO or OFF**
 The "IGNITION" switch is normally selected to AUTO. This ensures ignition, whenever the "STARTER" switch is set to ON.
 - "STARTER" switch **OFF**
 If not, starter is going to operate as soon as "SOURCE" selector is moved to BAT or GPU (if connected).
- 3 - EXT LIGHTS panel
 - All switches **OFF**
- 4 - GYRO INST panel
 - All switches **OFF**
- 5 - Breakers panel
 - All breakers **ENGAGED**
- 6 - DE ICE SYSTEM panel
 - All switches **OFF**
- 7 - Landing gear control **DN**



AMPLIFIED PROCEDURES

PREFLIGHT INSPECTION (Cont'd)

- 8 - Landing gear emergency control
Open door of emergency landing gear compartment.
 - Lever **PULLED DOWN**
 - By-pass selector **PUSHED**
 - Door **IN PLACE**
By-pass selector must be pushed at its maximum stop, so as to have the door in place.

- 9 - "AP / TRIMS MASTER" switch **OFF**

- 10 - "RADIO MASTER" switch **OFF**

- 11 - ECS panel
 - "BLEED" switch **OFF**
 - "AIR COND" switch **OFF**
 - "DUMP" switch **GUARDED**

- 12 - RAM AIR control **PUSHED**

- 13 - Fuel
 - "FUEL SEL" selector **MAN**
 - "AUX BP" switch **OFF**
 - Tank selector **L or R**

- 14 - ELT **ARM**

- 15 - Flight control lock **REMOVED / STOWED**
The flight control lock is normally stowed in the front cargo compartment with the towing bar and the blanking covers.

- 16 - Flight controls **Deflections checked**

- 17 - Parking brake **SET**

- 18 - Engine controls
 - "MAN OVRD" control **OFF (Notched)**



AMPLIFIED PROCEDURES

PREFLIGHT INSPECTION (Cont'd)

CAUTION

**WHEN THE ENGINE IS SHUTDOWN, THE POWER LEVER
MUST NOT BE MOVED BEHIND THE FLIGHT IDLE
POSITION**

When engine is shut-off, a lack of hydraulic pressure prevents movement into reverse range. Trying to force the mechanism will cause damage.

- Power lever **IDLE**
(Flight idle stop)
- Propeller governor lever **MAX. RPM**
- Condition lever **CUT OFF**

19 - Flaps control **UP**

20 - BAT BUS power supply

- Stop watch **CHECKED**
- Access lighting **CHECKED**
- Emergency lighting **CHECKED**

This check allows to ensure that the fuse of the "BAT BUS" operates correctly.

CAUTION

BEFORE SELECTING SOURCE, CHECK :

- 21 - "IGNITION" switch AUTO or OFF**
- 22 - "STARTER" switch OFF**
- 23 - Landing gear control DN**

24 - "SOURCE" selector **BAT or GPU**



AMPLIFIED PROCEDURES

PREFLIGHT INSPECTION (Cont'd)

- 25 - Voltage **CHECK**
 - BAT **> 25 Volts**
If not, use a GPU or charge battery. This minimum voltage is not an absolute guarantee for a correctly charged battery, particularly with a cadmium nickel technology. It is recommended to use a GPU in cold weather, when airplane has been stopped more than 3 hours at a temperature below - 10°C (+14°F).
 - GPU **≈ 28 Volts**
If using a GPU, ensure that it provides a 28-volt regulated voltage, with negative on earth, as well as it supplies 800 amperes minimum and 1400 amperes maximum. See placard located near ground power receptacle door.

- 26 - EXT LIGHTS panel
 - "LTS TEST" push button **PRESS**
(3 green lamps "L.LDG / TAXI / R.LDG" ON)
 - "L.LDG / TAXI / R.LDG" switches **ON**
(3 green lamps ON)
An outside inspection is not necessary ; the illuminated three green lamps located on switches prove the correct operation of the three landing lights.
 - "L.LDG / TAXI / R.LDG" switches **OFF**

- 27 - Fuel gages
 - Operation / quantity **CHECK**

- 28 - ADVISORY PANEL
 - Test 1 **ALL WARNING LIGHTS ON**
 - Test 2 **ALL WARNING LIGHTS ON**
"Test 1" and "2" correspond to BUS bars 1 or 2, which feed them respectively.



AMPLIFIED PROCEDURES

PREFLIGHT INSPECTION (Cont'd)

29 - Oxygen emergency

system **WARNING LIGHT**  **OFF**

If not, open isolation valve of the oxygen cylinder in R.H. karman. Oxygen emergency system in good operation condition must be imperatively taken on board during all flights, even at low altitude in order to be used in case of smoke in the cabin.

30 - INT LIGHTS panel **CHECK**

31 - ECS panel
- "LT TEST" push button **PRESS**
(amber indicator light ON)

32 - Flaps **LDG**

33 - Landing gear panel **Warning lights : 3 GREEN ON**
Test 1, then 2 : RED ON + 3 GREEN ON
"Test 1" and "2" correspond to BUS bars 1 or 2, which feed them respectively.

34 - "PITOT 1 HTR" switch **ON**
WARNING LIGHT  **OFF**

Correct operation of pitot (PITOT 1 and 2) tube heating elements and of stall aural warning system (STALL HTR) is indicated by extinction of corresponding lights on the advisory panel, when control switches are ON.



AMPLIFIED PROCEDURES

PREFLIGHT INSPECTION (Cont'd)

- 35 - "PITOT 2 & STALL HTR" switch **ON**
- | | | |
|-----------------------|------------------|------------|
| WARNING LIGHTS | PITOT 2 | OFF |
| | STALL HTR | |
- "PITOT 1 HTR" switch **OFF**
- "PITOT 2 & STALL HTR" switch **OFF**
- 36 - DE ICE SYSTEM panel
- "LTS TEST" push button **PRESS**
(All green lights ON)

WARNING

**DO NOT TOUCH PITOTS NOR STALL WARNING VANE.
THEY COULD BE HOT ENOUGH TO BURN SKIN**

- 37 - EXT LIGHTS panel
- "STROBE" **ON**
- "NAV" **ON**
- "ICE LIGHT" **ON**
- From outside the airplane, check operation of all lights and the stall warning horn*
- 38 - Reentering the airplane
- EXT LIGHTS panel **ALL SWITCHES OFF**
- DE ICE SYSTEM panel **ALL SWITCHES OFF**
- 39 - "SOURCE" selector **OFF**



AMPLIFIED PROCEDURES

PREFLIGHT INSPECTION (Cont'd)

Cabin (II)

- 1 - Cabin fire extinguisher **CHECK**
(Pressure / Attachment)
The fire extinguisher is provided with a pressure gage.
- 2 - Seats / belts **CHECK**
- 3 - Windows **CHECK**
(General condition / No cracks)
- 4 - Emergency exit **CLOSED / LOCKED**
- Anti-theft safety **REMOVE / STOW**
- 5 - Baggage compartment **STRAPS IN PLACE**
- 6 - Partition net **IN PLACE**
- 7 - Doors operation **CHECK**
- 8 - Stairs condition **CHECK**
(Condition / Play)



AMPLIFIED PROCEDURES

PREFLIGHT INSPECTION (Cont'd)

B - AIRPLANE OUTSIDE

The preflight inspection described in Figure 4.3.1 is recommended before each flight.

NOTE :

If a preflight inspection is performed, just after the engine shut-off, be careful because the leading edge of engine air inlet, as well as exhaust stubs may be very hot.

If the airplane was in long term storage or if it has undergone major maintenance or if it has been used from emergency airfields, a thorough outside inspection is recommended.

When the airplane is stored outside, the use of the flight control lock and blanking covers is recommended. Propeller should be tied down to prevent rotation without oil pressure.

When the airplane is stored for extended periods of time, a thorough preflight inspection is recommended. Particular attention should be paid to possible blockages in airspeed sensing lines, foreign objects in engine intake and exhaust stubs and water contamination of the fuel system.

L.H. wing (III)

- 1 - Flap **CHECK (Condition / Play)**

Also inspect the lower surface, as well as flap fairing, where pebbles (and even ice in case of slush on the runway) may have accumulated.

- 2 - Aileron and trim / Spoiler **CHECK (Condition / Free movement / Deflection)**

Ensure there are no foreign objects in the spoiler recess. When ailerons are in the neutral position, it is normal that spoilers are lightly extended at upper surface.



AMPLIFIED PROCEDURES

PREFLIGHT INSPECTION (Cont'd)

- 3 - Trailing edge static discharger **CHECK**
(Condition / Attachment)
- 4 - Wing tip / nav. lights /
Strobe / landing light **Condition - CHECK**
- 5 - OAT probe **Condition - CHECK**
- 6 - Fuel tank **CAP CLOSED / LOCKED**
Fuel tank caps must be tight (which is characterized by a consequent exertion to lock and unlock them) to avoid water infiltration in case of rain on ground, and to avoid fuel loss in flight.
- 7 - Fuel tank air vent **UNOBSTRUCTED - CHECK**
Air vent is not likely to be obstructed by ice or water, as it is located in a wing lower surface recess.
- 8 - External pitot (IAS) **Condition - CHECK**
- 9 - Internal pitot (V_{MO}) **Condition - CHECK**
- 10 - Wing lower surface **CHECK**
- Check fuel tank access doors for leaks
- Check for surface damage.
- 11 - Wing deicer boots **CHECK**
(Condition / Attachment)
Care must be taken when refuelling the airplane to avoid damaging the wing deicer boots. A protective apron should be used if possible.



AMPLIFIED PROCEDURES

PREFLIGHT INSPECTION (Cont'd)

12 - Fuel tank drain (two on each wing) **DRAIN**
(Fuel free of water and contamination)

In case of water in fuel system, drain it carefully using the four drain valves of tank sumps, and the fuel filter drain valve, till every trace of water or deposit has disappeared.

A long term storage of the airplane causes water accumulation in fuel, which absorbs additive. This phenomenon occurs when an excessive quantity of water accumulates in fuel tank sumps. Refer to Section 8 for servicing operations relative to fuel additives.

13 - L.H. main landing gear

- Shock absorber / doors /
tire / wheel well **CHECK**

If airplane has been used from muddy airfields or in snow, check wheel wells to make sure they are clean and not obstructed.

Check frequently all landing gear retraction mechanism components, shock-absorbers, tires and brakes. This is particularly important for airplanes used from hilly fields.

Improperly serviced or worn shock-absorbers may result in excessive loads being transmitted to the airplane structure during ground operations. Without passengers and baggages on board, the unpainted surface of the main gear shock absorber tube must be visible about :

- . 55 mm (2.17 in) of minimum height with half tank (140 us gal),
- . 40 mm (1.57 in) of minimum height with full tanks (280 us gal).



AMPLIFIED PROCEDURES

PREFLIGHT INSPECTION (Cont'd)

Fuselage forward section (IV)

- 1 - Forward compartment
 - Inside **CONTROLLED**
 - Door **CLOSED / LOCKED**
- 2 - GPU door **CLOSED**
 (If not used)
- 3 - Fuel circuit drain **DRAIN**
 (Fuel free of water and contamination)
 - Filter contamination indicator **CHECK**

**Open the inspection door located on
 L.H. side under front baggage compartment**
- 4 - L.H. exhaust stub **CHECK**
 (Condition / No crack)
 Inspect if possible pressure port located inside exhaust stub. A missing port or a cracked port may hinder correct operation of continuous heating of air inlet lip.
- 5 - Upper engine cowls **OPEN**
 For the first flight of the day :
 - Oil cap **CLOSED / LOCKED**
 - Engine oil level **CHECK**
 - Fuel pipes **CHECK**

(No leak, deterioration, wear)
- 6 - Engine cowls **Condition - CHECK**
CLOSED / LOCKED



AMPLIFIED PROCEDURES

PREFLIGHT INSPECTION (Cont'd)

7 - Air inlets

- Main **No crack - UNOBSTRUCTED**
Check for no cracks, which are sometimes put in evidence by traces of soot resulting from exhaust gases.
- Lateral / upper **UNOBSTRUCTED**
Lateral air inlets, which supply air conditioning system and oil cooler, are provided with blanking covers. It is not the case for upper air inlets of RAM AIR system (circular grille located in front of R.H. windshield) and of vapor cycle cooling system (two rectangular grilles located forward of the circular grille).

8 - Propeller and spinner **CHECK**
(No nicks, cracks or oil leaks / Attachment)

In case of operation from contaminated runways, it is necessary to carefully examine propeller blades, where traces of abrasion may be found. Propeller damage may reduce blade life time and degrade performance. Any propeller damage should be referred to maintenance personnel.

9 - Nose gear

- Landing light / shock absorber / doors /
tire / wheel well **CHECK**

Without passengers and baggages on board, the unpainted surface of the nose gear shock absorber tube must be visible about :

- 57 mm (2.22 in) of minimum height with full tanks,
- 63 mm (2.46 in) of minimum height with half tank.

NOTE :

Crush or relieve the shock absorber one time or twice before the inspection to remove possible sticking.

In case of doubt, request a check of the shock absorber pressure.

10 - R.H. exhaust stub **CHECK**
(Condition / No cracks)



AMPLIFIED PROCEDURES

PREFLIGHT INSPECTION (Cont'd)

R.H. wing (V)

Additional remarks are identical to those of L.H. wing.

- 1 - Fuel tank drain (two on each wing) **DRAIN**
(Fuel free of water and contamination)
- 2 - Main landing gear
- Shock absorber / doors /
tire / wheel well **CHECK**
- 3 - Wing deicer boots **CHECK**
(Condition / Attachment)
- 4 - Stall warning **CHECK**
(Condition / Deflection)
- 5 - Wing lower surface **CHECK**
(No leaks)
- 6 - Fuel tank **CAP CLOSED / LOCKED**
- 7 - Fuel tank air vent **Unobstructed - CHECK**
- 8 - Wing tip / nav. light /
strobe / landing light **Condition - CHECK**
- 9 - Trailing edge static discharger **CHECK**
(Condition / Number / Attachment)
- 10 - Aileron / spoiler **CHECK**
(Condition / Free movement / Deflection)
- 11 - Flap **CHECK**
(Condition / Play)
- 12 - Rear R.H. karman **Oxygen cylinder open**
- 13 - Oxygen pressure **CHECK**



AMPLIFIED PROCEDURES

PREFLIGHT INSPECTION (Cont'd)

Fuselage rear section / Empennages (VI)

Check that outside handle of emergency exit is flush with door skin.

- 1 - ELT **OFF**
Access to ELT is possible through an inspection door located on R.H. side of fuselage rear section.
- 2 - Static pressure ports **Clean - CHECK**
- 3 - Ventral fins **CHECK**
(Attachment condition)
Ventral fins are made of two parts (one fixed part and one removable part with rear lower inspection door). Check that these two parts are connected by the locking roller.
- 4 - Inspection door under fuselage **CLOSED - CHECK**
(Attachments)
- 5 - Horizontal stabilizer
deicer boots (R.H. side) **CHECK**
(Condition / Attachments)
- 6 - Elevator and trim **CHECK**
(Condition / Deflection free movement / Trim position)
To check the deflection, hold the two half-elevators near fuselage, inside both elevator trims to avoid stresses.
- 7 - Static dischargers **CHECK**
(Condition)
- 8 - Vertical stabilizer deicer boots **CHECK**
(Condition / Attachments)
- 9 - Rudder and trim **CHECK**
(Condition / Trim position)



AMPLIFIED PROCEDURES

PREFLIGHT INSPECTION (Cont'd)

- 10 - Static dischargers **CHECK
(Condition)**
- 11 - Tail cone **Condition - CHECK**
- 12 - Static pressure ports **Clean - CHECK**
- 13 - Rear baggage compartment
 - Inside **CONTROLLED**
 - Door **CLOSED / LOCKED**

AMPLIFIED PROCEDURES

BEFORE STARTING ENGINE (1/5)
(Refer to Supplement 41 for TBM 700C2 airplane)

Check that the weight and balance are within the correct limits. Brief passengers about use of seat belts and the emergency oxygen system, as well as opening the access door and the emergency exit.

CAUTION

"BLEED" SWITCH ON "ON" MAY CAUSE OVERTEMPERATURE OR ABNORMAL ACCELERATION AT START

CAUTION

MAKE SURE THAT "MAN OVRD" CONTROL IS "OFF" TO AVOID OVERTEMPERATURE RISKS AT START

- 1 - Preflight inspection **COMPLETED**
- 2 - Cabin access door **CLOSED / LOCKED**
- 3 - "Pilot" door (if installed) **CLOSED / LOCKED**
- 4 - Baggage **STOWED**
- 5 - Parking brake **SET**
"PARK BRAKE" warning light located on advisory panel does not indicate that parking brake is set. For that, press on brake pedals before turning parking brake selector to the right.
- 6 - Weight and balance **COMPUTED / CHECKED**
- 7 - Seats
 - Pilot **ADJUSTED**
 - R.H. front station **If not occupied by a second pilot :
adjust seat so as not to hinder
full travel of flight controls**



AMPLIFIED PROCEDURES

BEFORE STARTING ENGINE (2/5)

If the airplane is equipped with option OPT70 01029 "Provision for TBM 700C2" :

- Pilot seat and R.H. front seat (if occupied)
 - . Height adjustment **Maximum UP**
 - . Fore and aft adjustment . **ADJUST and CHECK LOCKING**
 - . Height adjustment **ADJUST**

CAUTION

IT IS MANDATORY TO ADJUST SEAT IN FORE-AFT MOVEMENT WHEN SEAT IS IN MAXIMUM HIGH PERMISSIBLE POSITION, TO AVOID INTERFERENCE BETWEEN SIDE UPHOLSTERY PANEL AND SEAT HOUSING IN LOW AND INTERMEDIATE POSITIONS

Adjust pilot's and R.H. front station seats and harnesses, so as to permit access to all flight controls. The pilot at L.H. station must be able to easily reach ECS panel.

- 8 - R.H and L.H. pedals **ADJUSTED**
- 9 - Belts and harnesses (Pilot and passengers) **FASTENED**
Check belt buckles for correct locking, as well as automatic locking of shoulder harness by exerting a rapid pull on the latter.
- 10 - Crash lever **UP**
- 11 - Oxygen supply **Available for the planned flight**
(see tables of paragraph "IN-FLIGHT AVAILABLE OXYGEN QUANTITY" and Chapter 7.10 for a FAR 135 type operation)
- 12 - "OXYGEN" switch **ON**
- 13 - "PASSENGERS OXYGEN" switch **OFF**
- 14 - Copilot and pilot masks **Press push-button "PRESS TO TEST" : the blinker shall turn red momentarily, then turns transparent**



AMPLIFIED PROCEDURES

BEFORE STARTING ENGINE (3/5)

- 15 - "NORMAL/MASK" micro inverter **NORMAL**
- 16 - "IGNITION" switch **AUTO or OFF**
The "IGNITION" switch is normally selected to AUTO. This ensures ignition, whenever the starter is activated.
- 17 - "STARTER" switch **OFF**
If not, starter is going to operate as soon as "SOURCE" selector is positioned on BAT or GPU in case of supplying by GPU.
- 18 - Landing gear control **DN**
- 19 - "RADIO MASTER" switch **ON**
- 20 - RADIO VHF1 **ON / ADJUSTED**
An electric relay automatically cuts off radio equipment during starter operation.
The function "GND CLR" (ground clearance) enables, when "RADIO MASTER" switch is ON, to obtain VHF1 supply without having selected battery contact.
- 21 - Authorization for engine starting **ASKED**
- 22 - ETM
 - Fuel remaining **Check**
 - Added fuel **Insert**
 - Fuel flow page **Select**The "SHADIN" ETM operation normal procedures are described in the Operation Manual, at the latest revision.
- 23 - "SOURCE" selector **BAT (or GPU)**
- 24 - "BAT TEMP TEST" push-button
(if installed - with a Cadmium-Nickel battery) **PRESS**
Check illumination of the "BAT OVHT" warning light on the advisory panel, check increase of the temperature indicated on the battery temperature indicator.
- 25 - Passengers briefing **AS REQUIRED**



AMPLIFIED PROCEDURES

BEFORE STARTING ENGINE (4/5)

26 - Access door and

(if installed) "pilot" door **WARNING LIGHT**

DOOR

OFF

If "DOOR" warning light is not OFF, open the access door and (if installed) the "pilot" door and reclose it (them). Check locking pins are in place (green band is visible). Do not take off with "DOOR" warning light ON on the advisory panel.

27 - Fuel

- Gages **CHECKED**
- Tank selector **L or R - CHECKED**
- "FUEL SEL" switch **AUTO**

WARNING LIGHT

AUTO SEL

OFF

- "SHIFT" push-button **PRESS**

**The selector changes tank
On ground, observe a tank change
every minute and 15 seconds**

28 - ETM fuel flowmeter totalizer **CHECKED - ADJUSTED**

Total fuel quantity on board may be set on flowmeter totalizer - see instructions in Section 7 or refer to manufacturer technical data.

29 - Engine instruments **CHECK**

30 - ITT TEST **CARRY OUT**

Check 1888 number appearance in digital readout window, as well as ITT red warning light illumination on advisory panel.

31 - EXT LIGHTS panel

- "STROBE" **AS REQUIRED**

The use of strobe lights may generate discomfort to personnel on ground, particularly by night.



AMPLIFIED PROCEDURES

BEFORE STARTING ENGINE (5/5)

32 - In case of night flight

- INT LIGHTS panel : "INSTR" + "PANEL" **ADJUSTED**
- Navigation lights **ON**
- Flashlight (if necessary) **IN PLACE**

To maintain battery power for starting, and only when "GND CLR" (ground clearance) is available on airplane, VHF1 can be operated by setting "SOURCE" selector to OFF and "RADIO MASTER" switch to ON. A correct operation is provided by the "GND CLR" green light illuminating above the "RADIO MASTER" switch. If battery voltage is low (near 25 volts), turn off all unessential electrical equipment before selecting the starter ON. By night, emergency lighting, provided by two luminous spot lights located above front seats, is sufficient to illuminate crew documents and instrument panel.

AMPLIFIED PROCEDURES

**STARTING ENGINE USING AIRPLANE POWER
(1/6)**

CAUTION

BEFORE SELECTING SOURCE, CHECK :

- 1 - "IGNITION" switch **AUTO or OFF**
- 2 - "STARTER" switch **OFF**
- 3 - "INERT SEP" switch **OFF**
- 4 - Landing gear control **DN**

- 5 - ELECTRIC POWER panel
 - "SOURCE" selector **BAT**
 - Mains voltage **CHECKED**
> 25 Volts

- 6 - Engine controls
 - "MAN OVRD" control **OFF (Notched)**

CAUTION

**WHEN THE ENGINE IS SHUTDOWN, THE POWER LEVER
MUST NOT BE MOVED BEHIND THE FLIGHT IDLE
POSITION**

- Power lever **IDLE**
(Flight idle stop)
- Propeller governor lever **MAX. RPM**
- Condition lever **CUT OFF**

- 7 - FUEL panel
 - "AUX BP" switch **ON**

WARNING LIGHT	AUX BP ON	ON
---------------	-----------	----

WARNING LIGHT	FUEL PRESS	OFF
---------------	------------	-----

- Fuel pressure indicator **Green sector**



AMPLIFIED PROCEDURES

**STARTING ENGINE USING
AIRPLANE POWER (2/6)**

- 8 - Propeller **AREA CLEAR**
- 9 - ENGINE START panel
 - "IGNITION" switch **AUTO**
 - "STARTER" switch **ON**



NOTE :

The utilization of the starter is bound by limitations mentioned in Chapter 2.4 "STARTER OPERATION LIMITS".

Ng \simeq 13 %

- Condition lever **LO / IDLE**
When condition lever is positioned on LO / IDLE before having obtained 13 % of Ng, there is a risk of overtemperature further to an excessive accumulation of fuel inside the combustion chamber before ignition.

Monitor increase of :

- ITT **(max. ITT : 870°C for 20 seconds max.
1000°C for 5 seconds max.)**

The absolute limit read on the indicator is 1090°C during the starting sequence (red triangle). However, the ITT limits during the starting sequence are :

- . 870°C for 20 seconds max.
- . 1000°C for 5 seconds max.

In case of starting with hot engine, an ITT decrease comprised between 150°C and 170°C (within starter operation limits), before opening of the condition lever, may allow to stay within above mentioned ITT limits.



AMPLIFIED PROCEDURES

**STARTING ENGINE USING
AIRPLANE POWER (3/6)**

In case of higher temperature and longer time, stop immediately the starting procedure as indicated in the following caution and inform the maintenance department.

If starting engine procedure is aborted further to overtemperature indications (max. ITT : 870°C for more than 20 seconds - 1000°C for more than 5 seconds), maintaining during few seconds "STARTER" switch ON (within starter operating limits) may reduce max. ITT obtained by ventilating combustion chamber.

NOTE :

No action is required for the following conditions :

ITT : from 800 °C to 870 °C limited to 20 seconds,

from 870 °C to 1000 °C limited to 5 seconds.

CAUTION

IF 10 SECONDS AFTER HAVING POSITIONED CONDITION LEVER TO "LO / IDLE" THERE IS NO IGNITION OR IF DURING IGNITION SEQUENCE, OVERTEMPERATURE INDICATION APPEARS (MAX. ITT : 870°C FOR MORE THAN 20 SECONDS - 1000°C FOR MORE THAN 5 SECONDS),

INTERRUPT STARTING PROCEDURE :

Condition lever CUT OFF

"IGNITION" switch OFF (or AUTO)



AMPLIFIED PROCEDURES

**STARTING ENGINE USING
AIRPLANE POWER (4/6)**

Wait ITT < 800°C, then :

"STARTER" switch OFF

**BEFORE ANY RESTARTING ATTEMPT, CARRY OUT A
MOTORING**

(Refer to paragraph "MOTORING")

CONTINUE WITH NORMAL PROCEDURE HEREAFTER

- Ng

The start sequence must be timed to ensure starter limits are not exceeded. Lengthy operation of the starter results in excessive temperature of the engine :

- If Ng does not reach 30 % within 30 seconds, after the starter is selected ON, abort the start.

- If Ng does not reach 50 % within 1 minute, abort the start.

- Before starting a new test, respect delays indicated in Chapter 2.4 "STARTER OPERATION LIMITS".

- Oil pressure WARNING LIGHT



OFF

CAUTION

IF ENGINE STAGNATES,

INTERRUPT STARTING PROCEDURE :

Condition lever CUT OFF

"IGNITION" switch OFF (or AUTO)

"STARTER" switch OFF

**WAIT FOR 1 MINUTE (Refer to Chapter 2.4 "STARTER
OPERATION LIMITS"), THEN TRY TO RESTART**



AMPLIFIED PROCEDURES

STARTING ENGINE USING
AIRPLANE POWER (5/6)

ENGINE START panel

- "IGNITION" switch AUTO
- "STARTER" switch ON

WARNING LIGHTS

STARTER

FLASHING

IGNITION

ON

Ng ≈ 13 %

- Condition lever HI / IDLE

Monitor increase of :

- ITT (max. ITT : 870°C for 20 seconds max.
1000°C for 5 seconds max.)

- Ng

- Oil pressure WARNING LIGHT

OIL PRESS

OFF

Ng ≈ 50 %

- "STARTER" switch OFF

WARNING LIGHTS

STARTER

OFF

IGNITION



AMPLIFIED PROCEDURES

**STARTING ENGINE USING
 AIRPLANE POWER (6/6)**

■ Engine instruments **CHECK Ng increasing to 68 % (± 1 %)**
 (Oil pressure / ITT = green sector)

NOTE :

This behaviour should only be observed with outside low temperature (IOAT < 0 °C), cold engine.

This procedure may be used for the first starting of the day.

CONTINUE WITH NORMAL PROCEDURE HEREAFTER

10 - "STARTER" switch **OFF**
 Check Ng > 52 %

11 - Condition lever **HI / IDLE**

■ 12 - Engine instruments **CHECK : Ng ≈ 68 % (± 1 %)**
 (Oil pressure / Oil temperature / ITT = green sector)

13 - FUEL panel
 - "AUX BP" switch **AUTO**
 At this time, observing a drop in the fuel pressure is normal.

	WARNING LIGHT	<div style="border: 1px dashed black; padding: 2px; display: inline-block;">AUX BP ON</div>	OFF
--	----------------------	---	------------

14 - Generator	WARNING LIGHT	<div style="border: 1px dashed black; padding: 2px; display: inline-block;">MAIN GEN</div>	OFF
--------------------------	----------------------	--	------------

RESET if necessary

"MAIN GEN" warning light normally goes out, as soon as "STARTER" warning light goes out.

If not, increase Ng over 70 % to start main generator.

- Battery ammeter	CHARGE CHECKED
- Battery voltage	CHECKED
	(V ≈ 28 Volts)

AMPLIFIED PROCEDURES

**STARTING ENGINE USING
EXTERNAL POWER (GPU) (1/7)**

Before connecting GPU, check that its indicated voltage is correct.

1 - GPU **CONNECTED**

CAUTION

BEFORE SELECTING SOURCE, CHECK :

- 2 - "IGNITION" switch **AUTO or OFF**
- 3 - "STARTER" switch **OFF**
- 4 - "INERT SEP" switch **OFF**
- 5 - Landing gear control **DN**

6 - "SOURCE" selector **GPU**

WARNING LIGHT



ON

WARNING LIGHT



ON

- Voltmeter **VOLTAGE CHECKED**
(V ≈ 28 Volts)

If voltage is ≥ 30 volts, immediately turn "SOURCE" selector to OFF. Radio navigation equipment may be damaged before main fuse failure.

7 - Engine controls

- "MAN OVRD" control **OFF (Notched)**

CAUTION

**WHEN THE ENGINE IS SHUTDOWN, THE POWER LEVER
MUST NOT BE MOVED BEHIND THE FLIGHT IDLE
POSITION**

- Power lever **IDLE**
(Flight idle stop)

- Propeller governor lever **MAX RPM**

- Condition lever **CUT OFF**



AMPLIFIED PROCEDURES

**STARTING ENGINE USING
 EXTERNAL POWER (GPU) (2/7)**

- 8 - FUEL panel
 - "AUX BP" switch **ON**

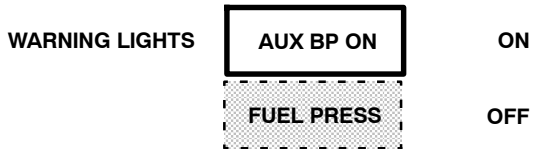

- Fuel pressure indicator **CHECK**

- 9 - Propeller **AREA CLEAR**

- 10 - ENGINE START panel
 - "IGNITION" switch **AUTO**
 - "STARTER" switch **ON**

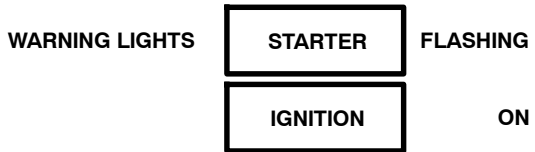

NOTE :
The use of the starter is limited. Refer to Chapter 2.4 "STARTER OPERATION LIMITS".

- Ng \simeq 13 %
 - Condition lever **LO / IDLE**

When condition lever is positioned on LO / IDLE before having obtained 13 % of Ng, there is a risk of overtemperature further to an excessive accumulation of fuel inside the combustion chamber before ignition.

Avoid staying at or above 13 %, Ng is usually stabilized after leaving starter ON during 10 seconds.



AMPLIFIED PROCEDURES

**STARTING ENGINE USING
EXTERNAL POWER (GPU) (3/7)**

Monitor increase of :

- ITT (**max. ITT : 870°C for 20 seconds max.
1000°C for 5 seconds max.**)

The absolute limit read on the indicator is 1090°C during the starting sequence (red triangle). However, the ITT limits during the starting sequence are :

- . 870°C for 20 seconds max.
- . 1000°C for 5 seconds max.

In case of starting with hot engine, an ITT decrease comprised between 150°C and 170°C (within starter operation limits), before opening of the condition lever, may allow to stay within above mentioned ITT limits.

In case of higher temperature and longer time, stop immediately the starting procedure as indicated in the following caution and inform the maintenance department.

This starting engine procedure must be also applied in case of drop in voltage supplied by GPU. This drop will be shown by a low or zero Ng acceleration.

If starting engine procedure is aborted further to overtemperature indications (max. ITT : 870°C for more than 20 seconds – 1000°C for more than 5 seconds), maintaining during few seconds "STARTER" switch ON (within starter operating limits) may reduce max. ITT obtained by ventilating combustion chamber.

NOTE :

No action is required for the following conditions :

- ITT from 800 °C to 870 °C limited to 20 seconds,
- ITT from 870 °C to 1000 °C limited to 5 seconds.



AMPLIFIED PROCEDURES

**STARTING ENGINE USING
EXTERNAL POWER (GPU) (4/7)**

CAUTION

IF 10 SECONDS AFTER HAVING POSITIONED CONDITION LEVER TO "LO / IDLE" THERE IS NO IGNITION OR IF DURING IGNITION SEQUENCE, OVERTEMPERATURE INDICATION APPEARS (MAX. ITT : 870°C FOR MORE THAN 20 SECONDS - 1000°C FOR MORE THAN 5 SECONDS),

INTERRUPT STARTING PROCEDURE :

Condition lever CUT OFF

"IGNITION" switch OFF (or AUTO)

Wait ITT < 800°C, then :

"STARTER" switch OFF

**BEFORE ANY RESTARTING ATTEMPT, CARRY OUT A
MOTORING
(Refer to paragraph "MOTORING")**

CONTINUE WITH NORMAL PROCEDURE HEREAFTER

- Ng
The start sequence must be timed to ensure starter limits are not exceeded. Lengthy operation of the starter results in excessive temperature of the engine :
 - If Ng does not reach 30 % within 30 seconds, after the starter is selected ON, abort the start.
 - If Ng does not reach 50 % within 1 minute, abort the start.
 - Before starting a new test, respect delays indicated in Chapter 2.4 "STARTER OPERATION LIMITS".

- Oil pressure **WARNING LIGHT** OIL PRESS **OFF**



AMPLIFIED PROCEDURES

STARTING ENGINE USING EXTERNAL POWER (GPU) (5/7)

CAUTION

IF ENGINE STAGNATES,

INTERRUPT STARTING PROCEDURE :

Condition lever CUT OFF

"IGNITION" switch OFF (or AUTO)

"STARTER" switch OFF

WAIT FOR 1 MINUTE (Refer to Chapter 2.4 "STARTER OPERATION LIMITS"), THEN TRY TO RESTART

ENGINE START panel

- "IGNITION" switch AUTO

- "STARTER" switch ON

WARNING LIGHTS

STARTER

FLASHING

IGNITION

ON

Ng \simeq 13 %

- Condition lever HI / IDLE

Monitor increase of :

- ITT (max. ITT : 870°C for 20 seconds max.
 1000°C for 5 seconds max.)

- Ng

- Oil pressure WARNING LIGHT

OIL PRESS

OFF



AMPLIFIED PROCEDURES

**STARTING ENGINE USING
 EXTERNAL POWER (GPU) (6/7)**

Ng \approx 50 %

- "STARTER" switch **OFF**

WARNING LIGHTS

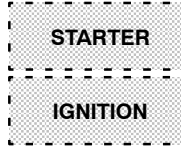

OFF

Engine instruments **CHECK Ng increasing to 68 % (\pm 1 %)**
(Oil pressure / ITT = green sector)

NOTE :

This behaviour should only be observed with outside low temperature (IOAT < 0 °C), cold engine.

This procedure may be used for the first starting of the day.

CONTINUE WITH NORMAL PROCEDURE HEREAFTER

11 - "SOURCE" selector **BAT**

WARNING LIGHT



OFF

12 - Propeller governor lever **FEATHER**

This reduces propeller blast on the person disconnecting the GPU.

13 - GPU **HAVE IT DISCONNECTED**

WARNING LIGHT



OFF

This means that ground power receptacle door has been correctly locked.

14 - Condition lever **HI / IDLE**

15 - Propeller governor lever **MAX. RPM**



AMPLIFIED PROCEDURES

STARTING ENGINE USING EXTERNAL POWER (GPU) (7/7)

■ 16 - Engine instruments **CHECK : Ng \simeq 68 % (\pm 1 %)**
(Oil pressure / Oil temperature / ITT = green sector)

17 - FUEL panel
- "AUX BP" switch **AUTO**
At this time, observing a drop in the fuel pressure is normal.

WARNING LIGHT	AUX BP ON	OFF
---------------	------------------	-----

18 - Generator **WARNING LIGHT**

	MAIN GEN	OFF
--	-----------------	-----

RESET if necessary

"MAIN GEN" warning light normally goes out, as soon as "STARTER" warning light goes out.

If not, increase Ng over 70 % to start main generator.

- Battery ammeter **CHARGE CHECKED**
- Battery voltage **CHECKED**
(V \simeq 28 Volts)

AMPLIFIED PROCEDURES

MOTORING (1/3)

To drain fuel accumulated inside the combustion chamber, a motoring procedure is required following an aborted start.

A 15-second dry motoring run is sufficient to clear any fuel pooled in the engine. The fuel is removed in liquid or vapor form, through an airflow intended to dry combustion chamber, turbines and exhaust nozzles.

To improve cooling of the bearing cavities and prevent oil coking after shut-down in high OAT [above 35°C (95°F)] environment, it is recommended to perform a 30-second dry motoring run.

It is possible that no trace of drainage be observed under engine, due to the drainage collector intended to prevent parking area from contamination.

CAUTION

AFTER ANY STARTING INTERRUPT PROCEDURE :

- **WAIT FOR ENGINE TOTAL SHUT-DOWN**
- **WAIT AT LEAST 30 SECONDS BEFORE INITIATING A MOTORING**

- 1 - Engine controls
 - "MAN OVRD" control **OFF (Notched)**

CAUTION

**WHEN THE ENGINE IS SHUTDOWN, THE POWER LEVER
MUST NOT BE MOVED BEHIND THE FLIGHT IDLE
POSITION**

- Power lever **IDLE
(Flight idle stop)**
- Propeller governor lever **MAX RPM**
- Condition lever **CUT OFF**



AMPLIFIED PROCEDURES

MOTORING (2/3)

- 2 - FUEL panel
 - Tank selector L or R
 - "AUX BP" switch ON

WARNING LIGHTS	AUX BP ON	ON
	FUEL PRESS	OFF

Fuel pressure is necessary for lubrication of HP pump.

- 3 - "IGNITION" switch OFF

WARNING LIGHT	IGNITION	OFF
---------------	----------	-----

To clear fuel and vapor internally trapped :

- 4 - "STARTER" switch ON
 for 15 sec maxi

WARNING LIGHT	STARTER	FLASHING
---------------	----------------	----------

To cool engine following shut-down in high temperature environment :

- 4 - "STARTER" switch ON
 during 30 sec

WARNING LIGHT	STARTER	FLASHING
---------------	----------------	----------

If ignition symptoms occur (ITT increasing), check that "IGNITION" switch is OFF, that condition lever is on CUT OFF and continue motoring.

- 5 - "STARTER" switch OFF

WARNING LIGHT	STARTER	OFF
---------------	---------	-----



AMPLIFIED PROCEDURES

MOTORING (3/3)

6 - FUEL panel
- "AUX BP" switch OFF

WARNING LIGHTS	AUX BP ON	OFF
	FUEL PRESS	ON

AMPLIFIED PROCEDURES

**MOTORING FOLLOWED BY
AN ENGINE START (1/3)**

Amplified procedures stated in starting engine sequences using airplane power or with GPU are also to be applied to hereunder procedure.

Within starter operating limits (continuous max. 1 minute), it is possible to initiate a starting procedure from a motoring procedure.

This procedure will conserve the battery by taking advantage of first Ng acceleration.

- 1 - Engine controls
 - "MAN OVRD" control **OFF (Notched)**

CAUTION

**WHEN THE ENGINE IS SHUTDOWN, THE POWER LEVER
MUST NOT BE MOVED BEHIND THE FLIGHT IDLE
POSITION**

- Power lever **IDLE
(Flight idle stop)**
- Propeller governor lever **MAX. RPM**
- Condition lever **CUT OFF**

- 2 - Fuel
 - Tank selector **L or R**
 - "AUX BP" switch **ON**

WARNING LIGHTS

AUX BP ON

ON

FUEL PRESS

OFF

- 3 - "IGNITION" switch **OFF**
- 4 - "STARTER" switch **ON during 15 sec**



AMPLIFIED PROCEDURES

**MOTURING FOLLOWED BY
 AN ENGINE START (2/3)**

- 5 - After 15 seconds :
 - "IGNITION" switch **AUTO**
 - Ng **Check at 13 % minimum**
 - Condition lever **LO / IDLE**

- 6 - Monitor increase of :
 - ITT **(max. ITT : 870°C for 20 seconds max.
 1000°C for 5 seconds max.)**

- Ng
- oil pressure **WARNING LIGHT** OIL PRESS **OFF**

NOTE :

No action is required for the following conditions :

- *ITT from 800°C to 870°C limited to 20 seconds,*
- *ITT from 870°C to 1000°C limited to 5 seconds.*

Ng \simeq 50 % stable

- "STARTER" switch **OFF**

	WARNING LIGHTS	STARTER	OFF
		IGNITION	

- 7 - Engine instruments **CHECK : Ng > 52 %
 (Oil pressure / ITT = green sector)**

- 8 - Condition lever **HI / IDLE**

- 9 - Engine instruments **CHECK : Ng \simeq 68 % (\pm 1 %)
 (Oil pressure / Oil temperature / ITT = green sector)**



AMPLIFIED PROCEDURES

MOTORING FOLLOWED BY AN ENGINE START (3/3)

- 10 - FUEL panel
 - "AUX BP" switch **AUTO**
 - WARNING LIGHT** AUX BP ON **OFF**

 - 11 - Generator **WARNING LIGHT** MAIN GEN **OFF**
- Battery ammeter **RESET if necessary**
 - Battery voltage **CHARGE CHECKED**
 - CHECKED**
 - (V ≈ 28 Volts)**

AMPLIFIED PROCEDURES

AFTER STARTING ENGINE (1/4)

1 - GYRO INST panel
 - All switches **ON**
 Pull on the caging knobs when starting the ADI(s).

2 - Gyroscopic suction gage indicator **GREEN SECTOR**
WARNING LIGHT VACUUM LO OFF

3 - GYRO SLAVING selector **SLAVE**

4 - DE ICE SYSTEM panel
 Flight into known icing conditions is authorized only when all ice protection equipment are operating correctly. This equipment may be activated before takeoff, even during taxiing, in case of icing conditions on ground. Refer to Chapter 4.5 "PARTICULAR PROCEDURES" of this Section.

- "PROP DE ICE" switch **ON**
Check illumination of the green light located above the switch

Illumination of the green light shows that power supplied to blade root electric resistors is between 8 and 10 amperes. It is advised to wait at least a whole half cycle (90 seconds) to check that both blade pairs are correctly deiced.

- "PROP DE ICE" switch **OFF**
 - "L.WINDSHIELD" switch **ON**



AMPLIFIED PROCEDURES

AFTER STARTING ENGINE (2/4)

- "R.WINDSHIELD" switch **ON**
Check illumination of the green light located above the switch (except if hot conditions)

This light may remain OFF, if cabin temperature is very high, for example after a prolonged parking in hot conditions (see Chapter 7.13 for operational principle).

- "L.WINDSHIELD" switch **OFF**
- "R.WINDSHIELD" switch **OFF**

Increase power so as to get Ng ≥ 80% to check AIRFRAME DE ICE

Theoretically, necessary air bleed to inflate wing and empennage leading edges, as well as depression necessary to their deflation are sufficient when power lever is positioned on IDLE. However, it is advised for check to choose a Ng power ≥ 80 % in order to obtain operation design pressure, which enables illuminating surely the two green lights and avoiding "VACUUM LO" untimely alarms.

- "AIRFRAME DE ICE" switch **ON**
Visually check functioning of deicer boot during 1 total cycle and illumination of the two green lights located above the switch

The cycle lasts 67 seconds. Check both inflation impulses, and illumination of each corresponding green light :

- the first impulse inflates the external and middle wing boots,
- the second impulse inflates the leading edge boots of empennages and inner wing.

- "AIRFRAME DE ICE" switch **OFF**
- "INERT SEP" switch **ON**

WARNING LIGHT	INERT SEP	ON
		after 30 seconds

"INERT SEP" switch is kept on while taxiing in order to avoid ingestion of particles by the engine.



AMPLIFIED PROCEDURES

AFTER STARTING ENGINE (3/4)

5 - "GENERATOR" selector

For these tests, "BLEED" switch must be left OFF, to unload the generator circuit.

- On "MAIN" **Voltage and current checked**

when current \leq 50 amps :

- on "ST-BY" **Voltage and current checked
(reset if necessary)**

If the indicated voltage on the "ST BY" generator is low (close to 27 volts), reset the "ST BY" generator and recheck the voltage. The indicated voltage should be in the green range.

- then again on "MAIN"

6 - Flaps **UP**

7 - ECS panel

- "BLEED" switch **ON**
- "FAN FLOW" switch **As required**
- "AIR COND" switch **ON**

A cabin temperature good regulation will only be obtained, if "AIR COND" switch is set to ON.

There is no inconvenience to set "AIR COND" switch to FAN ONLY before starting engine for passenger and crew comfort, provided that voltage is $>$ 25 volts.

- "CABIN TEMP/°C" selector **ADJUST**
- "AIR FLOW" distributor **AS REQUIRED**

Usually selected to CABIN. However, if canopy misting is evident, select DEFOG or HOT to increase demisting efficiency.

Cabin altitude selector **Airfield altitude - 500 feet**

Cabin rate selector **ARROW UPWARDS
(at the halfway post)**

Such a selection will limit cabin rate selector at about \pm 500 ft/min. If selector is turned to the right, limited values of cabin rate selector increase.



AMPLIFIED PROCEDURES

AFTER STARTING ENGINE (4/4)

8 - "RADIO MASTER" switch **ON**
 - VHF/VOR/GPS/TAS/
 EGPWS/WX means (if installed) **ADJUSTED - TESTED**

9 - "EFIS MASTER" switch **ON**
 - "TEST / CMPST" button **PRESS**
 - "TST / REF" button **PRESS at least 3 seconds**
 Detailed control procedures of EFIS system are described in
 Section 9 "Supplements".

10 - "AP / TRIMS MASTER" switch **ON**
 - Preflight test button **PRESS**
 - "AP / TRIMS MASTER" operation **CHECK**
 Detailed control procedures of autopilot and electrical pitch trim are
 described in Section 9 "Supplements".
 - Pitch trim **UP / DN, then ADJUSTED**
 Adjust the indicator in green range (graduated from 12 to 37 % of
 center of gravity) facing corresponding center of gravity.
 - Yaw trim **L / R, then ADJUSTED**
 Adjust the indicator in green range TO (TAKEOFF).
 - Roll trim **L / R, then ADJUSTED**
 Adjust the indicator first at neutral position (horizontal marker).

AMPLIFIED PROCEDURES

**IN-FLIGHT AVAILABLE
 OXYGEN QUANTITY**

Oxygen pressure **Read**

Outside air temperature (IOAT) **Read**

1 - Determine the usable oxygen percent using the chart Figure 4.4.1.

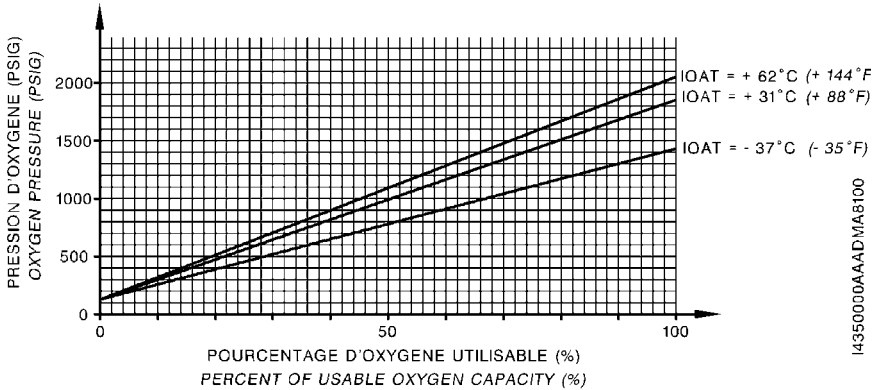

Figure 4.4.1

2 - Determine the oxygen duration in minutes by multiplying the values read on table Figure 4.4.2 by the percent obtained with the chart Figure 4.4.1.

Number of passengers	Duration : Passengers, plus 1 pilot	Duration : Passengers, plus 2 pilots
0	226	113
1	162	94
2	127	81
3	104	71
4	88	65

Figure 4.4.2

AMPLIFIED PROCEDURES

TAXIING (1/2)

1 - "TAXI" light **ON**

2 - "INERT SEP" switch **CHECKED ON**

CHECK WARNING LIGHT **INERT SEP** **ON**

It is recommended that the inertial separator be used during all ground operations.

3 - Passenger briefing **AS REQUIRED**

4 - Parking brake **RELEASED**

Make sure that chocks are removed (if used).

WARNING LIGHT **PARK BRAKE** **OFF**

5 - L.H. and R.H. seat brakes **CHECKED**

6 - Nose wheel steering **CHECKED**

The control wheel will move (roll) in the same direction as the rudder pedals due to the rudder / aileron interconnect.

7 - Power lever **AS REQUIRED**

After initial acceleration, power lever may be in the "TAXI RANGE" sector, avoiding excessive movements in order to keep a constant ground speed.

The condition lever must be in the HI / IDLE position to keep the propeller RPM (Np) out of the caution (yellow) range while taxiing.



AMPLIFIED PROCEDURES

TAXIING (2/2)

CAUTION
AVOID USING REVERSE DURING TAXIING

Operation in the Beta (β) range / reverse is not restricted during ground operations. However, foreign particles (dust, sand, grass, gravel, etc...) may be blown into the air, ingested by the engine (above all if "INERT SEP" switch is turned OFF) and cause damage to the propeller.

- 8 - Flight instruments **CHECK**
Check navigation and communication systems before or during taxiing, check gyroscopic instruments during ground turns.
- 9 - Advisory panel **CHECK**

AMPLIFIED PROCEDURES

BEFORE TAKEOFF (1/3)

1 - Parking brake SET

WARNING LIGHT

PARK BRAKE

ON

2 - Condition lever HI / IDLE

[Ng : 68 % (± 1 %)]

3 - Propeller governor lever **FEATHER twice,
then MAX. RPM**

During this test, the power lever must be at flight idle. Keep the time spent with the propeller RPM in the caution (yellow) range at a minimum.

4 - Fuel
- Gages **CHECK**

(Quantity / Symmetry)

- "FUEL SEL" switch **CHECKED AUTO**

- "AUX BP" switch **CHECKED AUTO**

5 - Flaps **TO**

6 - DE ICE SYSTEM panel
- "AIRFRAME DE ICE" switch **As required**

- "PROP DE ICE" switch **As required**

If runway is in good condition, without icing conditions :

- "INERT SEP" switch **OFF**

WARNING LIGHT

INERT SEP

OFF

Warning light goes out immediately, but it takes 30 seconds to retract the separator.



AMPLIFIED PROCEDURES

BEFORE TAKEOFF (2/3)

If there is standing water or other contamination on the runway :

- "INERT SEP" switch **Left ON**

WARNING LIGHT



ON

- "L.WINDSHIELD" switch **As required**
- "R.WINDSHIELD" switch **As required**
- "PITOT 1 HTR" switch **ON**
- "PITOT 2 & STALL HTR" switch **ON**

- 7 - Advisory panel **CHECK**

All warning lights OFF,

except



ON

and, if used



ON

- 8 - Electronic equipment /
 Flight instruments / Radar **CHECK / ADJUST**
 On ground, maintain radar on SBY in order not to generate
 radiations prejudicial to outside persons.

- 9 - Engine instruments **CHECK**
 All engine parameters must be in green range, except propeller
 RPM, which will be about 1000 RPM or more with power lever at
 IDLE.

- 10 - Pilot's / Passengers' belts **CHECK**

- 11 - Flight controls **DEFLECTIONS CHECKED**



AMPLIFIED PROCEDURES

BEFORE TAKEOFF (3/3)

- 12 - Trims
 - Pitch **ADJUSTED**
 - Yaw **ADJUSTED**
 - Roll **ADJUSTED**
- 13 - Parking brake **RELEASED**

WARNING LIGHT	PARK BRAKE	OFF
---------------	------------	-----
- 14 - "STROBE" switch **ON**

CAUTION
DO NOT TAKE OFF IF BATTERY CHARGE > 50 Amperes

After starting engine with airplane power, a battery charge above 50 amperes is normal. If this indication remains steady at a high value, it may be then a battery or generation system failure. Do not take off in these conditions.

AMPLIFIED PROCEDURES

TAKEOFF (1/3)

(Refer to Supplement 41 for TBM 700C2 airplane)

WHEN LINED UP

CAUTION

- IF HEAVY PRECIPITATION, TURN IGNITION AND INERT SEP ON.
- IF ICING CONDITIONS ARE FORESEEN, REFER TO CHAPTER 4.5, PARAGRAPH "FLIGHT INTO KNOWN ICING CONDITIONS"

- 1 - Heading - HSI - Stand-by compass **CHECK**
The indication of the stand-by compass is disturbed when windshield(s) deice system(s) is (are) activated.
 - Altimeter setting **CHECK**
- 2 - Horizon **Attitude + 2° - CHECK**
Horizon has been set so as to indicate a 2° nose up attitude, when airplane center of gravity is at a middle average.
- 3 - Lights
 - "L.LDG / TAXI / R.LDG" **ON**
- 4 - Engine instruments **CHECK**
(ITT = green sector)
- 5 - Advisory panel **CHECK**

All warning lights OFF,

- except

INERT SEP

 if used
- except

IGNITION

 if used



AMPLIFIED PROCEDURES

TAKEOFF (2/3)

- 6 - Radar switch **As required**
- 7 - PROP O' SPEED GOVERNOR TEST
 - Increase power until propeller RPM reaches 1900 RPM
 - PROP O' SPEED **TEST : Maintain engaged**
 - Observe that propeller RPM decreases by 50 to 250 RPM
 - PROP O' SPEED **TEST : Release**
 - Check that propeller RPM increases by a minimum of 50 RPM when compared to minimum value during PROP O'SPEED test.
- 8 - Brakes **RELEASED**
 It is not necessary to reduce power at the end of "OVERSPEED" test ; torque will be about 40 % before brake release. For a normal takeoff, maximum torque (100 %) will be applied after brake release. On short runway, maximum torque will be applied before brake release.
- 9 - Power lever **TRQ = 100 %**
- 10 - Takeoff **ROTATION : See "Takeoff distances" Chapter 5.8**
 - Normal takeoff **ATTITUDE : 7° 5**
 - Short takeoff **ATTITUDE : 15°**
 Rotation speed at takeoff, according to airplane weight, is also given in Chapter 5.8.
- 11 - Vertical speed indicator **POSITIVE**
- 12 - Brakes **APPLY (Briefly)**



AMPLIFIED PROCEDURES

TAKEOFF (3/3)

13 - Landing gear control (IAS < 128 KIAS) **UP**

During the sequence :

- The red warning light flashes ; it indicates that the landing gear motor is electrically supplied. It goes off when the 3 landing gears are locked. If the red warning light is fixed ON, there is a discrepancy (refer to EMERGENCY PROCEDURES).
- It is possible that the 3 landing gear position green indicator lights flash uncertainly then go off at the end of the sequence.

At sequence end, check : All warning lights OFF

In practice, if preconized attitude is kept, there is no difficulty to maintain a speed < 128 KIAS until landing gear retraction is completed.

14 - Lights

- "TAXI" **OFF**
- "L.LDG / R.LDG" **AS REQUIRED**

15 - Initial climb speed **110 KIAS**

16 - Flaps **UP**

17 - Climb speed (recommended) **130 KIAS**

18 - "YAW DAMPER" push-button **ON**

AMPLIFIED PROCEDURES

CLIMB (1/2)

(Refer to Supplement 41 for TBM 700C2 airplane)

- 1 - Power lever **ADJUST according to engine operation table - Chapter 5.7**

CAUTION

**OBSERVE TRQ / Ng / Np / ITT / T°
AND OIL PRESSURE LIMITATIONS.
USE OPTIMUM TORQUE
AND / OR REFER TO TABLES IN CHAPTER 5.7**

Torque setting during climb must be adjusted according to engine operation tables in Chapter 5.7. These tables give the max. climb power torque setting (MXCL). For each engine, when torque is reduced below 100 % at high altitude according to the tables, the ITT will be approximately constant during final climb, giving a particular value of ITT. For a simplified engine operation during climb, power may be set first of all by torque, using 100 %, then, when the ITT typical value for climb is reached, by indicated ITT, using this particular value. The margin between this indicated ITT and 785°C (recommended ITT limit during continuous operation) will gradually reduce as flight time is performed.

- 2 - Climb speed **AS REQUIRED**
Best climb speed is 123 KIAS. Performance tables concerning climb at 130 and 160 KIAS are given in Chapter 5.9.



AMPLIFIED PROCEDURES

CLIMB (2/2)

- 3 - ECS panel
 - Cabin altitude selector **Cruise altitude + 1000 feet**
 - Cabin rate selector **ADJUST so as to obtain a cabin climb rate of about 500 ft/min**

It concerns the control on triple indicator of cabin rate, as well as increasing of differential pressure and cabin altitude.

- Pressurization **CHECK**
 - "CABIN TEMP/°C" selector **ADJUST**
- 4 - Fuel tank gages **CHECK / CORRECT (Quantity / Symmetry)**

■ Pre-MOD70-0402-28

■ In spite of fuel selector automatic operation, a non-negligible dissymmetry may be observed at the end of climb, for example when 10 minutes of climb have been performed on the same fuel tank. Consequently, it is recommended to select the fullest tank by pushing the "SHIFT" push-button, at the beginning of the climb. Tolerated maximum dissymmetry is 25 us gal (95 Litres).

- 5 - DE ICE SYSTEM **As required Refer to Chapter 4.5 "PARTICULAR PROCEDURES"**

CAUTION
IF HEAVY PRECIPITATION, TURN IGNITION AND INERT SEP ON

AMPLIFIED PROCEDURES

CRUISE (1/2)

- 1 - Power lever **ADJUST according to engine operation table - Chapter 5.7**

As indicated in lower part of these tables, reducing propeller RPM is possible (without touching power lever), in order to improve sound comfort without significant performance change (speed, consumption). However, at the time of this setting, limit permitted by torque limiter may be reached. This limit is 110 % (red line on indicator) at sea level and drops to about 100 % at 31000 ft. Therefore, any propeller RPM reducing performed in altitude from a torque close to 100 % (if ITT limit permits it) will be followed by a non-negligible power (and performance) decrease owing to torque limiter.

CAUTION

**OBSERVE TRQ / Ng / Np / ITT / T°
AND OIL PRESSURE LIMITATIONS.
USE OPTIMUM TORQUE
AND / OR REFER TO TABLES IN CHAPTER 5.7**

Engine operation tables (Chapter 5.7) give torque to be applied according to IOAT, in order not to exceed authorized maximum power.

When "INERT SEP" switch is OFF, a more accurate setting of power must then be performed according to cruise performance tables presented in Chapter 5.10.

- 2 - Pressurization **CHECK**



AMPLIFIED PROCEDURES

CRUISE (2/2)

- 3 - Fuel
 - Gages **CHECK**

REGULARLY CHECK :

- **consumption**

Pre-MOD70-0402-28

- **tank automatic change (every 10 minutes)**

Post-MOD70-0402-28

- **tank automatic change (every 5 minutes)**

All

- **symmetry [max. dissymmetry 25 us gal (95 Litres)]**

- 4 - ETM

When the cruise parameters are fully established :

RECORD **Push**

The SHADIN ETM operation normal procedures are described in the Operation Manual, at the latest revision.

- 5 - DE ICE SYSTEM **As required**

Refer to Chapter 4.5

"PARTICULAR PROCEDURES"

CAUTION

**IF HEAVY PRECIPITATION, TURN IGNITION
AND INERT SEP ON**

AMPLIFIED PROCEDURES

DESCENT (1/2)

- 1 - Altimeter settings **COMPLETE**
- 2 - ECS panel
 - Cabin altitude selector **Airfield altitude + 500 feet**
 - Cabin rate selector **Adjusted**
Set first arrow upwards. This will limit cabin rate at about - 500 ft/min.
- 3 - DE ICE SYSTEM **As required**
Refer to Chapter 4.5
"PARTICULAR PROCEDURES"

CAUTION
IF HEAVY PRECIPITATION, TURN IGNITION
AND INERT SEP ON

The maximum speed for changing the position of the inertial separator is 200 KIAS. Prior to descending into or through known or suspected icing conditions, select "INERT SEP" switch "ON" prior to accelerating beyond 200 KIAS. There are no special speed limitations with the inertial separator secured in either position.

CAUTION
USE OF CONTROL REVERSE BETA (β) RANGE (BEHIND
THE FLIGHT IDLE POSITION) IS PROHIBITED DURING
FLIGHT



AMPLIFIED PROCEDURES

DESCENT (2/2)

- 4 - Windshield misting protection system **As required**
Prior to descent in moist conditions, turn "AIR FLOW" distributor in DEFOG section and set WINDSHIELD switches to "ON" to avoid canopy misting.
If misting continues, set "AIR FLOW" distributor to "HOT" or refer to Chapter 3.12 Paragraph "WINDSHIELD MISTING OR INTERNAL ICING".

- 5 - Fuel
 - Gages **CHECK**
(Quantity / Symmetry)
 - Fullest tank **SELECT**
Even if dissymmetry is < 25 us gal (95 Litres), it is better at this time to choose the fullest tank.

- 6 - Passengers briefing **As required**

- 7 - Seats, belts and harnesses **LOCKED**

AMPLIFIED PROCEDURES

BEFORE LANDING (1/2)

(Refer to Supplement 41 for TBM 700C2 airplane)

Long final

- 1 - Altimeters **CHECK**
- 2 - Fuel
- Gages **CHECK**
(Quantity / Symmetry)
- Fullest tank **SELECT**
Maximum tolerated dissymmetry is 25 us gal (95 Litres).
- 3 - "INERT SEP" switch (IAS \leq 200 KIAS) **ON**
- 4 - Propeller lever **MAX RPM**
- 5 - Landing gear control (IAS \leq 178 KIAS) **DN**

During the sequence :

- The red warning light flashes ; it indicates that the landing gear motor is electrically supplied. It goes off when the 3 landing gears are locked. If the red warning light is fixed ON, there is a discrepancy (refer to EMERGENCY PROCEDURES).
 - It is possible that the 3 landing gear position green indicator lights flash uncertainly then come on at the end of the sequence, indicating that the landing gears are locked in down position.
 - Green indicator lights **ON**
- 6 - Flaps (IAS \leq 178 KIAS) **TO**
- 7 - Lights
- "L.LDG / TAXI / R.LDG" **ON**



AMPLIFIED PROCEDURES

BEFORE LANDING (2/2)

8 - Autopilot **OFF**
Autopilot must be disconnected at the latest at 200 ft above the ground or at decision height or before go-around, whichever is the highest.

9 - Radar switch **SBY**

Short final

10 - Flaps (IAS \leq 122 KIAS) **LDG**
However, when autopilot is engaged, in APR mode, with coupled GS, flaps must be extended in landing position before crossing the OUTER MARKER.

11 - Approach speed (Flaps LDG) **80 KIAS**
To ensure positive and rapid engine response to throttle movement, it is recommended that a minimum of 10 % torque be maintained on final approach until landing is assured.

12 - "YAW DAMPER" push-button OFF The pilot effort required to use the rudder pedals is reduced if the yaw damper is turned off. This is particularly significant when landing in a crosswind.
--

AMPLIFIED PROCEDURES

LANDING

- 1 - Power lever **IDLE**
Avoid three-point landings. Adopt a positive flight attitude in order to touch runway first with main landing gear.

After wheels touch

- 2 - Reverse **As required**
(Reverse may be applied as soon as the wheels touch the ground.)
To avoid ingestion of foreign objects, come out the reverse as speed reduces and use the brakes if necessary for further deceleration.
High power reverse at low speed can throw loose material into the air, and can cause control problems and decrease the comfort of crew and passengers. If permitted by the runway length, it is better to adopt a moderate reverse.

CAUTION

ON SNOWY OR DIRTY RUNWAY, IT IS BETTER NOT TO USE REVERSE

- 3 - Brakes **As required**
It is advised not to brake energetically, as long as speed has not reached 40 KIAS, as otherwise wheels may be locked.

AMPLIFIED PROCEDURES

GO-AROUND

(Refer to Supplement 41 for TBM 700C2 airplane)

- 1 - Simultaneously
- Power lever **TRQ = 100 %**
- Attitude **7° 5**
The airplane will tend to yaw to the left when power is applied. Right rudder pressure will be required to maintain coordinated straight flight until the rudder trim can be adjusted.

- 2 - Flaps **TO**
If speed has been maintained at 80 KIAS or more and TRQ 100 %, select TO flaps as soon as the 8° attitude has been attained.

If the vertical speed is positive and if IAS is at or above 85 KIAS :

- 3 - Landing gear control **UP**
All warning lights OFF

If IAS is at or above 110 KIAS :

- 4 - Flaps **UP**
5 - Climb speed **AS REQUIRED**

AMPLIFIED PROCEDURES

TOUCH AND GO

(Refer to Supplement 41 for TBM 700C2 airplane)

After wheels touch

- 1 - Flaps **TO**
Check that flaps have well reached the TO position before increasing power. Do not increase power with full flaps, as airplane may lift off prematurely at low speed.
- 2 - Elevator trim **Green sector**
To use elevator trim manual control is faster than to use electric control. Ensure that runway length is sufficient to complete this sequence.
- 3 - Power lever **Display TRQ = 100 %**
- 4 - Takeoff **ROTATION : See "Takeoff distances" Chapter 5.8**
 - Normal takeoff **ATTITUDE : 7° 5**
 - Short takeoff **ATTITUDE : 15°**

Rotation speed at takeoff, according to airplane weight, is also given in Chapter 5.8.
However, the pilot's operating handbook does not supply distances concerning touch and go. These distances are let to pilot's initiative.

AMPLIFIED PROCEDURES

AFTER LANDING

RUNWAY CLEAR - AIRPLANE STOPPED

- 1 - DE ICE SYSTEM panel
 - "AIRFRAME DE ICE" switch **OFF**
 - "PROP DE ICE" switch **OFF**
 - "INERT SEP" switch **CHECKED ON**
 - It is highly recommended to use inertial separator during all ground operations.
 - "L.WINDSHIELD" switch **As required**
 - "R.WINDSHIELD" switch **As required**
 - "PITOT 1 HTR" switch **OFF**
 - "PITOT 2 & STALL HTR" switch **OFF**
 - "BLEED" switch **As required**
 - Taxiing with BLEED OFF may slightly help reduce the ITT, thus reducing the required stabilization time before shut-down. This should be applied only for short taxi duration and is left to the pilot judgement.

- 2 - Radar switch **CHECKED SBY**
- Maintain radar on SBY in order not to generate radiations prejudicial to outside persons.

- 3 - Transponder **SBY**

- 4 - Flaps **UP**

- 5 - Lights
 - "L.LDG / R.LDG" **OFF**
 - "TAXI" **ON**

- 6 - "STROBE" switch **OFF**

- 7 - "OXYGEN" switch **OFF**

AMPLIFIED PROCEDURES

SHUT-DOWN (1/2)

- 1 - Parking brake SET
- WARNING LIGHT PARK BRAKE ON
- 2 - "TAXI" light OFF
- 3 - Pressurization
 - "BLEED" switch OFF
 - Check for cabin depressurization
- 4 - "FAN FLOW" switch **As required**
- 5 - "AIR COND" switch OFF
- 6 - Condition lever **HI / IDLE**
- 7 - Power lever **IDLE for 2 minutes**
 This allows the engine to stabilize at minimum obtainable ITT in order to minimize the likelihood of oil coking in the #3 bearing area.
- 8 - GYRO INST panel
 - All switches OFF
- 9 - "EFIS MASTER" switch OFF
- 10 - "AP / TRIMS MASTER" switch OFF
- 11 - "RADIO MASTER" switch OFF
- 12 - Propeller governor lever **FEATHER for 15 seconds**
 Keep propeller governor lever on FEATHER position for 15 seconds minimum before shutting down engine.



AMPLIFIED PROCEDURES

SHUT-DOWN (1/2)

- | | |
|---|-----------------------------------|
| 1 - Parking brake | SET |
| WARNING LIGHT | PARK BRAKE |
| ON | |
| 2 - "TAXI" light | OFF |
| 3 - Pressurization | |
| - "BLEED" switch | OFF |
| - Check for cabin depressurization | |
| 4 - "FAN FLOW" switch | As required |
| 5 - "AIR COND" switch | OFF |
| 6 - Condition lever | HI / IDLE |
| 7 - Power lever | IDLE for 2 minutes minimum |
| This allows the engine to stabilize at minimum obtainable ITT in order to prevent the likelihood of oil coking in the #3 bearing area. ITT is considered stabilized when variations are less than $\pm 5^{\circ}$ C. If BLEED was selected to OFF after landing and taxi was performed at IDLE power, the taxi time is considered as cooling time. Therefore the above stabilization time can be reduced accordingly. | |
| 8 - GYRO INST panel | |
| - All switches | OFF |
| 9 - "EFIS MASTER" switch | OFF |
| 10 - "AP / TRIMS MASTER" switch | OFF |
| 11 - "RADIO MASTER" switch | OFF |
| 12 - Propeller governor lever | FEATHER for 15 seconds |
| Keep propeller governor lever on FEATHER position for 15 seconds minimum before shutting down engine. | |



AMPLIFIED PROCEDURES

SHUT-DOWN (2/2)

13 - Condition lever **CUT OFF**

CAUTION

IN CASE OF SHUT-DOWN ON A CONTAMINATED AREA :

- **Condition lever** **CUT OFF**
- **Propeller governor lever** **FEATHER**

14 - Fuel
When fuel pressure is below 10 psi (\pm 2 psi), check "AUX BP" pump is operating.

- "AUX BP" switch **OFF**
- "FUEL SEL" switch **MAN**
- Tank selector **OFF**

15 - "INERT SEP" switch **OFF**

16 - INT LIGHTS panel
- All switches **OFF**

17 - EXT LIGHTS panel
- All switches **OFF**

18 - "GENERATOR" selector **OFF**

19 - "SOURCE" selector **OFF**

CAUTION

IN CASE OF HIGH OAT [ABOVE 35° C (95° F)], IT IS REQUIRED TO PERFORM 30 SECONDS DRY MOTORING RUN AFTER SHUT-DOWN TO IMPROVE COOLING OF THE BEARING CAVITIES AND MINIMIZE OIL COKING (REFER TO PARAGRAPH "MOTORING")

AMPLIFIED PROCEDURES

SHUT-DOWN (2/2)

13 - Condition lever **CUT OFF**

CAUTION

IN CASE OF SHUT-DOWN ON A CONTAMINATED AREA :

- **Condition lever** **CUT OFF**
- **Propeller governor lever** **FEATHER**

14 - Fuel

When fuel pressure is below 10 psi (\pm 2 psi), check "AUX BP" pump is operating.

- "AUX BP" switch **OFF**
- "FUEL SEL" switch **MAN**
- Tank selector **OFF**

15 - "INERT SEP" switch **OFF**

16 - INT LIGHTS panel

- All switches **OFF**

17 - EXT LIGHTS panel

- All switches **OFF**

18 - "GENERATOR" selector **OFF**

19 - "SOURCE" selector **OFF**

CAUTION

IN CASE OF HIGH OAT [ABOVE 35° C (95° F)], IT IS RECOMMENDED TO PERFORM 30 SECONDS DRY MOTORING RUN AFTER SHUT-DOWN TO IMPROVE COOLING OF THE BEARING CAVITIES AND PREVENT OIL COKING (REFER TO PARAGRAPH "MOTORING")

4.5 - PARTICULAR PROCEDURES

REMARK :

The procedures and procedure elements given in this Chapter "PARTICULAR PROCEDURES" supplement the normal procedures or complete certain elements of the normal procedures described in Chapter(s) 4.3 and/or 4.4.

FLIGHT INTO KNOWN ICING CONDITIONS (1/5)

(Refer to Supplement 41 for TBM 700C2 airplane)

General

- 1 - Icing conditions exist when the IOAT on the ground or in flight is + 13°C or below, and visible moisture in any form is present (clouds, fog with visibility of one mile (1.6 km) or less, rain, snow, sleet or ice crystals).
- 2 - Icing conditions also exist when the IOAT on the ground is + 13°C or below and when operating on ramps, taxiways or runways where surface snow, ice, standing water or slush may be ingested by the engine or freeze on engine or cowlings.

NOTE :

Refer to Figure 5.4.1 to convert IOAT to SAT in flight.

$SAT = IOAT - 2^{\circ}C$ on the ground.

- 3 - Flight into known icing conditions is authorized when all airplane equipment provided for ice protection is operating correctly. This includes :
 - Pneumatic deice system for inboard and outboard wing, for stabilizers and for elevator horns.
 - Propeller electrical deice system.
 - Electrical heating system for both pitots and for the stall warning incidence sensor.
 - Windshield electrical deice system.
 - Inertial separator.

Description of deice systems is presented in Chapter 7.13.

Ice accumulation thickness is monitored by the pilot on the L.H. wing leading edge.

At night, a leading edge icing inspection light located on the fuselage L.H. side, activated by the "ICE LIGHT" switch, is provided.

PARTICULAR PROCEDURES

FLIGHT INTO KNOWN ICING CONDITIONS (2/5)

Boots are automatically cycling at the optimum time to assure proper ice removal. Correct operation of the system can be checked observing the corresponding green advisory light illumination at each boot inflation impulse. If correct operation cannot be confirmed, do not enter or leave as soon as possible icing conditions.

Apply "LEADING EDGES DEICING FAILURE" emergency procedure.

Ice protection procedures

1 - Prior to entering IMC, as a preventive :

If IOAT \leq 13° C :

- "INERT SEP" switch **ON**
- "IGNITION" switch **ON**
- "PROP DE ICE" switch **ON**
- "AIRFRAME DE ICE" switch **ON**
- "WINDSHIELD DE ICE" switch **ON**

2 - When operating under IMC :

- "INERT SEP" switch **ON**
- "IGNITION" switch **ON**
- "PROP DE ICE" switch **ON**
- "AIRFRAME DE ICE" switch **ON**
- "WINDSHIELD DE ICE" switch **ON**

NOTE :

When IOAT is below - 25° C, avoid operations of the "AIRFRAME DEICE SYSTEM" for a too long period because the boots could be damaged. The "INERT SEP" switch must be left ON while the airplane remains in icing conditions.

PARTICULAR PROCEDURES

FLIGHT INTO KNOWN ICING CONDITIONS (3/5)

CAUTION

**SHOULD CONDITIONS REQUIRE IT, APPLY THESE DIRECTIVES
FROM BEGINNING OF TAXI ONWARDS**

CAUTION

**DO NOT OPERATE THE INERTIAL SEPARATOR IF THE AIRSPEED
EXCEEDS 200 KIAS. THERE IS NO SPEED LIMITATION WHEN
THE INERTIAL SEPARATOR IS IN FIXED POSITION**

If a high speed descent (> 200 KIAS) is anticipated into known icing conditions, position "INERT SEP" switch to ON before accelerating. This will avoid reducing speed below 200 KIAS during descent to set the inertial separator.

**IF AIRPLANE LEAVES ICING CONDITIONS, MAINTAIN "INERT SEP" ON
AS LONG AS ICE THICKNESS ON NON-DEICED VISIBLE PARTS
EXCEEDS 15 mm (OR ½ INCH)**

This will avoid ice fragments coming from propeller spinner and being ingested by engine.

**INERTIAL SEPARATOR POSITION AFFECTS ENGINE PARAMETERS
(PARTICULARLY TRQ AND ITT). CARE MUST BE EXERCISED WHEN
OPERATING THE INERTIAL SEPARATOR OR WHEN INCREASING
POWER WITH THE INERTIAL SEPARATOR ON, TO AVOID EXCEEDING
ENGINE LIMITATIONS**

NOTE :

"IGNITION" switch may be left ON for a long period.

Standby compass indications are altered when windshield deicing system(s) operate(s).

PARTICULAR PROCEDURES

FLIGHT INTO KNOWN ICING CONDITIONS (4/5)

- 3 – Procedures for holding, approach and landing in icing conditions :
- Minimum recommended speeds are :
 - . Flaps UP 130 KIAS
 - . Flaps TO 110 KIAS
 - . Flaps LDG 90 KIAS
 - If there is ice on the unprotected surfaces of the airplane, during flight end phase, conduct holding with the flaps up. Use flaps as required for final approach and landing at minimum speeds noted above.

Ice accumulation effects

When ice has accumulated on the unprotected surfaces of the airplane, aerodynamic characteristics may be changed.

Particularly stall speeds may increase by up to :

- Flaps UP 20 KIAS
- Flaps TO 15 KIAS
- Flaps LDG 10 KIAS

Correct operation of the aural stall warning may be altered by severe or prolonged icing.

Indeed, in case of severe or prolonged icing, an ice concretion due to refreezing around the heated stall warning may appear. Above-recommended speeds take into account, on one side, the stall speed increase due to profile shape deterioration and, on the other side, the weight increase of the iced-up airplane (taking as a basis the airplane maximum weight when not iced-up).

Rate of climb values with ice accumulation on the unprotected surfaces are to be decreased by 10 %.

PARTICULAR PROCEDURES

FLIGHT INTO KNOWN ICING CONDITIONS (5/5)

Cruise speeds may be decreased by 10 %, if cruise power is not changed, or more, if cruise power setting should be decreased due to the additional inertial separator limitations (ITT limitation).

Because of the higher landing speed, landing distances will be increased. In the landing configuration, using 90 KIAS approach speed increases landing distance by 20 % – refer to Chapter 5.13 "LANDING DISTANCES".

PARTICULAR PROCEDURES

FLIGHT INTO SEVERE ICING CONDITIONS (1/2)

**THE FOLLOWING WEATHER CONDITIONS MAY BE CONDUCTIVE
TO SEVERE IN-FLIGHT ICING :**

- Visible rain at temperatures below 0°C ambient air temperature,
- Droplets that splash or splatter on impact at temperatures below 0°C ambient air temperature.

Procedures for exiting the severe icing environment

REMARK :

These procedures are applicable to all flight phases from takeoff to landing.

Monitor the ambient air temperature. While severe icing may form at temperatures as cold as - 18°C, increased vigilance is warranted at temperatures around freezing with visible moisture present. If the visual cues specified in Section 2 "Limitations" for identifying severe icing conditions are observed, accomplish the following :

- 1 - Immediately request priority handling from Air Traffic Control to facilitate a route or an altitude change to exit the severe icing conditions in order to avoid extended exposure to flight conditions more severe than those for which the aircraft has been certificated.
- 2 - Avoid abrupt and excessive maneuvering that may exacerbate control difficulties.
- 3 - Do not engage the autopilot.
- 4 - If the autopilot is engaged, hold the control wheel firmly and disengage the autopilot.
- 5 - If an unusual roll response or uncommanded roll control movement is observed, reduce the angle-of-attack.

PARTICULAR PROCEDURES

FLIGHT INTO SEVERE ICING CONDITIONS (2/2)

- 6 - Do not extend flaps when holding in icing conditions. Operation with flaps extended can result in a reduced wing angle-of-attack, with the possibility of ice forming on the upper surface further aft on the wing than normal, possibly aft of the protected area.
- 7 - If the flaps are extended, do not retract them until the airframe is clear of ice.
- 8 - Report these weather conditions to Air Traffic Control.

PARTICULAR PROCEDURES

FLIGHT UNDER HEAVY PRECIPITATIONS

- 1 - "IGNITION" switch **ON**
This action is intended, in highly improbable case of an engine flame-out further to an important ingestion, to ensure immediate restarting without action of the pilot.

- 2 - "INERT SEP" switch **ON**

UTILIZATION ON RUNWAYS COVERED WITH WATER

If takeoff or landing must be performed on a runway covered with water :

- 1 - "IGNITION" switch **ON**
- 2 - "INERT SEP" switch **ON**

PARTICULAR PROCEDURES

UTILIZATION ON RUNWAYS COVERED WITH MELTING OR NOT TAMPED SNOW (1/2)

Refer if required to paragraph "UTILIZATION BY COLD WEATHER AND VERY COLD WEATHER".

Preflight inspection

- 1 - Remove any snow or ice from the wings, stabilizers and movable surfaces, landing gear wells and gear doors, as well as flap tracks, actuators and their fairings.
- 2 - Spray anti-icing fluid on the wings, stabilizers and movable surfaces (upper and lower surfaces) and in the landing gear wells, shortly before takeoff.

Taxiing

- 1 - "INERT SEP" switch **ON**
- 2 - Taxi at very slow speed (max. 5 KIAS), flaps up, brake occasionally to maintain the brake pads warm (this will prevent any subsequent locking due to freezing after takeoff).

Before takeoff

- 1 - If the runway is long enough, takeoff should be performed with the flaps in the up position. In that case, rotation speed must be increased by 5 KIAS.

NOTE :

Takeoff distances must be increased to take into account the flap position (+ 15 % compared to the takeoff position) and the runway condition.

The ground roll may be multiplied by 3 in some melting or not tamped snow cases.

- 2 - "IGNITION" switch **ON**
- 3 - "INERT SEP" switch **ON**

PARTICULAR PROCEDURES

**UTILIZATION ON RUNWAYS COVERED WITH MELTING
OR NOT TAMPED SNOW (2/2)**

Takeoff

- 1 - Lightly lift up nose wheel during takeoff run in order to reduce the forward resistance due to snow accumulation against the wheel.
- 2 - After takeoff, normally retract the landing gear, then perform a complete cycle (extension / retraction) at IAS \leq 128 KIAS.

Before landing

- 1 - "IGNITION" switch **ON**
- 2 - "INERT SEP" switch **ON**

Touch and Go

Prohibited

On the ramp, after landing or taxiing :

- 1 - Do not use the parking brake to prevent brake lock.
- 2 - Use chocks and / or tie-down the airplane.

PARTICULAR PROCEDURES

**UTILIZATION ON ICY OR COVERED WITH
TAMPED SNOW RUNWAYS (1/2)**

Refer if required to paragraph "UTILIZATION BY COLD WEATHER AND VERY COLD WEATHER".

Preflight inspection

- 1 - Remove any snow or ice from the wings, stabilizers and movable surfaces, landing gear wells and gear doors, as well as flap tracks, actuators and their fairings.
- 2 - Spray anti-icing fluid on the wings, stabilizers and movable surfaces (upper and lower surfaces), shortly before takeoff.

Taxiing

- 1 - "INERT SEP" switch **ON**
- 2 - Taxi at very slow speed (max. 5 KIAS).
Use β area of power lever to adjust speed.
Apply very smooth variations using power lever.
- 3 - Steer the airplane using the rudder.
Make turns at a very low speed, engine torque tends to make the airplane turn to the left.
- 4 - Use brakes only at very low speed and progressively.

Before takeoff

- 1 - "IGNITION" switch **ON**
- 2 - "INERT SEP" switch **ON**

Takeoff

- 1 - After takeoff, normally retract the landing gear, then perform a complete cycle (extension / retraction) at IAS \leq 128 KIAS.

Before landing

- 1 - "IGNITION" switch **ON**
- 2 - "INERT SEP" switch **ON**

PARTICULAR PROCEDURES

**UTILIZATION ON ICY OR COVERED WITH
TAMPED SNOW RUNWAYS (2/2)**

Landing

After wheel touch

- 1 - Use reverse only if necessary and very progressively by monitoring the airplane behaviour.
The engine torque tends to make the airplane turn to the left.
- 2 - Taxi at very slow speed (max. 5 KIAS).
Use β area of power lever to adjust speed.
Apply very smooth variations using power lever.
- 3 - Steer the airplane using the rudder.
Make turns at a very low speed, engine torque tends to make the airplane turn to the left.
- 4 - Use brakes only at very low speed and progressively.

On the ramp, after landing or taxiing :

- 1 - Do not use the parking brake to prevent brake lock.
- 2 - Use chocks and / or tie-down the airplane.

PARTICULAR PROCEDURES

UTILIZATION BY COLD WEATHER (- 0° C TO - 25° C) AND VERY COLD WEATHER (- 25° C TO - 40° C) (1/10)

REMARK :

The procedures hereafter supplement the normal procedures for the airplane use when operating under temperatures between 0° C and - 40° C on ground.

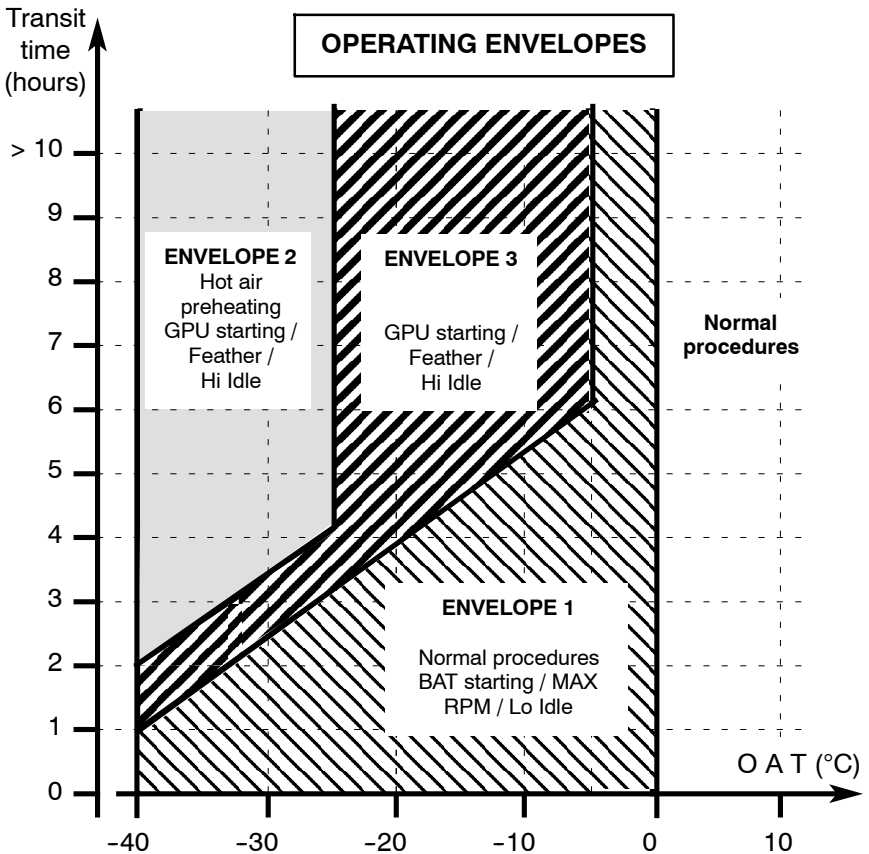

Figure 4.5.1 - OPERATING ENVELOPES BY COLD WEATHER (- 0° C to - 25° C) AND VERY COLD WEATHER (- 25° C to - 40° C)

PARTICULAR PROCEDURES

UTILIZATION BY COLD WEATHER (- 0° C TO - 25° C) AND VERY COLD WEATHER (- 25° C TO - 40° C) (2/10)

ENVELOPE 1

The procedures hereafter supplement the normal procedures for the airplane use when operating in the "envelope 1" defined in Figure 4.5.1.

Preflight inspection

- 1 - Remove any snow or ice from the wings, stabilizers and movable surfaces.

Apply, according to the condition of runways and taxiways, the procedures "UTILIZATION ON RUNWAYS COVERED WITH MELTING OR NOT TAMPED SNOW" or the procedures "UTILIZATION ON ICY OR COVERED WITH TAMPED SNOW RUNWAYS".

- 2 - Carry out a complete rotation of the propeller to check its free rotation.
- 3 - Do not perform a fuel draining. If the airplane is operating permanently under negative temperatures, drainings will have to be performed once a week after having parked the airplane in a heated hangar.
- 4 - Remove chocks and / or release ties from the airplane.
- 5 - Check the free deflection of the flight controls and of the elevator trim.
- 6 - Check the free deflection of the power lever and of the propeller governor lever.

Before starting the engine / Starting the engine / After starting the engine

Apply normal procedures defined in Chapter(s) 4.3 and / or 4.4.

PARTICULAR PROCEDURES

UTILIZATION BY COLD WEATHER (- 0° C TO - 25° C) AND VERY COLD WEATHER (- 25° C TO - 40° C) (3/10)

Taxiing / Before takeoff / Takeoff

- 1 - On "DE-ICE SYSTEM" panel :
 - "INERT SEP" switch ON
- | | | |
|---------------|-----------|----|
| WARNING LIGHT | INERT SEP | ON |
|---------------|-----------|----|
- "PITOT 1 HTR" switch ON
 - "PITOT 2 & STALL HTR" switch ON
 - "PROP DE-ICE" switch ON
- 2 - Apply normal procedures
 - 3 - Apply, according to the condition of runways and taxiways, the procedures "UTILIZATION ON RUNWAYS COVERED WITH MELTING OR NOT TAMPED SNOW" or the procedures "UTILIZATION ON ICY OR COVERED WITH TAMPED SNOW RUNWAYS".

Landing / After landing

- 1 - Apply normal procedures defined in Chapter(s) 4.3 and / or 4.4.
- 2 - Apply, according to the condition of runways and taxiways, the procedures "UTILIZATION ON RUNWAYS COVERED WITH MELTING OR NOT TAMPED SNOW" or the procedures "UTILIZATION ON ICY OR COVERED WITH TAMPED SNOW RUNWAYS".

Shut down

- 1 - Parking brake **RELEASED**
- | | | |
|---------------|------------|-----|
| WARNING LIGHT | PARK BRAKE | OFF |
|---------------|------------|-----|

It is recommended not to use the parking brake by cold or very cold weather, so that the brakes do not stick when cooling.

- 2 - Apply normal procedures defined in Chapter(s) 4.3 and / or 4.4.
- 3 - Use chocks and / or tie-down the airplane using anchor points on ground.
- 4 - Put blanking caps and plugs on air inlets, exhaust stubs, pitots and static ports.

PARTICULAR PROCEDURES

UTILIZATION BY COLD WEATHER (- 0° C TO - 25° C) AND VERY COLD WEATHER (- 25° C TO - 40° C) (4/10)

ENVELOPE 2

The procedures hereafter supplement or replace the normal procedures for the airplane use when operating in the "envelope 2" defined in Figure 4.5.1.

Preflight inspection

- 1 - Preheat the engine and the cabin.

Preheating the engine and the cabin during at least 30 minutes is necessary using a heater (70°C mini). Hot air pipes must be installed :

- in the air inlet,
- on engine rear table by opening the upper cowling,
- in the cabin by half-opening the door,
- in the R.H. front compartment for the EFIS versions during 10 minutes at the end of the engine preheating.

- 2 - Remove any snow or ice from the wings, stabilizers and movable surfaces.

Apply, according to the condition of runways and taxiways, the procedures "UTILIZATION ON RUNWAYS COVERED WITH MELTING OR NOT TAMPED SNOW" or the procedures "UTILIZATION ON ICY OR COVERED WITH TAMPED SNOW RUNWAYS".

- 3 - Spray anti-icing fluid on the wings, stabilizers and movable surfaces (upper and lower surfaces), shortly before takeoff.
- 4 - Carry out a complete rotation of the propeller to check its free rotation.
- 5 - Do not perform a fuel draining. If the airplane is operating permanently under negative temperatures, drainings will have to be performed once a week after having parked the airplane in a heated hangar.

PARTICULAR PROCEDURES

UTILIZATION BY COLD WEATHER (- 0° C TO - 25° C) AND VERY COLD WEATHER (- 25° C TO - 40° C) (5/10)

- 6 - Remove chocks and / or release ties from the airplane.
- 7 - Check the free deflection of the flight controls and of the elevator trim.
- 8 - Check the free deflection of the power lever and of the propeller governor lever.



This enables to preheat spark igniters before starting the engine.

Before starting the engine

Apply normal procedures defined in Chapter(s) 4.3 and / or 4.4.

Starting the engine

The starting must be mandatorily performed using an external power source (GPU).

- 1 - Ground power unit **CONNECTED**
 - 2 - "SOURCE" selector **GPU**
- | | | |
|---------------|--|----|
| WARNING LIGHT | <div style="border: 1px solid black; padding: 2px; display: inline-block;">GPU</div> | ON |
| WARNING LIGHT | <div style="border: 1px solid black; padding: 2px; display: inline-block;">BAT OFF</div> | ON |
- Voltmeter **VOLTAGE CHECKED**
(V = 28 Volts)

PARTICULAR PROCEDURES

UTILIZATION BY COLD WEATHER (- 0° C TO - 25° C) AND VERY COLD WEATHER (- 25° C TO - 40° C) (6/10)

- 3 - Engine controls
 - "MAN OVRD" control **OFF (Notched)**

CAUTION
WHEN THE ENGINE IS SHUTDOWN, THE POWER LEVER MUST NOT BE MOVED BEHIND THE FLIGHT IDLE POSITION

- Power lever **IDLE**
- Propeller governor lever **Feather**
- Condition lever **CUT OFF**

- 4 - Fuel panel
 - "AUX BP" switch **ON**



- Fuel pressure indicator **Check**

- 5 - Propeller **AREA CLEAR**

- 6 - "ENGINE START" panel

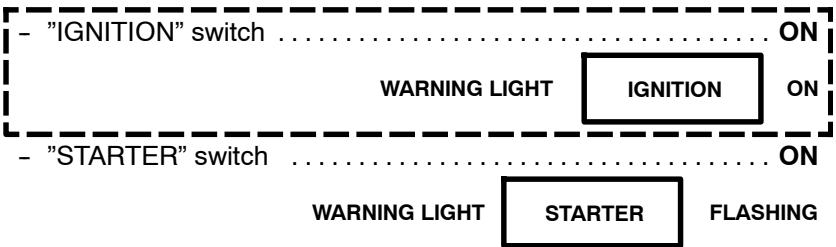

PARTICULAR PROCEDURES

UTILIZATION BY COLD WEATHER (- 0° C TO - 25° C) AND VERY COLD WEATHER (- 25° C TO - 40° C) (7/10)

Ng ≈ 13 %

- Condition lever **HI / IDLE**

Move directly condition lever to HI / IDLE

NOTE :

The more the temperature is low, the more the selector is hard to move.

Starter limits and checks of starting sequence are unchanged.

■ 7 - Engine instruments **Check NG = 68 % (± 1 %)**
(Oil pressure / ITT = green sector)

8 - "SOURCE" selector **BAT**
WARNING LIGHT **BAT OFF** OFF

9 - "IGNITION" switch **AUTO**
WARNING LIGHT **IGNITION** OFF

10 - Ground power unit **HAVE IT DISCONNECTED**
WARNING LIGHT **GPU** OFF

11 - "FUEL" panel
- "AUX BP" switch **AUTO**
WARNING LIGHT **AUX BP ON** OFF

12 - Generator **WARNING LIGHT** **MAIN GEN** OFF
RESET if necessary

PARTICULAR PROCEDURES

UTILIZATION BY COLD WEATHER (- 0° C TO - 25° C) AND VERY COLD WEATHER (- 25° C TO - 40° C) (8/10)

After starting the engine

- 1 - On "ECS" panel

As soon as the current flow is lower than 100 A :

- "BLEED" switch **ON**
- "CABIN TEMP/° C" selector **FULL HOT**

- 2 - Propeller governor lever

As soon as the oil temperature is greater than 0°C :

- Propeller governor lever **MAX. RPM**
- Perform 2 propeller regulations

- 3 - Apply normal procedures defined in Chapter(s) 4.3 and / or 4.4.

Taxiing / Before takeoff / Takeoff

Apply procedures defined for Envelope 1.

Landing / After landing / Shut down

Apply procedures defined for Envelope 1.

PARTICULAR PROCEDURES

UTILIZATION BY COLD WEATHER (- 0° C TO - 25° C) AND VERY COLD WEATHER (- 25° C TO - 40° C) (9/10)

ENVELOPE 3

The procedures defined for the "envelope 2" are also applicable for the "envelope 3". However it is possible to start the engine using GPU **without preheating of the engine and the cabin** with a heater. In that case the procedure "After starting the engine" is modified as follows :

Preflight inspection / Before starting the engine / Starting the engine

Apply the procedures defined for the Envelope 2.

After starting the engine

- 1 - "ECS" panel

As soon as the current flow is lower than 100 A :

- "BLEED" switch **ON**
- "CABIN TEMP/°C" selector **FULL HOT**

Preheat the cabin respecting time defined in Figure 4.5.2 before switching on the navigation and monitoring systems. This allows to respect minimum temperatures necessary for the equipment operation.

- 2 - Propeller governor lever

As soon as the oil temperature is greater than 0°C :

- Propeller governor lever **MAX. RPM**
- Perform 2 propeller regulations

- 3 - Apply normal procedures defined in Chapter(s) 4.3 and / or 4.4.

PARTICULAR PROCEDURES

UTILIZATION BY COLD WEATHER (- 0° C TO - 25° C) AND VERY COLD WEATHER (- 25° C TO - 40° C) (10/10)

Taxiing / Before takeoff / Takeoff

Apply procedures defined for Envelope 1.

Landing / After landing / Shut down

Apply procedures defined for Envelope 1.

Complement

If landing is foreseen by cold or very cold weather, or in case of prolonged operation of the airplane in such conditions, it is recommended to prepare the airplane as specified in Chapter 8.9.

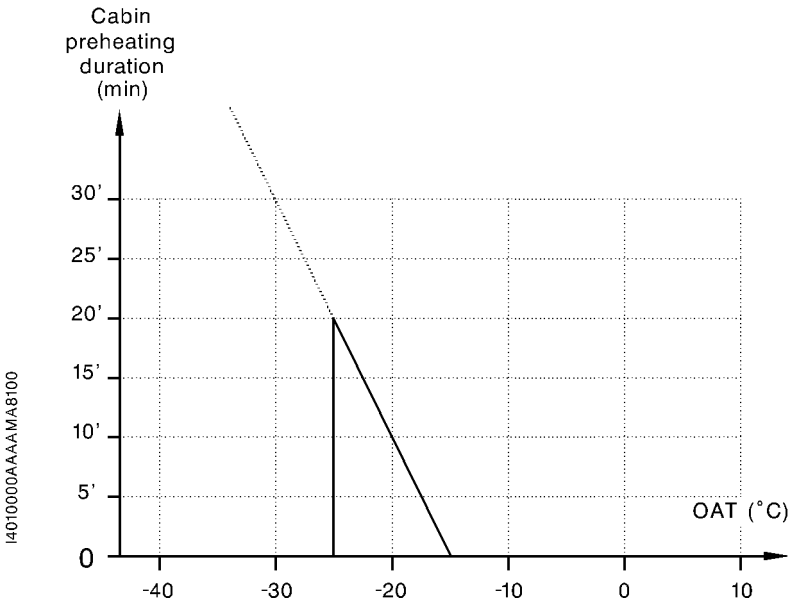

Figure 4.5.2 - PREHEATING DURATION

PARTICULAR PROCEDURES

**LANDING PROCEDURE WITH STRONG HEADWIND
OR CROSSWIND (1/2)**

If landing must be performed with strong headwind or crosswind, increase approach speed by the greatest of these 2 following values :

$$- \Delta V = \frac{(\text{WIND DOWN} - 10)}{2} \quad (\text{Ex. WIND DOWN} = 30 \text{ kt i.e. } \Delta V = 10 \text{ kt})$$

The wind down is the longitudinal component of the wind.

- Gust amplitude

Use flaps LDG.

It is not desirable to adopt configuration with flaps TO. Lateral control is not improved, and flare phase is lengthened in time and in distance, with increase of piloting difficulties and landing performance.

During approach with crosswind, maintain airplane in drift correction at the latest until the beginning of flare.

In short final, on a short runway, it is necessary to use normal approach speed (80 KIAS) with flaps LDG, in order to avoid an excessive speed. Indeed, in this case, landing distance indicated in Chapter 5.13, would not be respected.

Before touch-down, generate a slideslip with the rudder in order to align fuselage with the runway (ie left crosswind, left wing low).

Do not use or select the fuel tank on the low wing side during prolonged sideslips with a fuel low warning or gage indicating low.

Retract flaps immediately after landing.

Flap travel is slow and will not have an appreciable effect on landing performance.

PARTICULAR PROCEDURES

LANDING PROCEDURE WITH STRONG HEADWIND OR CROSSWIND (2/2)

Do not try to stabilize the airplane by pushing down the elevator control just after the touch ; this operation may provide pitch oscillations while increasing the yaw movement to the wind.

Do not deflect ailerons into wind while taxiing. This will raise spoilers and have a detrimental effect. A good solution is to maintain ailerons to neutral position during second taxi phase after landing and during first taxi phase before takeoff.

Maximum demonstrated crosswind for landing is 20 kt.

The most restrictive situation is as follows :

- takeoff with wind coming from the left,
- wet runway,
- aft C.G.

PARTICULAR PROCEDURES

UTILIZATION ON GRASS RUNWAY

CAUTION
**THE SMALL WHEELS OF THE AIRPLANE AND ITS WEIGHT MAY
LEAD IT TO SINK IN SOPPY OR LOOSE GROUND**

Before planning the landing, ensure that the field is hard, smooth and dry enough. Landing and, a fortiori, takeoff shall not be envisaged if any doubt exists about the condition of such a runway.

Particular directives

TAXI / TAKEOFF

- 1 - "INERT SEP" switch **ON**
- 2 - Reverse **Do not use**
In fact, on a flat runway with grass, it is necessary to adopt a power greater than the one obtained when the power lever is set to IDLE, so the pilot will not be tempted to use the reverse.

LANDING

- 1 - "INERT SEP" switch **ON**

After wheel touch down :

- 2 - Reverse **Only if necessary**

Do not maintain reverse at speeds below 40 KIAS to avoid ingestion of foreign matter.

Indeed, under this speed, using the reverse makes a cloud of solid particles (dusts, sand, gravels, trocken grass, and so on ...) appear around the front face of the airplane. This will damage the propeller and, after ingestion, the engine internal components (compressor and turbine blades).

PARTICULAR PROCEDURES

OPERATION IN RVSM CONDITIONS

After altitude capture, in altitude hold mode of the autopilot, discrepancy between desired altitude and held altitude must be adjusted using the vertical trim control in order not to exceed ± 20 ft.

In RVSM area, the transponder # 1 must be used first.

SECTION 5

PERFORMANCE

TABLE OF CONTENTS

		Page
5.1	ACOUSTIC LIMITATION	5.1.1
5.2	AIRSPEED CALIBRATION	5.2.1
5.3	CABIN PRESSURIZATION ENVELOPE	5.3.1
5.4	SAT - IOAT CONVERSIONS	5.4.1
5.5	STALL SPEEDS	5.5.1
5.6	WIND COMPONENTS	5.6.1
5.7	ENGINE OPERATION	5.7.1
	Maximum climb power (FL ≤ 200)	5.7.2
	Maximum climb power (FL ≥ 200)	5.7.3
	Maximum cruise power (FL ≤ 200)	5.7.4
	Maximum cruise power (FL ≥ 200)	5.7.5
	Normal (recommended) cruise power (FL ≤ 200)	5.7.6
	Normal (recommended) cruise power (FL ≥ 200)	5.7.7
5.8	TAKEOFF DISTANCES	5.8.1
5.9	CLIMB PERFORMANCE	5.9.1
	CLIMB SPEEDS (IAS = 130 KIAS)	5.9.1
	CLIMB SPEEDS (IAS = 160 KIAS)	5.9.2
	TIME, CONSUMPTION AND CLIMB	
	DISTANCE (IAS = 130 KIAS)	5.9.3
	TIME, CONSUMPTION AND CLIMB	
	DISTANCE (IAS = 160 KIAS)	5.9.6
	CLIMB PERFORMANCE AFTER GO-AROUND	5.9.9
	CLIMB PERFORMANCE - FLAPS TO	5.9.10

TABLE OF CONTENTS
(Continued)

	Page
5.10 CRUISE PERFORMANCE	5.10.1
Maximum cruise	5.10.2
Normal (recommended) cruise	5.10.9
Intermediate cruise	5.10.16
Long Range cruise (5512 lbs - 2500 kg) (Altitude \leq 24000 ft) ..	5.10.23
Long Range cruise (5512 lbs - 2500 kg) (Altitude \geq 24000 ft) ..	5.10.24
Long Range cruise (6173 lbs - 2800 kg) (Altitude \leq 24000 ft) ..	5.10.25
Long Range cruise (6173 lbs - 2800 kg) (Altitude \geq 24000 ft) ..	5.10.26
5.11 TIME, CONSUMPTION AND DESCENT DISTANCE	5.11.1
5.12 HOLDING TIME	5.12.1
5.13 LANDING DISTANCES	5.13.1
Weight : 6250 lbs (2835 kg)	5.13.1
Weight : 5071 lbs (2300 kg)	5.13.2

5.1 - ACOUSTIC LIMITATION

(Refer to Supplement 41 for TBM 700C2 airplane)

	Maximum noise level permissible	Demonstrated noise level
FAR PART 36, Appendix G - Amdt 17	85 dB(A)	77.4 dB(A)
ICAO, Annex 16, Chapter 10, Appendix 6	88 dB(A)	80.4 dB(A)

TBM 700 airplane has received the noise limitation type certificate Nr N181 dated 31st January 1990 replaced by the Type Certificate Data Sheet EASA.A.010 on 14th July 2004.

INTENTIONALLY LEFT BLANK

5.2 - AIRSPEED CALIBRATION

NOTE :

Indicated airspeeds (IAS) : instrument error supposed to be null (power configuration for cruise condition flight).

FLAPS UP LDG GR UP		FLAPS TO LDG GR DN		FLAPS LDG LDG GR DN	
KIAS	KCAS	KIAS	KCAS	KIAS	KCAS
125	127	70	69	60	58
150	152	80	80	70	68
175	177	90	90	80	78
200	205	100	101	90	88
225	228	120	121	100	98
250	253	140	141	110	108
266	271	160	162	120	118
MPH IAS	MPH CAS	MPH IAS	MPH CAS	MPH IAS	MPH CAS
144	146	81	79	69	67
173	175	92	92	81	78
201	204	104	104	92	90
230	233	115	116	104	101
259	262	138	139	115	113
288	292	161	162	127	124
307	311	184	187	138	136

Figure 5.2.1 - NORMAL STATIC SOURCE

FLAPS UP LDG GR UP		FLAPS TO LDG GR DN		FLAPS LDG LDG GR DN	
KIAS	KCAS	KIAS	KCAS	KIAS	KCAS
125	124	70	70	60	59
150	149	80	80	70	69
175	174	90	90	80	79
200	199	100	100	90	90
225	224	120	120	100	100
250	249	140	139	110	110
271	270	160	159	120	120
MPH IAS	MPH CAS	MPH IAS	MPH CAS	MPH IAS	MPH CAS
144	142	81	81	69	68
173	171	92	92	81	79
201	200	104	104	92	91
230	229	115	115	104	104
259	258	138	138	115	115
288	287	161	160	127	127
312	311	184	183	138	138

Figure 5.2.2 - ALTERNATE STATIC SOURCE (BLEED ON)

5.3 - CABIN PRESSURIZATION ENVELOPE

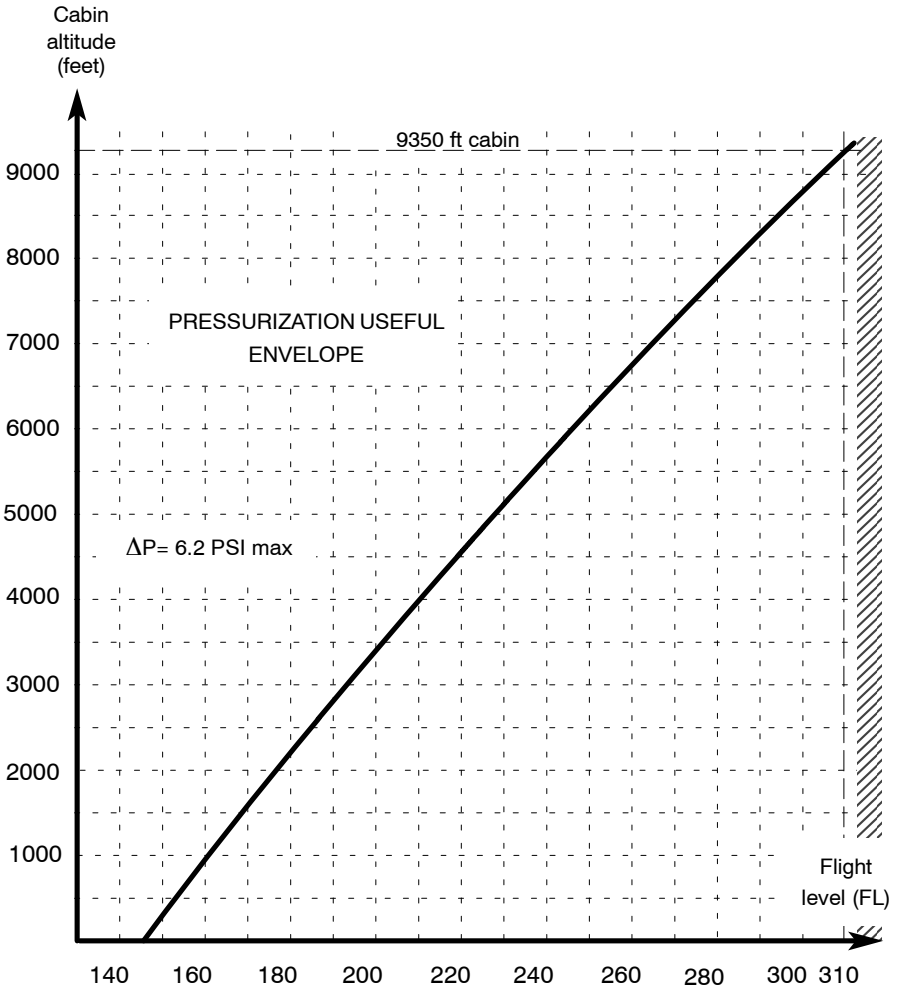

Figure 5.3.1 - CABIN PRESSURIZATION ENVELOPE

INTENTIONALLY LEFT BLANK

5.4 - SAT - IOAT CONVERSIONS

NOTE :

These indicated temperatures are available for stabilized cruise at normal operating power.

Pressure altitude (feet)	ISA - 20°C		ISA - 10°C		ISA		ISA + 10°C		ISA + 20°C	
	SAT	IOAT	SAT	IOAT	SAT	IOAT	SAT	IOAT	SAT	IOAT
SL	- 05	02	05	12	15	22	25	32	35	42
2000	- 09	- 02	01	08	11	18	21	28	31	38
4000	- 13	- 06	- 03	04	07	14	17	25	27	35
6000	- 17	- 10	- 07	00	03	11	13	21	23	31
8000	- 21	- 13	- 11	- 03	- 01	07	09	17	19	27
10000	- 25	- 17	- 15	- 07	- 05	03	05	13	15	23
12000	- 29	- 21	- 19	- 11	- 09	- 01	01	10	11	20
14000	- 33	- 25	- 23	- 14	- 13	- 04	- 03	06	07	16
16000	- 37	- 28	- 27	- 18	- 17	- 08	- 07	02	03	12
18000	- 41	- 32	- 31	- 22	- 21	- 12	- 11	- 01	- 01	08
20000	- 45	- 36	- 35	- 26	- 25	- 15	- 15	- 05	- 05	04
22000	- 48	- 39	- 38	- 29	- 28	- 19	- 18	- 09	- 08	00
24000	- 52	- 43	- 42	- 33	- 32	- 23	- 22	- 13	- 12	- 04
26000	- 56	- 47	- 46	- 36	- 36	- 27	- 26	- 17	- 16	- 08
28000	- 60	- 50	- 50	- 40	- 40	- 31	- 30	- 21	- 20	- 12
30000	- 64	- 54	- 54	- 45	- 44	- 35	- 34	- 26	- 24	- 16

Figure 5.4.1 - SAT - IOAT CONVERSIONS

INTENTIONALLY LEFT BLANK

5.5 - STALL SPEEDS

(Refer to Supplement 41 for TBM 700C2 airplane)

AIR-PLANE WEIGHT	CONFIG.		BANK											
	FLIGHT IDLE		0°			30°			45°			60°		
	LDG GR	Flaps	KIAS	KCAS	MPH IAS	KIAS	KCAS	MPH IAS	KIAS	KCAS	MPH IAS	KIAS	KCAS	MPH IAS
4850 lbs (2200 kg)	UP	UP	65	66	75	70	71	81	78	79	90	91	93	105
	DN	TO	62	63	71	67	68	77	73	75	84	87	89	100
	DN	LDG	53	53	61	57	57	66	63	63	73	75	75	86
5512 lbs (2500 kg)	UP	UP	70	71	81	75	76	86	82	84	94	98	100	113
	DN	TO	66	67	76	71	72	82	78	80	90	93	95	107
	DN	LDG	57	57	66	61	61	70	68	68	78	81	81	93
6579 lbs (2984 kg)	UP	UP	75	76	86	80	82	92	88	90	101	105	107	121
	DN	TO	71	72	82	75	77	86	84	86	97	100	102	115
	DN	LDG	61	61	70	66	66	76	73	73	84	86	86	99

Figure 5.5.1 - STALL SPEEDS

INTENTIONALLY LEFT BLANK

5.6 - WIND COMPONENTS

EXAMPLE : Angle between wind direction and flight path : 50°
 Headwind : 8 kts
 Crosswind : 10 kts
 Wind speed : 13 kts

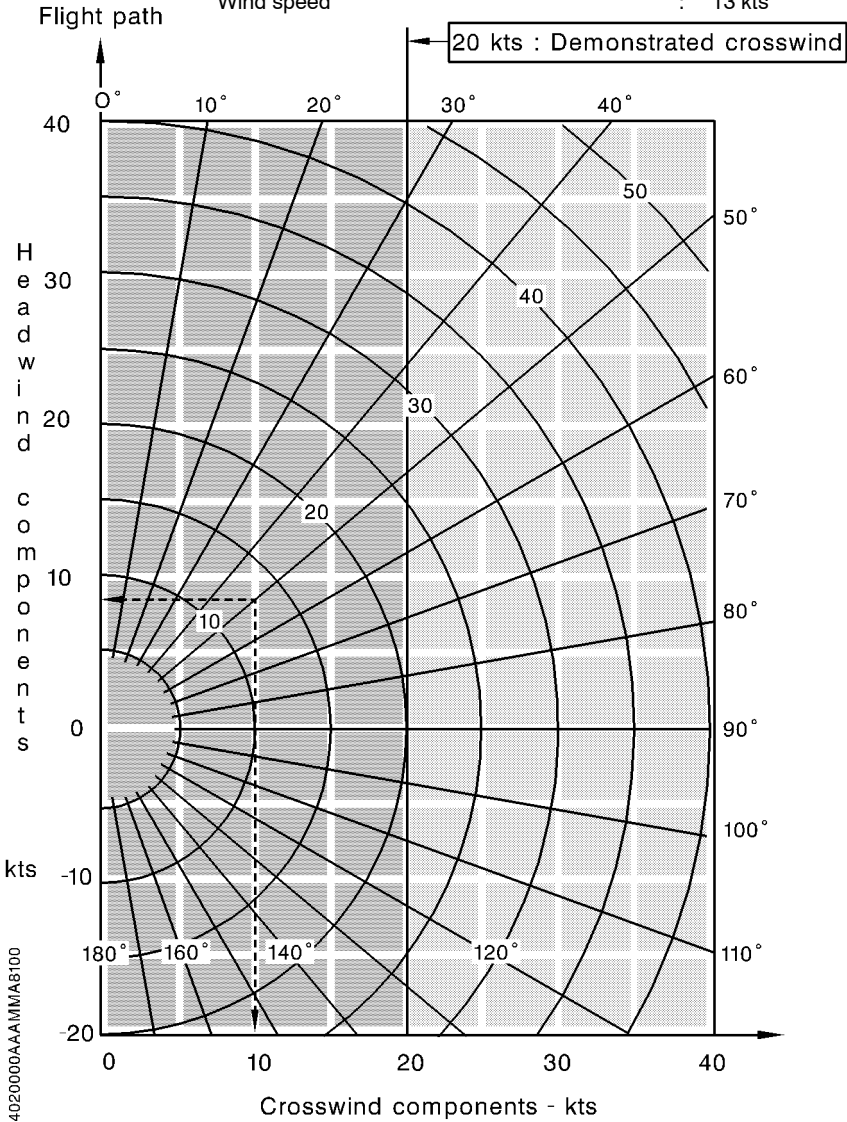

Figure 5.6.1 - WIND COMPONENTS

INTENTIONALLY LEFT BLANK

5.7 - ENGINE OPERATION

The following tables must be used during normal operation of the airplane.

The following conditions are given :

- $N_p = 2000$ RPM,
- BLEED ON.

The torque must be set at or below the value corresponding to the local conditions of flight level and temperature.

Example : for FL = 260 and IOAT = - 25°C, the following tables give the maximum torque to be set.

Maximum climb power : TRQ = 84 % for IAS = 130 KIAS
(Add 1 % of TRQ for each additional
15 KIAS on climb airspeed)
(cf. tables Figures 5.7.1A and 5.7.1B)

Maximum cruise power : TRQ = 98 %
(cf. tables Figures 5.7.2A and 5.7.2B)

- Recommended cruise power : TRQ = 92 %
(cf. tables Figures 5.7.3A and 5.7.3B)

CAUTION

**THE TRQ SETTING MUST NEVER EXCEED 100 % FOR
NP = 2000 RPM**

REMARK :

The engine ITT limit at 800°C during continuous operation may be used in case of operational need. However, in order to ensure a good engine aging, an ITT limit at 785°C is recommended during continuous operation (climb and cruise).

ENGINE OPERATION

Conditions : **Maximum climb power (FL ≤ 200)** ISA

Landing gear and flaps UP

IAS = 130 KIAS - Np = 2000 RPM - BLEED ON

NOTE :

Add 1 % of TRQ for each additional 10 KCAS on climb airspeed

T° (°C)		FLIGHT LEVEL (FL)										
SAT	IOAT	100	110	120	130	140	150	160	170	180	190	200
-25	-19											
-23	-17											
-21	-15											
-19	-13											100
-17	-11											99
-15	-09											97
-13	-07										100	95
-11	-05										98	93
-09	-03									100	96	91
-07	-01									99	94	89
-05	+01								100	97	92	87
-03	+03								99	95	90	85
-01	+05								97	93	87	82
+01	+07							100	95	90	85	80
+03	+09							98	93	88	82	78
+05	+11						100	95	91	86	80	75
+07	+13						98	93	88	83	78	72
+09	+15					100	95	90	86	81	74	69
+11	+17				100	97	93	88	83	78	71	66
+13	+19				99	95	90	85	80	74	69	
+15	+21			100	97	92	88	82	77	71		
+17	+23			99	94	90	84	79	67			
+19	+25		100	96	92	86	81	67				
+21	+27		98	94	88	83	68					
+23	+29	100	96	90	76	67						
+25	+31	97	84	76	67							
+27	+33	84	75	67								
+29	+35	74	68									
+31	+37	69										

CAUTION

THE TRQ SETTING MUST NEVER EXCEED 100 % FOR Np = 2000 RPM

Figure 5.7.1A - ENGINE OPERATION
[Maximum climb power (FL ≤ 200)]

ENGINE OPERATION

Conditions : **Maximum climb power (FL ≥ 200)** ISA

Landing gear and flaps UP

IAS = 130 KIAS - Np = 2000 RPM - BLEED ON

NOTE :

Add 1 % of TRQ for each additional 10 KCAS on climb airspeed

T° (°C)		FLIGHT LEVEL (FL)											
SAT	IOAT	200	210	220	230	240	250	260	270	280	290	300	310
-67	-60												91
-65	-58										100	94	89
-63	-56										97	92	86
-61	-54									100	95	90	85
-59	-52									99	93	88	83
-57	-50									97	91	85	81
-55	-48								100	94	89	84	79
-53	-46								98	92	87	82	77
-51	-44							100	95	90	85	80	75
-49	-42							99	93	88	83	79	74
-47	-40							97	92	87	82	77	73
-45	-38						100	95	90	85	80	76	72
-43	-36						98	93	88	83	79	75	70
-41	-34						97	92	87	82	78	73	69
-39	-32					100	95	90	85	81	76	72	67
-37	-30					98	94	89	84	79	74	70	65
-35	-28					97	92	87	82	77	73	68	64
-33	-26				100	95	91	86	81	76	71	66	62
-31	-25				99	94	89	84	79	74	69	65	61
-29	-23				97	92	87	82	77	72	68	63	59
-27	-21			100	95	90	85	80	75	70	66	61	57
-25	-19			98	93	88	83	78	73	69	64	59	55
-23	-17		100	95	91	86	81	76	71	67	62	58	54
-21	-15		98	94	89	84	79	74	70	65	60	57	53
-19	-13	100	96	92	87	82	77	73	68	63	59	55	
-17	-11	99	94	90	85	80	75	71	66	61	57	53	
-15	-09	97	92	88	83	78	74	69	64	59	55		
-13	-07	95	90	86	81	76	72	67	62	57	53		
-11	-05	93	88	84	79	74	70	65	60	55			
-09	-03	91	86	82	77	72	68	63	58	53			
-07	-01	89	84	80	75	70	65	60	56				
-05	+01	87	82	77	73	68	63	58	54				
-03	+03	85	80	75	70	66	60	55					
-01	+05	82	78	73	68	63	57	53					
+01	+07	80	75	70	65	60	55						
+03	+09	78	73	67	62	57							
+05	+11	75	70	65	59								
+07	+13	72	67	62									
+09	+15	69	64										
+11	+17	66											

CAUTION

THE TRQ SETTING MUST NEVER EXCEED 100 % FOR Np = 2000 RPM

Figure 5.7.1B - ENGINE OPERATION
[Maximum climb power (FL ≥ 200)]

ENGINE OPERATION

Conditions : **Maximum cruise power (FL ≤ 200)** ISA

Landing gear and flaps UP
Np = 2000 RPM - BLEED ON

NOTE :

Use preferably recommended cruise power

T° (°C)		FLIGHT LEVEL (FL)											
		SAT	IOAT	100	110	120	130	140	150	160	170	180	190
-25	-15												
-23	-13												
-21	-11												
-19	-09												
-17	-07												
-15	-05												
-13	-03												
-11	-02												
-09	00												100
-07	+02												99
-05	+04												97
-03	+06											100	95
-01	+08											98	93
+01	+10										100	95	91
+03	+12										98	93	88
+05	+14									100	96	91	85
+07	+16									98	93	88	82
+09	+18								100	96	91	84	78
+11	+20								98	93	87	81	75
+13	+22								97	91	85	79	
+15	+24							100	93	87	82		
+17	+26						100	96	90	84			
+19	+28						98	92	86				
+21	+29				100	95	89						
+23	+31			100	97	84							
+25	+33		100	92	84								
+27	+35	100	92	83									
+29	+37	91	83										
+31	+39	82											

CAUTION

THE TRQ SETTING MUST NEVER EXCEED 100 % FOR Np = 2000 RPM

Figure 5.7.2A - ENGINE OPERATION
[Maximum cruise power (FL ≤ 200)]

ENGINE OPERATION

Conditions : **Maximum cruise power (FL ≥ 200)** ISA

Landing gear and flaps UP

Np = 2000 RPM - BLEED ON

NOTE :

Use preferably recommended cruise power

T° (°C)		FLIGHT LEVEL (FL)											
SAT	IOAT	200	210	220	230	240	250	260	270	280	290	300	310
-67	-56												100
-65	-54												99
-63	-52												97
-61	-50											100	95
-59	-48											98	93
-57	-46										100	96	91
-55	-44										98	94	89
-53	-42										97	92	87
-51	-40									100	95	90	85
-49	-38									98	93	88	83
-47	-36									97	91	86	81
-45	-34								100	95	89	84	79
-43	-32								99	93	88	82	77
-41	-30								97	91	86	80	75
-39	-28							100	95	90	84	79	74
-37	-26							99	93	88	82	77	72
-35	-24							97	91	86	81	75	70
-33	-22						100	95	89	84	79	73	68
-31	-20						98	93	88	82	77	71	66
-29	-19						96	91	86	80	75	69	64
-27	-17					100	94	89	84	78	73	67	62
-25	-15					98	92	87	82	76	71	66	60
-23	-13				100	96	90	85	80	74	69	64	59
-21	-11				98	94	88	83	78	72	67	62	57
-19	-09				97	92	86	81	76	70	65	61	
-17	-07			100	95	90	84	79	74	68	63	59	
-15	-05			98	93	88	82	77	72	66	61	57	
-13	-03		100	96	91	86	80	74	69	64	59	55	
-11	-02		98	94	88	84	78	72	67	62	57	53	
-09	00	100	96	92	86	81	75	70	65	59	54	51	
-07	+02	99	94	89	84	79	73	67	62	56	52		
-05	+04	97	92	87	81	77	71	65	59	54			
-03	+06	95	90	85	79	74	68	62	56				
-01	+08	93	87	82	76	71	65	60					
+01	+10	91	85	80	73	69	62						
+03	+12	88	82	77	71	66							
+05	+14	85	79	74	68								
+07	+16	82	76	72									
+09	+18	78	73										
+11	+20	75											

CAUTION

THE TRQ SETTING MUST NEVER EXCEED 100 % FOR Np = 2000 RPM

Figure 5.7.2B - ENGINE OPERATION
[Maximum cruise power (FL ≥ 200)]

ENGINE OPERATION

Conditions : **Normal (recommended) cruise power (FL ≤ 200)** ISA
Landing gear and flaps UP
Np = 2000 RPM - BLEED ON

T° (°C)		FLIGHT LEVEL (FL)											
SAT	IOAT	100	110	120	130	140	150	160	170	180	190	200	
-25	-15												
-23	-13												
-21	-11												
-19	-09												
-17	-07												
-15	-05											100	
-13	-03											98	
-11	-02											96	
-09	00										100	94	
-07	+02										98	92	
-05	+04									100	96	90	
-03	+06									99	93	87	
-01	+08								100	96	91	85	
+01	+10								98	93	88	82	
+03	+12							100	95	90	85	79	
+05	+14							98	93	88	83	76	
+07	+16						100	95	90	85	81	74	
+09	+18						98	93	88	83	78	71	
+11	+20					100	95	90	86	80	74	67	
+13	+22					98	93	88	82	76	62		
+15	+24				100	95	91	85	72	63			
+17	+26			100	97	93	84	72	63				
+19	+28		100	99	95	81	72	64					
+21	+29	100	94	88	80	72	64						
+23	+31	93	88	80	72	65							
+25	+33	87	79	71	66								
+27	+35	79	73	67									
+29	+37	74	69										
+31	+39	70											

CAUTION

THE TRQ MUST NEVER EXCEED 100 % FOR Np = 2000 RPM

Figure 5.7.3A - ENGINE OPERATION
[Normal (recommended) cruise power (FL ≤ 200)]

ENGINE OPERATION

Conditions : **Normal (recommended) cruise power (FL ≥ 200)** ISA
 Landing gear and flaps UP
 Np = 2000 RPM - BLEED ON

T° (°C)		FLIGHT LEVEL (FL)											
SAT	IOAT	200	210	220	230	240	250	260	270	280	290	300	310
-67	-56												95
-65	-54											100	93
-63	-52											98	91
-61	-50										100	95	89
-59	-48										98	93	87
-57	-46										96	90	85
-55	-44									100	94	88	83
-53	-42									98	92	86	81
-51	-41								100	96	90	84	79
-49	-39								99	94	88	82	77
-47	-37								97	92	86	80	75
-45	-35							100	95	90	85	78	73
-43	-33							99	94	88	83	76	71
-41	-31							97	92	86	81	75	70
-39	-29						100	95	90	84	79	74	69
-37	-27						98	94	87	82	77	72	67
-35	-25						97	92	85	80	75	69	65
-33	-23					100	95	90	83	78	73	67	63
-31	-21					98	93	88	81	76	71	66	61
-29	-19				100	96	91	86	79	74	69	64	59
-27	-17				98	94	89	83	77	72	67	62	57
-25	-15				96	92	87	81	75	70	65	60	56
-23	-13			100	94	90	85	79	73	68	63	58	54
-21	-12			98	92	87	83	76	71	66	61	57	52
-19	-10		100	96	90	85	80	74	69	64	59	55	
-17	-08		98	93	88	83	78	72	67	62	58	53	
-15	-06	100	96	91	86	81	76	70	65	60	56	51	
-13	-04	98	94	89	83	78	73	67	63	58	54	50	
-11	-02	96	92	87	81	76	71	65	60	56	52	48	
-09	00	94	89	84	78	74	69	63	58	54	50	46	
-07	+02	92	87	82	76	71	66	60	56	52	48		
-05	+04	90	84	79	74	68	64	58	54	50			
-03	+06	87	82	77	71	66	61	56	52				
-01	+08	85	79	74	68	63	58	53					
+01	+10	82	77	72	66	60	55						
+03	+12	79	74	69	63	58							
+05	+14	76	71	67	60								
+07	+16	74	68	64									
+09	+18	71	65										
+11	+20	67											

CAUTION
THE TRQ MUST NEVER EXCEED 100 % FOR Np = 2000 RPM

Figure 5.7.3B - ENGINE OPERATION
 [Normal (recommended) cruise power (FL ≥ 200)]

INTENTIONALLY LEFT BLANK

5.8 - TAKEOFF DISTANCES

(Refer to Supplement 41 for TBM 700C2 airplane)

WEIGHT : 5512 lbs (2500 kg)

- Associated conditions :
- Landing gear DN and flaps TO
 - 15° of attitude - TRQ = 100 %
 - Np = 2000 RPM - BLEED ON
 - Hard, dry and level runway
 - GR = Ground roll (in ft)
 - D₅₀ = Takeoff distance (clear to 50 ft) (in ft)
 - Rotation speed choice (V_R)

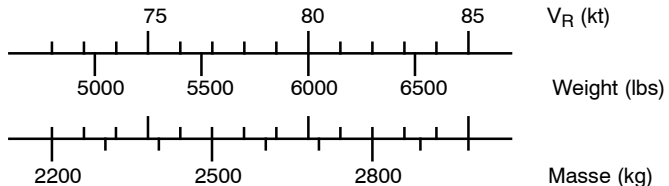

WEIGHT : 5512 lbs (2500 kg) At 50 ft = 91 KIAS - 105 MPH IAS								
PRESSURE ALTITUDE ft	ISA - 35°C		ISA - 20°C		ISA - 10°C		ISA	
	GR	D50	GR	D50	GR	D50	GR	D50
0	787	1280	886	1411	951	1493	1017	1591
2000	886	1411	984	1558	1066	1657	1132	1772
4000	984	1558	1099	1722	1181	1837	1280	1968
6000	1099	1722	1230	1903	1329	2051	1444	2215
8000	1230	1903	1394	2149	1526	2329	1657	2510
PRESSURE ALTITUDE ft	ISA + 10°C		ISA + 20°C		ISA + 30°C		ISA + 37°C	
	GR	D50	GR	D50	GR	D50	GR	D50
0	1083	1690	1148	1788	1214	1903	1247	1969
2000	1214	1870	1296	1985	1378	2133	1444	2231
4000	1363	2100	1476	2247	1575	2411	1640	2526
6000	1575	2379	1690	2559	1837	2756	1919	2887
8000	1804	2707	1968	2920	2100	3133	2198	3281

Figure 5.8.1 - TAKEOFF DISTANCES - 5512 lbs (2500 kg)

- Corrections :
- . Reduce total distances of 10 % every 10 kts of headwind
 - . Increase total distances of 30 % every 10 kts of tail-wind
 - . Increase by :

7 %	on hard sod	25 %	on high grass
10 %	on short grass	30 %	on slippery runway
15 %	on wet runway		

NOTE :

Between ISA + 30°C and ISA + 37°C, it may be necessary to cut-off the Bleed in order to set TRQ = 100 % during takeoff while respecting the engine limitations. In this case, reduce power after takeoff to set the Bleed ON.

TAKEOFF DISTANCES

WEIGHT : 6579 lbs (2984 kg)

- Associated conditions :
- Landing gear DN and flaps TO
 - 15° of attitude - TRQ = 100 %
 - Np = 2000 RPM - BLEED ON
 - Hard, dry and level runway
 - GR = Ground roll (in ft)
 - D₅₀ = Takeoff distance (clear to 50 ft) (in ft)
 - Rotation speed choice (V_R)

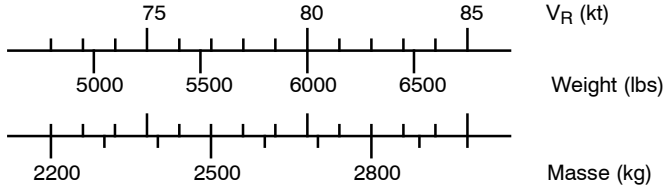

WEIGHT : 6579 lbs (2984 kg) At 50 ft = 94 KIAS - 108 MPH IAS								
PRESSURE ALTITUDE ft	ISA - 35°C		ISA - 20°C		ISA - 10°C		ISA	
	GR	D50	GR	D50	GR	D50	GR	D50
0	1083	1673	1214	1870	1280	2001	1378	2133
2000	1214	1870	1345	2067	1444	2198	1542	2362
4000	1345	2067	1509	2297	1640	2461	1739	2625
6000	1509	2297	1706	2559	1837	2723	1968	2920
8000	1706	2559	1903	2854	2067	3051	2231	3281
PRESSURE ALTITUDE ft	ISA + 10°C		ISA + 20°C		ISA + 30°C		ISA + 37°C	
	GR	D50	GR	D50	GR	D50	GR	D50
0	1476	2264	1575	2395	1690	2559	1755	2657
2000	1673	2493	1772	2657	1903	2854	1969	2953
4000	1870	2789	2001	2953	2149	3182	2231	3314
6000	2100	3117	2297	3346	2461	3609	2543	3740
8000	2428	3543	2657	3839	2854	4134	2969	4298

Figure 5.8.2 - TAKEOFF DISTANCES - 6579 lbs (2984 kg)

- Corrections :
- . Reduce total distances of 10 % every 10 kts of headwind
 - . Increase total distances of 30 % every 10 kts of tail-wind
 - . Increase by :

7 %	on hard sod	25 %	on high grass
10 %	on short grass	30 %	on slippery runway
15 %	on wet runway		

NOTE :

Between ISA + 30°C and ISA + 37°C, it may be necessary to cut-off the Bleed in order to set TRQ = 100 % during takeoff while respecting the engine limitations. In this case, reduce power after takeoff to set the Bleed ON.

5.9 - CLIMB PERFORMANCE

(Refer to Supplement 41 for TBM 700C2 airplane)

CLIMB SPEEDS (IAS = 130 KIAS)

Conditions : Maximum climb power
Landing gear and flaps UP
IAS = 130 KIAS - BLEED ON

Airplane weight	Pressure altitude (feet)	RATE OF CLIMB (ft/min)					
		ISA - 20°C	ISA - 10°C	ISA	ISA + 10°C	ISA + 20°C	ISA + 30°C
4850 lbs (2200 kg)	SL	3060	2920	2800	2690	2590	2480
	2000	3030	2890	2770	2660	2550	2455
	4000	3000	2860	2740	2630	2520	2415
	6000	2970	2830	2700	2590	2480	2380
	8000	2930	2800	2660	2550	2440	2340
5512 lbs (2500 kg)	SL	2600	2485	2380	2285	2190	2105
	2000	2570	2455	2350	2250	2160	2080
	4000	2540	2425	2320	2220	2130	2045
	6000	2510	2395	2290	2185	2090	2010
	8000	2480	2350	2250	2150	2035	1975
6579 lbs (2984 kg)	SL	2050	1955	1875	1795	1720	1640
	2000	2025	1925	1840	1765	1690	1620
	4000	1995	1900	1815	1735	1660	1585
	6000	1970	1870	1780	1700	1625	1555
	8000	1935	1840	1745	1665	1590	1520

Figure 5.9.1 - CLIMB SPEEDS (IAS = 130 KIAS)

CLIMB PERFORMANCE

CLIMB SPEEDS (IAS = 160 KIAS)

Conditions : Maximum climb power
 Landing gear and flaps UP
 IAS = 160 KIAS - BLEED ON

Airplane weight	Pressure altitude (feet)	RATE OF CLIMB (ft/min)					
		ISA - 20°C	ISA - 10°C	ISA	ISA + 10°C	ISA + 20°C	ISA + 30°C
4850 lbs (2200 kg)	SL	2680	2560	2440	2330	2220	2120
	2000	2640	2500	2390	2280	2180	2080
	4000	2590	2460	2340	2230	2130	2030
	6000	2550	2420	2290	2180	2080	1980
	8000	2500	2360	2240	2130	2030	1925
5512 lbs (2500 kg)	SL	2290	2180	2000	1980	1890	1805
	2000	2250	2135	2030	1940	1850	1765
	4000	2200	2090	1990	1895	1805	1725
	6000	2150	2050	1945	1845	1760	1680
	8000	2110	2000	1895	1795	1730	1625
6579 lbs (2984 kg)	SL	1820	1730	1650	1570	1490	1415
	2000	1780	1690	1600	1530	1460	1380
	4000	1740	1650	1560	1490	1410	1345
	6000	1700	1610	1520	1450	1370	1305
	8000	1660	1570	1480	1400	1330	1255

Figure 5.9.2 - CLIMB SPEEDS (IAS = 160 KIAS)

CLIMB PERFORMANCE

TIME, CONSUMPTION AND CLIMB DISTANCE (IAS = 130 KIAS)

Conditions : **ISA - 20°C**

Maximum climb power

Landing gear and flaps UP

IAS = 130 KIAS - 2000 RPM - BLEED ON

NOTE :

Time, consumption and distance from the 50 ft

Pressure altitude (feet)	WEIGHT 4850 lbs (2200 kg)					WEIGHT 5512 lbs (2500 kg)					WEIGHT 6579 lbs (2984 kg)				
	Time (min. s)	Consump.			Dist. (NM)	Time (min. s)	Consump.			Dist. (NM)	Time (min. s)	Consump.			Dist. (NM)
		l	kg	us gal			l	kg	us gal			l	kg	us gal	
SL	00.00	0	0	0	0	00.00	0	0	0	0	00.00	0	0	0	0
2000	00.45	4	3	1.1	1	00.45	4	3	1.1	2	01.00	5	4	1.3	2
4000	01.30	6	5	1.6	3	01.30	8	6	2.1	3	02.00	10	8	2.6	4
6000	02.00	10	7	2.6	4	02.15	11	9	2.9	5	03.00	14	11	3.7	6
8000	02.45	12	10	3.2	6	03.00	15	12	4.0	7	04.00	19	15	5	9
10000	03.15	15	12	4.0	7	04.00	18	14	4.8	9	05.00	23	18	6	11
12000	04.00	18	14	4.8	9	04.45	21	17	5.5	11	06.00	27	22	7.1	14
14000	04.45	21	17	5.5	11	05.30	25	19	6.6	13	07.15	32	25	8.5	16
16000	05.30	24	19	6.3	13	06.30	28	22	7.4	15	08.15	36	28	9.5	19
18000	06.00	27	21	7.1	15	07.15	31	25	8.2	17	09.30	40	32	10.6	22
20000	07.00	29	23	7.7	17	08.00	35	27	9.2	20	10.30	44	35	11.6	25
22000	07.45	32	25	8.5	19	09.00	38	30	10.0	22	11.45	49	38	12.9	29
24000	08.30	35	27	9.3	21	10.00	41	32	10.8	25	13.00	53	42	14	32
26000	09.15	37	29	9.8	23	11.00	44	35	11.6	28	14.00	57	45	15.1	36
28000	10.00	40	32	10.6	26	12.00	48	37	12.7	31	15.30	62	49	16.4	40
30000	11.00	43	34	11.4	28	13.00	51	40	13.5	34	16.45	67	52	17.7	45
31000	11.24	45	35	12.0	31	13.34	54	42	14.0	37	17.48	70	55	19.0	48

Figure 5.9.3 - TIME, CONSUMPTION AND CLIMB DISTANCE
(IAS = 130 KIAS) / ISA - 20°C

CLIMB PERFORMANCE

TIME, CONSUMPTION AND CLIMB DISTANCE (IAS = 130 KIAS)

Conditions : **ISA**

Maximum climb power

Landing gear and flaps UP

IAS = 130 KIAS - 2000 RPM - BLEED ON

NOTE :

Time, consumption and distance from the 50 ft

Pressure altitude (feet)	WEIGHT 4850 lbs (2200 kg)					WEIGHT 5512 lbs (2500 kg)					WEIGHT 6579 lbs (2984 kg)				
	Time (min. s)	Consump.			Dist. (NM)	Time (min. s)	Consump.			Dist. (NM)	Time (min. s)	Consump.			Dist. (NM)
		l	kg	us gal			l	kg	us gal			l	kg	us gal	
SL	00.00	0	0	0	0	00.00	0	0	0	0	00.00	0	0	0	0
2000	00.45	4	3	1.1	2	00.45	4	3	1.1	2	01.00	5	4	1.3	2
4000	01.30	7	6	1.8	3	01.45	8	7	2.1	4	02.15	11	9	2.9	5
6000	02.15	11	8	2.9	5	02.30	12	10	3.2	6	03.15	16	13	4.2	7
8000	03.00	14	11	3.7	7	03.30	16	13	4.2	8	04.30	21	17	5.5	10
10000	03.45	17	14	4.5	8	04.15	20	16	5.3	10	05.30	26	20	6.9	13
12000	04.30	20	16	5.3	10	05.15	24	19	6.3	12	06.45	31	24	8.2	16
14000	05.00	24	19	6.3	12	06.15	28	22	7.4	15	08.00	36	28	9.5	19
16000	06.00	27	21	7.1	14	07.00	32	25	8.5	17	09.00	41	32	10.8	22
18000	06.45	30	23	7.9	17	08.00	35	28	9.2	20	10.30	46	36	12.2	26
20000	07.30	33	26	8.7	19	09.00	39	31	10.3	23	11.45	50	40	13.2	29
22000	08.30	36	28	9.5	21	10.00	43	34	11.4	26	13.00	55	43	14.5	33
24000	09.15	39	31	10.3	24	11.00	47	37	12.4	29	14.30	60	47	15.9	38
26000	10.15	43	33	11.4	27	12.15	51	40	13.5	33	16.00	66	52	17.4	43
28000	11.30	46	36	12.1	31	13.45	55	43	14.5	37	18.00	72	57	19	49
30000	12.45	50	39	13.2	36	15.30	60	47	15.9	43	20.30	79	62	20.9	58
31000	13.48	53	42	14.0	39	16.39	64	50	17.0	48	22.33	85	67	23.0	65

Figure 5.9.4 - TIME, CONSUMPTION AND CLIMB DISTANCE
(IAS = 130 KIAS) / ISA

CLIMB PERFORMANCE

TIME, CONSUMPTION AND CLIMB DISTANCE (IAS = 130 KIAS)

Conditions : **ISA + 20°C**
 Maximum climb power
 Landing gear and flaps UP
 IAS = 130 KIAS - 2000 RPM - BLEED ON

NOTE :

Time, consumption and distance from the 50 ft

Pressure altitude (feet)	WEIGHT 4850 lbs (2200 kg)					WEIGHT 5512 lbs (2500 kg)					WEIGHT 6579 lbs (2984 kg)				
	Time (min. s)	Consump.			Dist. (NM)	Time (min. s)	Consump.			Dist. (NM)	Time (min. s)	Consump.			Dist. (NM)
		l	kg	us gal			l	kg	us gal			l	kg	us gal	
SL	00.00	0	0	0	0	00.00	0	0	0	0	00.00	0	0	0	0
2000	00.45	4	3	1.0	2	01.00	5	4	1.3	2	01.15	6	5	1.6	3
4000	01.30	8	6	2.1	4	01.45	9	7	2.4	4	02.15	12	10	3.2	5
6000	02.15	12	9	3.2	5	02.45	14	11	3.7	6	03.30	18	14	4.8	8
8000	03.00	16	12	4.2	7	03.45	18	14	4.8	9	04.45	24	19	6.3	11
10000	04.00	19	15	5.0	9	04.45	23	18	6.1	11	06.00	29	23	7.7	15
12000	05.00	23	18	6.1	12	05.45	27	21	7.1	14	07.30	35	27	9.2	18
14000	05.45	26	21	6.9	14	06.45	31	24	8.2	17	08.45	40	32	10.6	22
16000	06.30	30	23	7.9	16	07.45	35	28	9.2	19	10.00	46	36	12.2	25
18000	07.30	34	26	9.0	19	08.45	40	31	10.6	23	11.30	52	40	13.7	30
20000	08.30	37	29	9.8	22	10.00	44	35	11.6	27	13.15	58	45	15.3	35
22000	09.45	41	32	10.8	26	11.30	49	39	12.9	31	15.15	64	50	16.9	41
24000	11.00	45	36	11.9	30	13.00	54	43	14.3	36	17.30	72	56	19	48
26000	12.30	50	39	13.2	35	15.00	60	47	15.9	43	20.30	80	63	21.1	58
28000	14.30	55	43	14.5	42	17.30	67	52	17.7	51	24.30	91	72	24	72
30000	17.00	62	48	16.4	51	21.00	75	59	19.8	63	30.30	107	84	28.3	94
31000	19.25	68	53	18.0	60	24.35	84	66	22.0	77	40.50	130	102	34.0	129

Figure 5.9.5 - TIME, CONSUMPTION AND CLIMB DISTANCE
(IAS = 130 KIAS) / ISA + 20°C

CLIMB PERFORMANCE

TIME, CONSUMPTION AND CLIMB DISTANCE (IAS = 160 KIAS)

Conditions : **ISA - 20°C**

Maximum climb power

Landing gear and flaps UP

IAS = 160 KIAS up to 20000 ft ; - 2 KIAS / 1000 ft then

2000 RPM - BLEED ON

NOTE :

Time, consumption and distance from the 50 ft

Pressure altitude (feet)	WEIGHT 4850 lbs (2200 kg)					WEIGHT 5512 lbs (2500 kg)					WEIGHT 6579 lbs (2984 kg)				
	Time (min. s)	Consump.			Dist. (NM)	Time (min. s)	Consump.			Dist. (NM)	Time (min. s)	Consump.			Dist. (NM)
		l	kg	us gal			l	kg	us gal			l	kg	us gal	
SL	00.00	0	0	0	0	00.00	0	0	0	0	00.00	0	0	0	0
2000	00.45	4	3	1.1	2	01.00	4	3	1.1	2	01.00	6	4	1.6	3
4000	01.30	7	5	1.8	4	01.45	9	7	2.4	5	02.15	11	9	2.9	6
6000	02.15	11	9	2.9	6	02.45	13	10	3.4	7	03.30	16	13	4.2	9
8000	03.00	14	11	3.7	8	03.30	17	13	4.5	10	04.30	21	17	5.5	12
10000	04.00	18	14	4.8	11	04.30	21	16	5.5	13	05.45	27	21	7.1	16
12000	04.45	21	17	5.5	13	05.30	25	20	6.6	15	07.00	32	25	8.5	20
14000	05.30	25	19	6.6	16	06.30	29	23	7.7	19	08.15	37	29	9.8	24
16000	06.30	28	22	7.4	18	07.30	33	26	8.7	22	09.30	42	33	11.1	28
18000	07.15	31	25	8.2	21	08.30	37	29	9.8	25	11.00	47	37	12.4	32
20000	08.15	35	27	9.2	24	09.45	41	32	10.8	29	12.30	52	41	13.7	37
22000	09.00	38	30	10.0	28	10.45	45	35	11.9	33	13.45	58	45	15.3	42
24000	10.00	41	32	10.8	31	12.00	49	39	12.9	37	15.15	63	49	16.6	47
26000	11.00	45	35	11.9	34	13.00	53	41	14.0	41	16.45	68	53	18	53
28000	12.00	48	37	12.7	37	14.00	56	44	14.8	44	18.15	73	57	19.3	58
30000	13.00	51	40	13.5	41	15.00	60	47	15.9	48	19.45	78	61	20.6	63
31000	13.27	53	42	14.0	43	15.59	63	50	17.0	51	20.52	82	64	22.0	67

Figure 5.9.6 - TIME, CONSUMPTION AND CLIMB DISTANCE
(IAS = 160 KIAS) / ISA - 20°C

CLIMB PERFORMANCE

TIME, CONSUMPTION AND CLIMB DISTANCE (IAS = 160 KIAS)

Conditions : **ISA**

Maximum climb power

Landing gear and flaps UP

IAS = 160 KIAS up to 20000 ft ; - 2 KIAS / 1000 ft then

2000 RPM - BLEED ON

NOTE :

Time, consumption and distance from the 50 ft

Pressure altitude (feet)	WEIGHT 4850 lbs (2200 kg)					WEIGHT 5512 lbs (2500 kg)					WEIGHT 6579 lbs (2984 kg)				
	Time (min. s)	Consump.			Dist. (NM)	Time (min. s)	Consump.			Dist. (NM)	Time (min. s)	Consump.			Dist. (NM)
		l	kg	us gal			l	kg	us gal			l	kg	us gal	
SL	00.00	0	0	0	0	00.00	0	0	0	0	00.00	0	0	0	0
2000	00.45	4	3	1.1	2	01.00	5	4	1.3	3	01.15	6	5	1.6	3
4000	01.30	8	6	2.1	4	02.00	10	8	2.6	5	02.30	12	10	3.2	7
6000	02.30	12	10	3.2	7	03.00	14	11	3.7	8	03.45	18	15	4.8	10
8000	03.30	16	13	4.2	10	04.00	19	15	5.0	11	05.00	24	19	6.3	14
10000	04.30	20	16	5.3	12	05.00	24	19	6.3	14	06.30	30	24	7.9	18
12000	05.15	24	19	6.3	15	06.00	28	22	7.4	18	08.00	36	28	9.5	23
14000	06.15	28	22	7.4	18	07.15	33	26	8.7	21	09.15	42	33	11.1	28
16000	07.15	32	25	8.5	21	08.30	37	29	9.8	25	10.45	48	38	12.7	33
18000	08.15	36	28	9.5	25	09.45	42	33	11.1	29	12.30	54	42	14.3	38
20000	09.15	40	31	10.6	29	11.00	47	37	12.4	34	14.00	60	47	15.9	44
22000	10.15	44	34	11.6	32	12.00	52	41	13.7	39	15.45	67	52	17.7	50
24000	11.15	47	37	12.4	36	13.30	56	44	14.8	44	17.30	73	57	19.3	56
26000	12.30	51	40	13.5	41	15.00	62	49	16.4	50	19.30	79	62	20.9	64
28000	14.00	56	44	14.8	46	16.30	66	52	17.4	55	21.45	87	68	23.0	72
30000	15.30	60	47	15.8	52	18.30	72	57	19.0	62	24.30	95	75	25.1	83
31000	16.37	64	50	17.0	56	20.02	77	60	20.0	68	27.07	103	81	27.0	92

Figure 5.9.7 - TIME, CONSUMPTION AND CLIMB DISTANCE
(IAS = 160 KIAS) / ISA

CLIMB PERFORMANCE

TIME, CONSUMPTION AND CLIMB DISTANCE (IAS = 160 KIAS)

Conditions : **ISA + 20°C**

Maximum climb power

Landing gear and flaps UP

IAS = 160 KIAS up to 20000 ft ; - 2 KIAS / 1000 ft then

2000 RPM - BLEED ON

NOTE :

Time, consumption and distance from the 50 ft

Pressure altitude (feet)	WEIGHT 4850 lbs (2200 kg)					WEIGHT 5512 lbs (2500 kg)					WEIGHT 6579 lbs (2984 kg)				
	Time (min. s)	Consump.			Dist. (NM)	Time (min. s)	Consump.			Dist. (NM)	Time (min. s)	Consump.			Dist. (NM)
		l	kg	us gal			l	kg	us gal			l	kg	us gal	
SL	00.00	0	0	0	0	00.00	0	0	0	0	00.00	0	0	0	0
2000	01.00	5	4	1.3	3	01.00	5	4	1.3	3	01.15	7	6	1.8	4
4000	01.45	9	7	2.4	5	02.15	11	8	2.9	6	02.45	14	11	3.7	8
6000	02.45	14	11	3.7	8	03.15	16	13	4.2	9	04.15	21	16	5.5	12
8000	03.45	18	14	4.8	11	04.30	21	17	5.5	13	05.30	28	22	7.4	16
10000	04.45	23	18	6.1	14	05.30	27	21	7.1	17	07.15	34	27	9.0	21
12000	05.45	27	21	7.1	17	06.45	32	25	8.5	21	08.45	41	32	10.8	26
14000	06.45	32	25	8.5	21	08.00	37	29	9.8	25	10.15	48	38	12.7	32
16000	08.00	36	28	9.5	25	09.30	43	33	11.4	29	12.00	55	43	14.5	38
18000	09.00	41	32	10.8	29	11.00	48	38	12.7	35	14.00	62	49	16.4	45
20000	10.30	46	36	12.2	34	12.30	55	43	14.5	41	16.15	71	56	18.8	53
22000	12.15	52	41	13.7	41	14.30	62	49	16.4	49	19.15	81	63	21.4	64
24000	14.15	58	45	15.3	48	17.00	69	54	18.2	58	22.45	92	72	24.3	78
26000	16.30	65	51	17.2	57	20.00	78	61	20.6	69	27.30	106	83	28.0	96
28000	19.15	72	56	19.0	68	23.45	88	69	23.2	84	34.00	124	98	32.8	123
30000	23.00	82	64	21.7	83	29.00	102	80	26.9	105	46.00	155	121	41.0	170
31000	26.06	90	70	24.0	94	34.05	115	90	30.0	124	69.31	212	166	56.0	259

Figure 5.9.8 - TIME, CONSUMPTION AND CLIMB DISTANCE
(IAS = 160 KIAS) / ISA + 20°C

CLIMB PERFORMANCE

CLIMB PERFORMANCE AFTER GO-AROUND

Conditions : Maximum climb power
Landing gear DN and flaps LDG
IAS = 90 KIAS

Airplane weight	Pressure altitude (feet)	RATE OF CLIMB (ft/min)						
		ISA - 35°C	ISA - 20°C	ISA - 10°C	ISA	ISA + 10°C	ISA + 20°C	ISA + 30°C
4850 lbs (2200 kg)	SL	2270	2100	2000	1910	1820	1740	1650
	2000	2240	2070	1960	1870	1780	1695	1620
	4000	2200	2030	1920	1830	1730	1650	1570
	6000	2160	1980	1880	1780	1690	1600	1520
	8000	2120	1940	1830	1730	1630	1545	1465
5512 lbs (2500 kg)	SL	1900	1750	1660	1580	1500	1435	1355
	2000	1860	1720	1630	1550	1470	1395	1330
	4000	1820	1680	1590	1500	1430	1350	1285
	6000	1790	1630	1550	1460	1380	1305	1235
	8000	1750	1590	1500	1410	1330	1255	1185
6579 lbs (2984 kg)	SL	1410	1300	1230	1165	1105	1045	985
	2000	1380	1265	1195	1130	1065	1010	955
	4000	1345	1230	1155	1090	1025	970	915
	6000	1310	1190	1115	1050	985	925	870
	8000	1270	1145	1070	1000	940	880	825

Figure 5.9.9 - CLIMB PERFORMANCE AFTER GO-AROUND

CLIMB PERFORMANCE

CLIMB PERFORMANCE - FLAPS TO

Conditions : Climb maximum power
Landing gear UP and flaps TO
IAS = 110 KIAS

Airplane weight	Pressure altitude (feet)	RATE OF CLIMB (ft/min)						
		ISA - 35°C	ISA - 20°C	ISA - 10°C	ISA	ISA + 10°C	ISA + 20°C	ISA + 30°C
4850 lbs (2200 kg)	SL	3170	2970	2850	2730	2620	2520	2410
	2000	3160	2950	2820	2700	2600	2490	2395
	4000	3140	2920	2800	2670	2570	2460	2365
	6000	3110	2900	2760	2650	2540	2430	2330
	8000	3080	2870	2740	2610	2500	2395	2295
5512 lbs (2500 kg)	SL	2710	2540	2430	2330	2230	2145	2050
	2000	2700	2520	2400	2300	2200	2120	2035
	4000	2680	2490	2380	2270	2180	2090	2005
	6000	2650	2460	2350	2250	2150	2060	1975
	8000	2620	2440	2320	2220	2120	2030	1940
6579 lbs (2984 kg)	SL	2140	2000	1910	1830	1750	1680	1600
	2000	2120	1975	1880	1800	1720	1650	1585
	4000	2100	1950	1860	1775	1700	1620	1555
	6000	2075	1925	1830	1750	1670	1595	1525
	8000	2050	1895	1805	1720	1640	1565	1495

Figure 5.9.10 - CLIMB PERFORMANCE - FLAPS TO

5.10 - CRUISE PERFORMANCE

■ (Refer to Supplement 41 for TBM 700C2 airplane)

Conditions : ISA
Weight 5512 lbs (2500 kg)

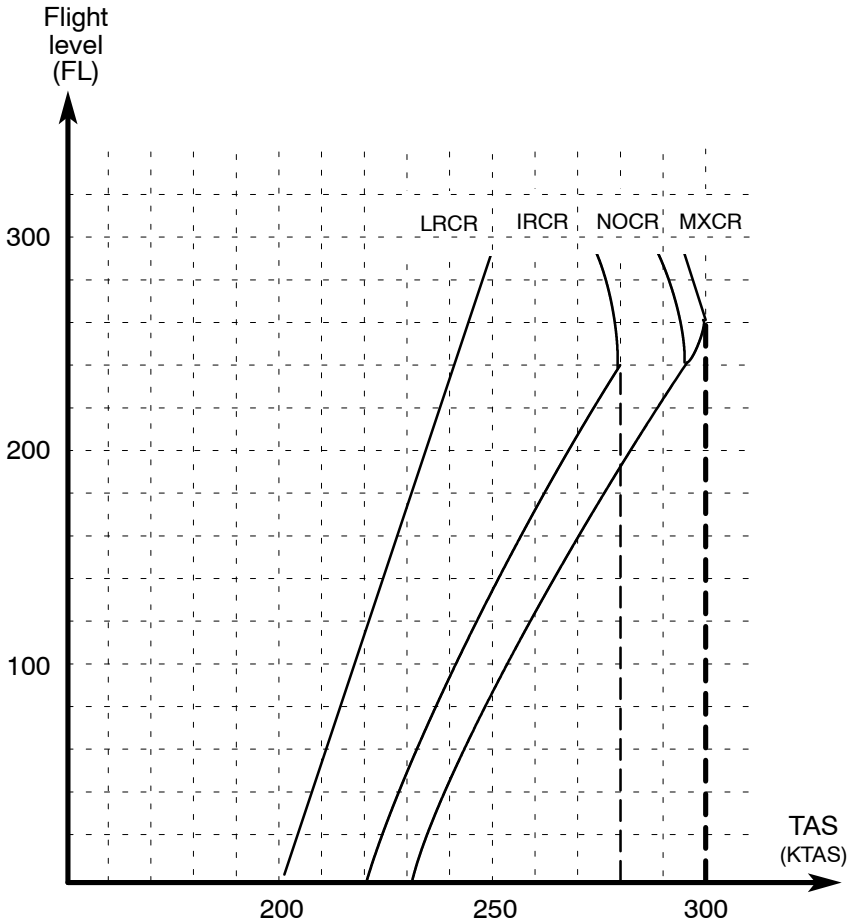

Figure 5.10.1 - CRUISE PERFORMANCE

CRUISE PERFORMANCE

Maximum cruise

Conditions : **ISA - 20°C**
Landing gear and flaps UP
2000 RPM (*) - BLEED ON

NOTE :
Use preferably recommended cruise power

Pressure altitude (feet)	IOAT (°C)	TRQ (%)	Fuel flow			AIRSPEEDS (kt)					
						4850 lbs (2200 kg)		5512 lbs (2500 kg)		6173 lbs (2800 kg)	
			l / h	kg / h	us gal / h	IAS	TAS	IAS	TAS	IAS	TAS
0	+ 2	100	304	239	80.3	231	226	230	225	229	224
5000	- 8	100	275	216	72.6	226	237	225	236	223	235
10000	- 17	100	250	196	66.0	221	249	220	248	218	246
15000	- 26	100	232	182	61.2	216	263	214	261	213	259
18000	- 32	100	223	175	58.9	213	271	211	269	210	267
20000	- 36	100	218	171	57.6	211	277	209	275	208	273
21000	- 37	100	216	170	57.1	210	280	208	278	207	276
22000	- 39	100	214	168	56.5	209	283	207	281	206	279
23000	- 41	100	212	166	56.0	208	286	206	284	205	282
24000	- 43	100	210	165	55.6	207	290	205	287	203	285
25000	- 45	100	209	164	55.3	206	293	204	291	202	288
26000	- 46	100	208	163	54.9	205	296	203	294	201	291
27000	- 48	100	207	162	54.7	204	300	202	297	200	294
28000	- 50	100	206	162	54.4	203	303	201	301	199	298
29000	- 52	100	206	161	54.3	202	307	200	304	198	301
30000	- 54	100	205	161	54.2	201	310	199	308	197	305
31000	- 56	100	206	161	54.3	200	314	198	311	196	308

Figure 5.10.2 - CRUISE PERFORMANCE -
Maximum cruise / ISA - 20°C

(*) Propeller RPM utilization between 1600 and 2000 RPM is possible without changing performance. Display the TRQ indicated in table with Np = 2000 RPM, then reduce Np without resetting power lever (within limits permitted by torque limiter).

CRUISE PERFORMANCE

Maximum cruise

Conditions : **ISA - 10°C**
Landing gear and flaps UP
2000 RPM (*) - BLEED ON

NOTE :
Use preferably recommended cruise power

Pressure altitude (feet)	IOAT (°C)	TRQ (%)	Fuel flow			AIRSPEEDS (kt)					
						4850 lbs (2200 kg)		5512 lbs (2500 kg)		6173 lbs (2800 kg)	
			l / h	kg / h	us gal / h	IAS	TAS	IAS	TAS	IAS	TAS
0	+ 12	100	308	242	81.4	229	228	228	227	227	226
5000	+ 2	100	279	219	73.6	224	240	223	238	222	237
10000	- 7	100	254	199	67.0	219	252	218	251	216	249
15000	- 16	100	234	184	61.9	214	266	213	264	211	262
18000	- 22	100	225	177	59.4	211	274	209	272	208	270
20000	- 25	100	220	173	58.2	209	281	207	278	206	276
21000	- 27	100	218	171	57.6	208	284	206	281	205	279
22000	- 29	100	216	170	57.1	207	287	205	285	204	282
23000	- 31	100	215	168	56.7	206	290	204	288	202	285
24000	- 33	100	213	167	56.3	205	293	203	291	201	288
25000	- 34	100	212	166	55.9	204	297	202	294	200	291
26000	- 36	100	210	165	55.6	203	300	201	298	199	295
27000	- 38	100	209	164	55.3	202	304	200	301	198	298
28000	- 40	100	209	164	55.2	201	307	199	305	197	302
29000	- 42	97	201	158	53.2	197	307	195	303	193	300
30000	- 44	93	194	152	51.2	193	306	190	301	188	298
31000	- 46	91	187	146	49.3	189	304	186	300	184	296

Figure 5.10.3 - CRUISE PERFORMANCE -
Maximum cruise / ISA - 10°C

(*) Propeller RPM utilization between 1600 and 2000 RPM is possible without changing performance. Display the TRQ indicated in table with Np = 2000 RPM, then reduce Np without resetting power lever (within limits permitted by torque limiter).

CRUISE PERFORMANCE

Maximum cruise

Conditions : **ISA - 5°C**
Landing gear and flaps UP
2000 RPM (*) - BLEED ON

NOTE :
Use preferably recommended cruise power

Pressure altitude (feet)	IOAT (°C)	TRQ (%)	Fuel flow			AIRSPEEDS (kt)					
						4850 lbs (2200 kg)		5512 lbs (2500 kg)		6173 lbs (2800 kg)	
			l / h	kg / h	us gal / h	IAS	TAS	IAS	TAS	IAS	TAS
0	+ 17	100	310	243	81.8	228	230	227	229	226	228
5000	+ 8	100	280	220	74.1	223	241	222	240	221	238
10000	- 2	100	255	200	67.4	218	254	217	252	216	250
15000	- 11	100	235	185	62.2	213	267	212	265	210	263
18000	- 17	100	226	178	59.8	210	276	208	274	207	272
20000	- 20	100	222	174	58.6	208	282	206	280	205	278
21000	- 22	100	220	173	58.1	207	285	205	283	204	281
22000	- 24	100	218	171	57.5	206	289	204	286	203	284
23000	- 26	100	216	170	57.1	205	292	203	289	202	287
24000	- 28	100	215	168	56.7	204	295	202	293	200	290
25000	- 29	100	213	167	56.3	203	298	201	296	199	293
26000	- 31	100	212	166	56.0	202	302	200	299	198	296
27000	- 33	99	210	165	55.5	200	304	198	301	196	299
28000	- 35	96	202	159	53.5	197	304	194	301	193	298
29000	- 37	92	195	153	51.5	193	303	190	300	188	296
30000	- 39	88	188	147	49.6	188	302	186	298	183	294
31000	- 41	86	181	142	47.7	184	300	182	296	179	292

Figure 5.10.4 - CRUISE PERFORMANCE -
Maximum cruise / ISA - 5°C

(*) Propeller RPM utilization between 1600 and 2000 RPM is possible without changing performance. Display the TRQ indicated in table with Np = 2000 RPM, then reduce Np without resetting power lever (within limits permitted by torque limiter).

CRUISE PERFORMANCE

Maximum cruise

Conditions : **ISA**
Landing gear and flaps UP
2000 RPM (*) - BLEED ON

NOTE :

Use preferably recommended cruise power

Pressure altitude (feet)	IOAT (°C)	TRQ (%)	Fuel flow			AIRSPEEDS (kt)					
						4850 lbs (2200 kg)		5512 lbs (2500 kg)		6173 lbs (2800 kg)	
			l / h	kg / h	us gal / h	IAS	TAS	IAS	TAS	IAS	TAS
0	+ 22	100	312	245	82.3	228	231	227	230	226	229
5000	+ 13	100	282	221	74.5	223	243	221	241	220	240
10000	+ 3	100	257	201	67.8	217	255	216	253	215	252
15000	- 6	100	237	186	62.5	212	269	211	267	209	265
18000	- 12	100	228	179	60.2	209	278	208	275	206	273
20000	- 15	100	223	175	58.9	207	284	205	281	204	279
21000	- 17	100	221	174	58.5	206	287	204	285	203	282
22000	- 19	100	220	172	58.0	205	290	203	288	202	285
23000	- 21	100	218	171	57.5	204	293	202	291	201	289
24000	- 22	100	216	170	57.1	203	297	201	294	199	292
25000	- 24	100	215	169	56.8	202	300	200	298	198	295
26000	- 26	99	209	164	55.2	200	303	198	300	197	298
27000	- 28	95	202	159	53.5	196	302	194	298	193	297
28000	- 30	91	195	153	51.6	192	301	189	297	188	295
29000	- 32	88	188	148	49.8	188	299	186	296	184	293
30000	- 34	84	181	142	47.9	184	298	182	294	178	288
31000	- 36	81	174	136	45.9	180	296	177	292	174	287

Figure 5.10.5 - CRUISE PERFORMANCE -
Maximum cruise / ISA

(*) Propeller RPM utilization between 1600 and 2000 RPM is possible without changing performance. Display the TRQ indicated in table with Np = 2000 RPM, then reduce Np without resetting power lever (within limits permitted by torque limiter).

CRUISE PERFORMANCE

Maximum cruise

Conditions : **ISA + 5°C**
Landing gear and flaps UP
2000 RPM (*) - BLEED ON

NOTE :

Use preferably recommended cruise power

Pressure altitude (feet)	IOAT (°C)	TRQ (%)	Fuel flow			AIRSPEEDS (kt)					
						4850 lbs (2200 kg)		5512 lbs (2500 kg)		6173 lbs (2800 kg)	
			l / h	kg / h	us gal / h	IAS	TAS	IAS	TAS	IAS	TAS
0	+ 27	100	313	246	82.8	227	232	226	231	225	230
5000	+ 18	100	283	223	74.9	222	244	221	243	219	241
10000	+ 8	100	258	202	68.1	217	256	215	255	214	253
15000	- 1	100	238	187	62.9	211	270	210	268	208	267
18000	- 6	100	229	180	60.6	208	279	207	277	205	275
20000	- 10	100	224	176	59.3	206	285	204	283	203	281
21000	- 12	100	223	175	58.9	205	288	203	286	202	284
22000	- 14	100	221	174	58.5	204	291	202	289	201	287
23000	- 16	100	220	172	58.0	203	295	201	292	200	290
24000	- 17	100	218	172	57.7	202	298	200	296	198	293
25000	- 19	97	211	166	55.9	199	299	197	296	195	294
26000	- 21	94	204	161	54.0	196	299	193	296	192	293
27000	- 23	90	197	155	52.0	192	298	189	294	188	292
28000	- 25	87	190	149	50.1	188	297	185	293	183	290
29000	- 27	83	182	143	48.2	183	296	181	292	178	287
30000	- 29	80	176	138	46.4	179	294	177	290	173	284
31000	- 31	76	168	132	44.5	175	293	172	288	169	282

Figure 5.10.6 - CRUISE PERFORMANCE -
Maximum cruise / ISA + 5°C

(*) Propeller RPM utilization between 1600 and 2000 RPM is possible without changing performance. Display the TRQ indicated in table with Np = 2000 RPM, then reduce Np without resetting power lever (within limits permitted by torque limiter).

CRUISE PERFORMANCE

Maximum cruise

Conditions : **ISA + 10°C**
Landing gear and flaps UP
2000 RPM (*) - BLEED ON

NOTE :
Use preferably recommended cruise power

Pressure altitude (feet)	IOAT (°C)	TRQ (%)	Fuel flow			AIRSPEEDS (kt)					
						4850 lbs (2200 kg)		5512 lbs (2500 kg)		6173 lbs (2800 kg)	
			l / h	kg / h	us gal / h	IAS	TAS	IAS	TAS	IAS	TAS
0	+ 32	100	315	247	83.2	226	233	225	233	224	231
5000	+ 23	100	285	224	75.4	221	245	220	244	219	242
10000	+ 13	100	259	203	68.4	216	258	214	256	213	255
15000	+ 4	100	240	188	63.3	211	272	209	270	208	268
18000	- 1	100	231	181	60.9	208	281	206	278	204	277
20000	- 5	100	226	177	59.7	206	287	203	284	202	283
21000	- 7	100	224	176	59.2	205	291	202	287	201	286
22000	- 9	100	223	175	58.9	203	294	201	291	200	289
23000	- 11	98	218	171	57.6	201	295	200	294	197	290
24000	- 13	96	211	166	55.7	198	296	196	293	194	290
25000	- 15	92	204	160	53.9	195	296	192	292	191	290
26000	- 17	89	197	155	52.0	191	296	188	291	186	288
27000	- 19	86	190	150	50.3	187	295	185	290	182	287
28000	- 20	82	184	144	48.5	184	294	181	289	178	285
29000	- 22	79	176	139	46.6	179	292	176	287	173	282
30000	- 24	75	170	133	44.9	175	290	172	285	168	279
31000	- 26	72	163	128	43.0	171	288	167	283	163	276

Figure 5.10.7 - CRUISE PERFORMANCE -
Maximum cruise / ISA + 10°C

(*) Propeller RPM utilization between 1600 and 2000 RPM is possible without changing performance. Display the TRQ indicated in table with Np = 2000 RPM, then reduce Np without resetting power lever (within limits permitted by torque limiter).

CRUISE PERFORMANCE

Maximum cruise

Conditions : **ISA + 20°C**
Landing gear and flaps UP
2000 RPM (*) - BLEED ON

NOTE :
Use preferably recommended cruise power

Pressure altitude (feet)	IOAT (°C)	TRQ (%)	Fuel flow			AIRSPEEDS (kt)					
						4850 lbs (2200 kg)		5512 lbs (2500 kg)		6173 lbs (2800 kg)	
			l / h	kg / h	us gal / h	IAS	TAS	IAS	TAS	IAS	TAS
0	+ 42	100	319	250	84.3	225	236	224	235	223	233
5000	+ 33	100	289	227	76.3	220	248	218	246	217	245
10000	+ 23	100	262	206	69.3	214	261	213	259	211	257
15000	+ 14	100	243	190	64.1	209	275	207	273	206	270
18000	+ 9	100	234	183	61.7	206	284	204	281	202	279
20000	+ 4	97	225	177	59.4	202	288	201	287	199	284
21000	+ 2	94	218	171	57.5	198	288	198	286	196	283
22000	0	92	211	166	55.7	196	288	193	285	191	282
23000	- 2	88	204	160	53.9	195	292	190	284	188	281
24000	- 3	86	197	155	52.0	188	287	185	283	184	280
25000	- 5	82	190	149	50.2	185	286	182	282	179	278
26000	- 7	79	183	144	48.3	181	285	178	281	175	276
27000	- 9	76	176	139	46.6	176	283	174	279	170	274
28000	- 11	72	170	133	44.8	172	281	169	276	166	272
29000	- 13	69	163	128	43.1	168	280	164	274	161	268
30000	- 15	66	156	122	41.2	164	278	160	272	156	265
31000	- 17	62	150	117	39.5	159	275	155	268	150	260

**Figure 5.10.8 - CRUISE PERFORMANCE -
Maximum cruise / ISA + 20°C**

(*) Propeller RPM utilization between 1600 and 2000 RPM is possible without changing performance. Display the TRQ indicated in table with Np = 2000 RPM, then reduce Np without resetting power lever (within limits permitted by torque limiter).

CRUISE PERFORMANCE

Normal (recommended) cruise

Conditions : **ISA - 20°C**
Landing gear and flaps UP
2000 RPM (*) - BLEED ON

NOTE :

Power recommended by PRATT & WHITNEY CANADA

Pressure altitude (feet)	IOAT (°C)	TRQ (%)	Fuel flow			AIRSPEEDS (kt)					
						4850 lbs (2200 kg)		5512 lbs (2500 kg)		6173 lbs (2800 kg)	
			l / h	kg / h	us gal / h	IAS	TAS	IAS	TAS	IAS	TAS
0	+ 2	100	304	239	80.3	231	226	230	225	229	224
5000	- 8	100	275	216	72.6	226	237	225	236	223	235
10000	- 17	100	250	196	66.0	221	249	220	248	218	246
15000	- 26	100	232	182	61.2	216	263	214	261	213	259
18000	- 32	100	223	175	58.9	213	271	211	269	210	267
20000	- 36	100	218	171	57.6	211	277	209	275	208	273
21000	- 37	100	216	170	57.1	210	280	208	278	207	276
22000	- 39	100	214	168	56.5	209	283	207	281	206	279
23000	- 41	100	212	166	56.0	208	286	206	284	205	282
24000	- 43	100	210	165	55.6	207	290	205	287	203	285
25000	- 45	100	209	164	55.3	206	293	204	291	202	288
26000	- 46	100	208	163	54.9	205	296	203	294	201	291
27000	- 48	100	207	162	54.7	204	300	202	297	200	294
28000	- 50	100	206	162	54.4	203	303	201	301	199	298
29000	- 52	100	206	161	54.3	202	307	200	304	198	301
30000	- 54	100	205	161	54.2	201	310	199	308	197	305
31000	- 56	95	198	155	52.2	197	310	195	306	193	303

Figure 5.10.9 - CRUISE PERFORMANCE -
Normal cruise / ISA - 20°C

(*) Propeller RPM utilization between 1600 and 2000 RPM is possible without changing performance. Display the TRQ indicated in table with Np = 2000 RPM, then reduce Np without resetting power lever (within limits permitted by torque limiter).

CRUISE PERFORMANCE

Normal (recommended) cruise

Conditions : **ISA - 10°C**
Landing gear and flaps UP
2000 RPM (*) - BLEED ON

NOTE :

Power recommended by PRATT & WHITNEY CANADA

Pressure altitude (feet)	IOAT (°C)	TRQ (%)	Fuel flow			AIRSPEEDS (kt)					
						4850 lbs (2200 kg)		5512 lbs (2500 kg)		6173 lbs (2800 kg)	
			l / h	kg / h	us gal / h	IAS	TAS	IAS	TAS	IAS	TAS
0	+ 12	100	308	242	81.4	229	228	228	227	227	226
5000	+ 2	100	279	219	73.6	224	240	223	238	222	237
10000	- 7	100	254	199	67.0	219	252	218	251	216	249
15000	- 16	100	234	184	61.9	214	266	213	264	211	262
18000	- 22	100	225	177	59.4	211	274	209	272	208	270
20000	- 25	100	220	173	58.2	209	281	207	278	206	276
21000	- 27	100	218	171	57.6	208	284	206	281	205	279
22000	- 29	100	216	170	57.1	207	287	205	285	204	282
23000	- 31	100	215	168	56.7	206	290	204	288	202	285
24000	- 33	100	213	167	56.3	205	293	203	291	201	288
25000	- 34	100	212	166	55.9	204	297	202	294	200	291
26000	- 36	100	210	165	55.6	203	300	201	298	199	295
27000	- 38	99	207	162	54.7	201	302	199	299	196	296
28000	- 40	96	199	157	52.7	197	302	195	298	192	294
29000	- 42	92	193	151	50.9	193	300	191	297	188	293
30000	- 44	88	185	145	48.9	188	298	186	295	184	291
31000	- 46	85	179	140	47.2	185	298	182	294	179	289

Figure 5.10.10 - CRUISE PERFORMANCE -
Normal cruise / ISA - 10°C

(*) Propeller RPM utilization between 1600 and 2000 RPM is possible without changing performance. Display the TRQ indicated in table with Np = 2000 RPM, then reduce Np without resetting power lever (within limits permitted by torque limiter).

CRUISE PERFORMANCE

Normal (recommended) cruise

Conditions : **ISA - 5°C**
Landing gear and flaps UP
2000 RPM (*) - BLEED ON

NOTE :

Power recommended by PRATT & WHITNEY CANADA

Pressure altitude (feet)	IOAT (°C)	TRQ (%)	Fuel flow			AIRSPEEDS (kt)					
						4850 lbs (2200 kg)		5512 lbs (2500 kg)		6173 lbs (2800 kg)	
			l / h	kg / h	^{us} gal / h	IAS	TAS	IAS	TAS	IAS	TAS
0	+ 17	100	310	243	81.8	228	230	227	229	226	228
5000	+ 8	100	280	220	74.1	223	241	222	240	221	238
10000	- 2	100	255	200	67.4	218	254	217	252	216	250
15000	- 11	100	235	185	62.2	213	267	212	265	210	263
18000	- 17	100	226	178	59.8	210	276	208	274	207	272
20000	- 20	100	222	174	58.6	208	282	206	280	205	278
21000	- 22	100	220	173	58.1	207	285	205	283	204	281
22000	- 24	100	218	171	57.5	206	289	204	286	203	284
23000	- 26	100	216	170	57.1	205	292	203	289	202	287
24000	- 28	100	215	168	56.7	204	295	202	293	200	290
25000	- 29	100	213	167	56.3	203	298	201	296	199	293
26000	- 31	98	208	163	54.9	200	299	198	295	196	293
27000	- 33	95	201	158	53.1	196	298	194	296	192	292
28000	- 35	91	195	153	51.4	193	298	190	295	187	290
29000	- 37	87	188	147	49.6	188	297	186	293	183	288
30000	- 39	83	181	142	47.7	184	295	182	291	179	287
31000	- 41	80	172	135	45.4	180	293	177	289	174	284

Figure 5.10.11 - CRUISE PERFORMANCE -
Normal cruise / ISA - 5°C

(*) Propeller RPM utilization between 1600 and 2000 RPM is possible without changing performance. Display the TRQ indicated in table with Np = 2000 RPM, then reduce Np without resetting power lever (within limits permitted by torque limiter).

CRUISE PERFORMANCE

Normal (recommended) cruise

Conditions : **ISA**
Landing gear and flaps UP
2000 RPM (*) - BLEED ON

NOTE :

Power recommended by PRATT & WHITNEY CANADA

Pressure altitude (feet)	IOAT (°C)	TRQ (%)	Fuel flow			AIRSPEEDS (kt)					
						4850 lbs (2200 kg)		5512 lbs (2500 kg)		6173 lbs (2800 kg)	
			l / h	kg / h	us gal / h	IAS	TAS	IAS	TAS	IAS	TAS
0	+ 22	100	312	245	82.3	228	231	227	230	226	229
5000	+ 13	100	282	221	74.5	223	243	221	241	220	240
10000	+ 3	100	257	201	67.8	217	255	216	253	215	252
15000	- 6	100	237	186	62.5	212	269	211	267	209	265
18000	- 12	100	228	179	60.2	209	278	208	275	206	273
20000	- 15	100	223	175	58.9	207	284	205	281	204	279
21000	- 17	100	221	174	58.5	206	287	204	285	203	282
22000	- 19	100	220	172	58.0	205	290	203	288	202	285
23000	- 21	100	218	171	57.5	204	293	202	291	201	289
24000	- 22	100	216	170	57.1	203	297	201	294	199	292
25000	- 24	97	209	164	55.3	199	296	197	294	195	291
26000	- 26	94	203	159	53.6	195	295	194	293	191	290
27000	- 28	90	196	154	51.9	192	295	190	292	187	287
28000	- 31	86	190	149	50.1	188	294	186	291	183	286
29000	- 33	83	183	144	48.3	184	293	182	289	178	284
30000	- 35	78	176	138	46.5	180	291	177	287	174	282
31000	- 37	76	166	130	43.9	176	290	173	285	169	279

Figure 5.10.12 - CRUISE PERFORMANCE -
Normal cruise / ISA

(*) Propeller RPM utilization between 1600 and 2000 RPM is possible without changing performance. Display the TRQ indicated in table with Np = 2000 RPM, then reduce Np without resetting power lever (within limits permitted by torque limiter).

CRUISE PERFORMANCE

Normal (recommended) cruise

Conditions : **ISA + 5°C**
Landing gear and flaps UP
2000 RPM (*) - BLEED ON

NOTE :

Power recommended by PRATT & WHITNEY CANADA

Pressure altitude (feet)	IOAT (°C)	TRQ (%)	Fuel flow			AIRSPEEDS (kt)					
						4850 lbs (2200 kg)		5512 lbs (2500 kg)		6173 lbs (2800 kg)	
			l / h	kg / h	us gal / h	IAS	TAS	IAS	TAS	IAS	TAS
0	+ 27	100	313	246	82.8	227	232	226	231	225	230
5000	+ 18	100	283	223	74.9	222	244	221	243	219	241
10000	+ 8	100	258	202	68.1	217	256	215	255	214	253
15000	- 1	100	238	187	62.9	211	270	210	268	208	267
18000	- 6	100	229	180	60.6	208	279	207	277	205	275
20000	- 10	100	224	176	59.3	206	286	204	283	203	281
21000	- 12	100	223	175	58.9	205	288	203	286	202	284
22000	- 14	100	221	174	58.5	204	291	202	289	201	287
23000	- 16	97	216	170	57.1	201	292	199	290	198	287
24000	- 18	95	209	164	55.1	198	292	196	290	194	287
25000	- 20	92	202	159	53.4	194	292	192	289	190	286
26000	- 22	89	195	153	51.5	190	291	189	289	186	285
27000	- 24	84	188	148	49.8	187	290	185	287	181	283
28000	- 26	81	182	143	48.0	183	290	180	286	177	281
29000	- 28	78	175	137	46.2	179	288	176	284	172	278
30000	- 30	74	171	134	45.2	174	286	171	281	168	276
31000	- 32	71	161	126	42.5	171	285	168	280	164	274

Figure 5.10.13 - CRUISE PERFORMANCE -
Normal cruise / ISA + 5°C

(*) Propeller RPM utilization between 1600 and 2000 RPM is possible without changing performance. Display the TRQ indicated in table with Np = 2000 RPM, then reduce Np without resetting power lever (within limits permitted by torque limiter).

CRUISE PERFORMANCE

Normal (recommended) cruise

Conditions : **ISA + 10°C**
Landing gear and flaps UP
2000 RPM (*) - BLEED ON

NOTE :

Power recommended by PRATT & WHITNEY CANADA

Pressure altitude (feet)	IOAT (°C)	TRQ (%)	Fuel flow			AIRSPEEDS (kt)					
						4850 lbs (2200 kg)		5512 lbs (2500 kg)		6173 lbs (2800 kg)	
			l / h	kg / h	us gal / h	IAS	TAS	IAS	TAS	IAS	TAS
0	+ 32	100	315	247	83.2	226	233	225	233	224	231
5000	+ 23	100	285	224	75.4	221	245	220	244	219	242
10000	+ 13	100	259	203	68.4	216	258	214	256	213	255
15000	+ 4	100	240	188	63.3	211	272	209	270	208	268
18000	- 1	100	231	181	60.9	208	281	206	278	204	277
20000	- 6	100	226	177	59.7	206	287	203	284	202	283
21000	- 8	98	220	173	58.1	203	288	202	286	199	283
22000	- 10	96	214	168	56.5	200	289	198	286	196	284
23000	- 12	92	207	162	54.7	197	289	195	286	192	283
24000	- 13	90	200	157	52.8	193	289	191	286	188	282
25000	- 15	87	193	152	51.1	190	288	187	285	185	281
26000	- 17	83	187	147	49.4	185	287	184	284	181	279
27000	- 19	79	181	142	47.7	182	286	179	282	176	277
28000	- 21	76	174	137	46.0	178	285	175	280	172	275
29000	- 23	73	167	131	44.1	173	283	170	278	167	272
30000	- 25	69	166	130	43.9	169	280	166	276	162	269
31000	- 27	67	154	121	40.7	165	279	162	273	157	266

Figure 5.10.14 - CRUISE PERFORMANCE -
Normal cruise / ISA + 10°C

(*) Propeller RPM utilization between 1600 and 2000 RPM is possible without changing performance. Display the TRQ indicated in table with Np = 2000 RPM, then reduce Np without resetting power lever (within limits permitted by torque limiter).

CRUISE PERFORMANCE

Normal (recommended) cruise

Conditions : **ISA + 20°C**
Landing gear and flaps UP
2000 RPM (*) - BLEED ON

NOTE :

Power recommended by PRATT & WHITNEY CANADA

Pressure altitude (feet)	IOAT (°C)	TRQ (%)	Fuel flow			AIRSPEEDS (kt)					
						4850 lbs (2200 kg)		5512 lbs (2500 kg)		6173 lbs (2800 kg)	
			l / h	kg / h	us gal / h	IAS	TAS	IAS	TAS	IAS	TAS
0	+ 42	100	319	250	84.3	225	236	224	235	223	233
5000	+ 33	100	289	227	76.3	219	248	218	246	217	245
10000	+ 23	100	262	206	69.3	214	261	213	259	211	257
15000	+ 14	100	243	190	64.1	209	275	207	273	206	270
18000	+ 9	96	226	177	59.7	202	279	201	278	199	275
20000	+ 4	90	213	167	56.3	196	280	194	277	193	275
21000	+ 2	87	206	162	54.4	193	279	191	277	189	274
22000	0	84	200	157	52.8	189	279	187	276	185	274
23000	- 2	81	193	152	51.0	185	278	184	275	182	272
24000	- 4	78	187	146	49.3	181	276	180	274	178	271
25000	- 6	76	180	141	47.6	177	275	176	273	173	269
26000	- 8	72	173	136	45.8	173	273	172	271	169	267
27000	- 10	69	167	131	44.1	169	272	168	270	164	264
28000	- 12	66	160	126	42.3	164	269	163	268	159	261
29000	- 14	63	157	120	40.6	160	268	159	265	154	257
30000	- 16	60	147	115	38.8	156	265	154	262	149	254
31000	- 18	58	141	111	37.3	153	265	148	257	/	/

Figure 5.10.15 - CRUISE PERFORMANCE -
Normal cruise / ISA + 20°C

(*) Propeller RPM utilization between 1600 and 2000 RPM is possible without changing performance. Display the TRQ indicated in table with Np = 2000 RPM, then reduce Np without resetting power lever (within limits permitted by torque limiter).

CRUISE PERFORMANCE

Intermediate cruise

Conditions : **ISA - 20°C**
Landing gear and flaps UP
2000 RPM (*) - BLEED ON

Pressure altitude (feet)	IOAT (°C)	TRQ (%)	Fuel flow			AIRSPEEDS (kt)					
						4850 lbs (2200 kg)		5512 lbs (2500 kg)		6173 lbs (2800 kg)	
			l / h	kg / h	us gal / h	IAS	TAS	IAS	TAS	IAS	TAS
0	+ 1	88	286	225	75.6	220	215	219	214	218	213
5000	- 8	88	257	202	68.0	215	226	213	222	212	221
10000	- 18	88	233	183	61.6	210	238	209	236	208	234
15000	- 27	88	214	168	56.5	206	250	204	248	202	246
18000	- 32	88	205	161	54.2	203	258	201	256	199	254
20000	- 36	88	200	157	52.8	201	264	199	262	197	259
21000	- 38	88	198	155	52.2	200	267	198	265	196	262
22000	- 40	88	195	153	51.6	199	270	197	268	195	265
23000	- 42	88	193	152	51.1	198	273	196	271	194	268
24000	- 44	88	192	151	50.7	197	276	195	274	193	271
25000	- 45	88	190	149	50.2	196	279	194	277	192	274
26000	- 47	88	188	148	49.7	195	283	193	280	191	277
27000	- 49	88	187	147	49.4	194	286	192	283	190	280
28000	- 51	88	186	146	49.1	193	289	191	286	189	283
29000	- 53	88	185	145	48.9	192	293	190	290	188	286
30000	- 54	87	183	144	48.3	190	294	188	292	185	287
31000	- 56	84.5	178	139	46.9	187	294	185	291	182	287

Figure 5.10.16 - CRUISE PERFORMANCE -
Intermediate cruise / ISA - 20°C

(*) Propeller RPM utilization between 1600 and 2000 RPM is possible without changing performance. Display the TRQ indicated in table with Np = 2000 RPM, then reduce Np without resetting power lever (within limits permitted by torque limiter).

CRUISE PERFORMANCE

Intermediate cruise

Conditions : **ISA - 10°C**
Landing gear and flaps UP
2000 RPM (*) - BLEED ON

Pressure altitude (feet)	IOAT (°C)	TRQ (%)	Fuel flow			AIRSPEEDS (kt)					
						4850 lbs (2200 kg)		5512 lbs (2500 kg)		6173 lbs (2800 kg)	
			l / h	kg / h	us gal / h	IAS	TAS	IAS	TAS	IAS	TAS
0	+ 11	88	289	227	76.3	219	218	218	217	217	216
5000	+ 2	88	261	205	68.9	214	229	212	226	210	224
10000	- 7	88	236	185	62.3	209	241	208	239	206	237
15000	- 17	88	217	170	57.2	204	254	203	252	201	250
18000	- 22	88	207	162	54.7	201	262	200	260	198	257
20000	- 26	88	202	159	53.4	199	268	198	265	196	263
21000	- 28	88	199	157	52.7	198	271	196	268	195	266
22000	- 30	88	198	155	52.2	197	274	196	271	193	268
23000	- 31	88	195	153	51.6	196	277	195	274	192	271
24000	- 33	88	194	152	51.2	195	280	193	277	191	274
25000	- 35	88	192	151	50.7	194	283	192	280	190	277
26000	- 37	88	190	150	50.3	192	285	191	283	188	279
27000	- 39	85	185	146	49.0	189	285	188	283	185	279
28000	- 41	82	179	141	47.3	186	285	184	281	182	278
29000	- 43	79	173	135	45.6	183	285	180	280	177	276
30000	- 45	76	166	130	43.9	179	283	176	279	173	274
31000	- 47	74	162	127	42.7	175	283	173	279	169	274

Figure 5.10.17 - CRUISE PERFORMANCE -
Intermediate cruise / ISA - 10°C

(*) Propeller RPM utilization between 1600 and 2000 RPM is possible without changing performance. Display the TRQ indicated in table with Np = 2000 RPM, then reduce Np without resetting power lever (within limits permitted by torque limiter).

CRUISE PERFORMANCE

Intermediate cruise

Conditions : **ISA - 5°C**
Landing gear and flaps UP
2000 RPM (*) - BLEED ON

Pressure altitude (feet)	IOAT (°C)	TRQ (%)	Fuel flow			AIRSPEEDS (kt)					
						4850 lbs (2200 kg)		5512 lbs (2500 kg)		6173 lbs (2800 kg)	
			l / h	kg / h	^{us} gal / h	IAS	TAS	IAS	TAS	IAS	TAS
0	+ 17	88	290	228	76.7	218	219	217	218	216	217
5000	+ 7	88	262	206	69.3	213	230	211	227	210	225
10000	- 2	88	237	186	62.7	208	242	207	241	205	239
15000	- 12	88	218	171	57.5	203	255	202	253	200	251
18000	- 17	88	209	164	55.1	200	263	199	261	197	259
20000	- 21	88	203	160	53.7	198	269	197	267	195	264
21000	- 23	88	201	158	53.1	197	272	196	270	194	267
22000	- 25	88	199	156	52.5	196	275	195	273	193	270
23000	- 26	88	197	155	52.0	195	278	194	276	191	273
24000	- 28	88	195	153	51.5	194	281	193	279	190	276
25000	- 30	87.5	193	151	50.9	192	283	191	281	188	278
26000	- 32	84.7	187	146	49.3	189	283	187	281	185	277
27000	- 34	82	181	142	47.7	185	283	184	280	181	276
28000	- 36	79	174	137	46.0	182	282	180	279	177	274
29000	- 38	76	167	131	44.2	178	281	175	277	172	272
30000	- 40	73.3	161	126	42.5	174	280	171	275	168	270
31000	- 42	69.5	156	122	41.1	170	278	167	273	163	267

Figure 5.10.18 - CRUISE PERFORMANCE -
Intermediate cruise / ISA - 5°C

(*) Propeller RPM utilization between 1600 and 2000 RPM is possible without changing performance. Display the TRQ indicated in table with Np = 2000 RPM, then reduce Np without resetting power lever (within limits permitted by torque limiter).

CRUISE PERFORMANCE

Intermediate cruise

Conditions : **ISA**
Landing gear and flaps UP
2000 RPM (*) - BLEED ON

Pressure altitude (feet)	IOAT (°C)	TRQ (%)	Fuel flow			AIRSPEEDS (kt)					
						4850 lbs (2200 kg)		5512 lbs (2500 kg)		6173 lbs (2800 kg)	
			l / h	kg / h	us gal / h	IAS	TAS	IAS	TAS	IAS	TAS
0	+ 22	88	292	229	77.1	218	221	216	219	215	218
5000	+ 12	88	264	207	69.8	213	232	210	228	209	227
10000	+ 3	88	239	188	63.1	208	243	206	242	205	240
15000	- 7	88	219	172	57.9	203	257	201	255	199	253
18000	- 12	88	210	165	55.5	199	265	198	263	196	260
20000	- 16	88	204	161	54.0	197	271	196	269	194	266
21000	- 18	88	202	159	53.5	196	273	195	272	193	269
22000	- 20	88	200	157	52.8	195	277	194	275	192	272
23000	- 21	88	198	156	52.4	194	280	193	278	191	275
24000	- 23	87.3	195	153	51.5	193	283	191	280	188	276
25000	- 25	84.3	188	148	49.8	189	282	188	279	185	275
26000	- 27	81.2	182	143	48.1	185	281	184	278	181	274
27000	- 29	78	176	138	46.4	182	280	180	277	177	272
28000	- 31	75	169	133	44.6	178	279	176	276	172	270
29000	- 33	72	162	128	42.9	174	277	171	273	168	268
30000	- 35	69	156	122	41.2	170	276	167	271	163	265
31000	- 37	66	151	118	39.8	165	273	162	268	158	262

Figure 5.10.19 - CRUISE PERFORMANCE -
Intermediate cruise / ISA

(*) Propeller RPM utilization between 1600 and 2000 RPM is possible without changing performance. Display the TRQ indicated in table with Np = 2000 RPM, then reduce Np without resetting power lever (within limits permitted by torque limiter).

CRUISE PERFORMANCE

Intermediate cruise

Conditions : **ISA + 5°C**
Landing gear and flaps UP
2000 RPM (*) - BLEED ON

Pressure altitude (feet)	IOAT (°C)	TRQ (%)	Fuel flow			AIRSPEEDS (kt)					
						4850 lbs (2200 kg)		5512 lbs (2500 kg)		6173 lbs (2800 kg)	
			l / h	kg / h	us gal / h	IAS	TAS	IAS	TAS	IAS	TAS
0	+ 27	88	293	230	77.5	217	222	216	221	215	220
5000	+ 17	88	266	209	70.2	212	233	209	229	208	228
10000	+ 8	88	240	188	63.4	207	245	205	243	204	242
15000	- 2	88	220	173	58.2	202	258	200	256	199	254
18000	- 7	88	211	166	55.8	199	266	197	264	195	262
20000	- 11	88	206	162	54.4	196	272	195	270	193	268
21000	- 13	88	204	160	53.9	195	275	194	273	192	270
22000	- 14	88	201	158	53.1	194	278	193	276	190	272
23000	- 16	85.6	195	153	51.5	191	279	189	276	187	272
24000	- 18	82.7	189	148	49.9	188	279	186	276	183	272
25000	- 20	79.8	182	143	48.2	185	278	182	275	180	271
26000	- 22	76.9	176	139	46.6	181	277	179	274	175	269
27000	- 24	74	170	134	45.0	177	275	174	272	172	269
28000	- 27	71	164	129	43.3	173	274	170	270	166	264
29000	- 29	68.1	157	124	41.6	169	273	166	268	162	262
30000	- 31	65.2	151	119	39.9	165	271	161	266	158	260
31000	- 33	62.5	146	114	38.5	160	269	157	263	152	256

Figure 5.10.20 - CRUISE PERFORMANCE -
Intermediate cruise / ISA + 5°C

(*) Propeller RPM utilization between 1600 and 2000 RPM is possible without changing performance. Display the TRQ indicated in table with Np = 2000 RPM, then reduce Np without resetting power lever (within limits permitted by torque limiter).

CRUISE PERFORMANCE

Intermediate cruise

Conditions : **ISA + 10°C**
Landing gear and flaps UP
2000 RPM (*) - BLEED ON

Pressure altitude (feet)	IOAT (°C)	TRQ (%)	Fuel flow		AIRSPEEDS (kt)						
					4850 lbs (2200 kg)		5512 lbs (2500 kg)		6173 lbs (2800 kg)		
			l/h	kg/h	us gal/h	IAS	TAS	IAS	TAS	IAS	TAS
0	+ 32	88	295	232	77.9	216	223	215	222	214	221
5000	+ 22	88	267	210	70.6	211	234	209	230	208	229
10000	+ 13	88	241	189	63.7	206	246	205	245	203	243
15000	+ 4	88	221	174	58.5	201	259	199	258	198	255
18000	- 2	88	212	167	56.1	198	268	196	266	194	263
20000	- 6	88	207	162	54.6	196	274	194	272	192	269
21000	- 8	86.5	201	158	53.1	194	275	191	272	189	269
22000	- 10	84	195	153	51.5	190	275	188	272	186	269
23000	- 12	81	190	149	50.1	187	275	185	271	182	268
24000	- 14	78	183	144	48.3	184	275	181	271	178	267
25000	- 16	75.5	177	139	46.8	180	273	177	270	174	266
26000	- 18	73	171	134	45.2	176	272	174	269	170	263
27000	- 20	70	165	130	43.6	172	271	169	267	168	265
28000	- 22	67	159	124	41.9	168	269	165	265	161	258
29000	- 24	64	153	120	40.3	164	268	160	262	157	256
30000	- 26	61	146	115	38.6	160	266	156	260	153	255
31000	- 28	59	141	111	37.3	155	264	152	257	/	/

Figure 5.10.21 - CRUISE PERFORMANCE -
Intermediate cruise / ISA + 10°C

(*) Propeller RPM utilization between 1600 and 2000 RPM is possible without changing performance. Display the TRQ indicated in table with Np = 2000 RPM, then reduce Np without resetting power lever (within limits permitted by torque limiter).

CRUISE PERFORMANCE

Intermediate cruise

Conditions : **ISA + 20°C**
Landing gear and flaps UP
2000 RPM (*) - BLEED ON

Pressure altitude (feet)	IOAT (°C)	TRQ (%)	Fuel flow			AIRSPEEDS (kt)					
						4850 lbs (2200 kg)		5512 lbs (2500 kg)		6173 lbs (2800 kg)	
			l / h	kg / h	us gal / h	IAS	TAS	IAS	TAS	IAS	TAS
0	+ 42	88	299	235	79.0	215	225	214	224	213	223
5000	+ 32	88	271	212	71.5	210	237	208	233	206	232
10000	+ 23	88	245	192	64.6	205	249	203	247	202	245
15000	+ 14	88	224	176	59.3	199	262	198	260	196	258
18000	+ 8	84	209	164	55.2	192	266	190	263	189	261
20000	+ 4	79	196	154	51.9	186	266	185	263	182	260
21000	+ 2	76.4	190	150	50.3	183	266	181	263	179	259
22000	0	74	184	144	48.6	180	265	178	262	175	258
23000	- 2	71.2	178	140	47.0	176	264	174	262	171	257
24000	- 4	69	172	135	45.4	173	264	171	261	167	255
25000	- 6	66	165	130	43.7	169	262	166	259	162	253
26000	- 8	63.4	159	125	42.1	165	261	162	256	158	250
27000	- 10	60.7	154	120	40.6	160	258	157	254	153	247
28000	- 12	58	148	116	39.0	157	257	153	251	148	243
29000	- 14	55.5	141	111	37.2	152	254	148	248	142	238
30000	- 17	53	135	106	35.7	148	252	143	244	136	232
31000	- 19	51	130	102	34.3	143	249	/	/	/	/

Figure 5.10.22 - CRUISE PERFORMANCE -
Intermediate cruise / ISA + 20°C

(*) Propeller RPM utilization between 1600 and 2000 RPM is possible without changing performance. Display the TRQ indicated in table with Np = 2000 RPM, then reduce Np without resetting power lever (within limits permitted by torque limiter).

CRUISE PERFORMANCE

Long Range Cruise (5512 lbs - 2500 kg)

Conditions : Landing gear and flaps UP
2000 RPM (*) - BLEED ON

LEGEND :	IOAT: °C	IAS : KIAS
	FF : us gal/h	
	FF : lbs/h	TAS: KTAS

Pressure altitude (feet)	TRQ (%)	ISA - 20°C		ISA - 10°C		ISA		ISA + 10°C		ISA + 20°C	
		IOAT	FF	IOAT	FF	IOAT	FF	IOAT	FF	IOAT	FF
15000	60.5	- 28	176	- 18	174	- 8	172	+ 2	171	+ 12	169
		46.4		47.0		47.6		48.2		48.9	
		304	214	309	216	311	219	315	221	320	223
18000	59.0	- 34	171	- 24	169	- 14	168	- 4	166	+ 6	165
		43.2		43.7		44.4		45.0		45.7	
		282	218	287	221	291	223	295	226	300	228
19000	58.5	- 36	169	- 26	167	- 16	166	- 6	164	+ 4	163
		42.2		42.7		43.4		44.1		44.7	
		276	220	280	222	284	225	289	227	293	229
20000	58.0	- 38	168	- 28	166	- 18	164	- 8	163	+ 2	161
		41.2		41.7		42.4		43.1		43.7	
		269	222	273	224	278	226	282	228	287	231
21000	57.5	- 40	166	- 30	164	- 20	163	- 10	161	+ 0	160
		40.4		40.8		41.5		42.1		42.7	
		265	223	267	225	271	228	276	230	280	232
22000	57.0	- 42	165	- 32	163	- 22	161	- 12	159	- 1	158
		39.5		39.9		40.6		41.2		41.7	
		258	224	262	227	265	229	269	232	273	234
23000	56.5	- 44	163	- 34	161	- 24	159	- 13	158	- 3	156
		38.7		39.1		39.7		40.3		40.9	
		254	226	256	228	260	231	265	233	267	235
24000	56.0	- 46	161	- 36	159	- 25	158	- 15	156	- 5	154
		37.9		38.3		38.8		39.4		40.0	
		249	227	251	230	254	232	258	234	262	237

Figure 5.10.23 (1/2) - CRUISE PERFORMANCE -
Long Range Cruise (5512 lbs - 2500 kg) (Altitude ≤ 24000 ft)

(*) Propeller RPM utilization between 1600 and 2000 RPM is possible without changing performance. Display the TRQ indicated in table with Np = 2000 RPM, then reduce Np without resetting power lever (within limits permitted by torque limiter).

CRUISE PERFORMANCE

Long Range Cruise (5512 lbs - 2500 kg) (Cont'd)

Conditions : Landing gear and flaps UP
2000 RPM (*) - BLEED ON

LEGEND : IOAT: °C IAS : KIAS
FF : us gal/h
FF : lbs/h TAS: KTAS

Altitude pression (feet)	TRQ (%)	ISA - 20°C		ISA - 10°C		ISA		ISA + 10°C		ISA + 20°C	
24000	56.0	- 46 37.9 249	161 227	- 36 38.3 251	159 230	- 25 38.8 254	158 232	- 15 39.4 258	156 234	- 5 40.0 262	154 237
25000	55.5	- 48 37.2 243	159 228	- 38 37.6 247	158 231	- 27 38.1 249	156 233	- 17 38.6 254	154 236	- 7 39.2 256	153 238
26000	55.0	- 50 36.5 238	157 229	- 39 36.9 243	156 232	- 29 37.4 245	154 235	- 19 37.8 247	152 237	- 9 38.3 251	151 239
27000	54.5	- 52 35.8 234	156 230	- 41 36.2 238	154 233	- 31 36.7 240	152 236	- 21 37.1 243	151 238	- 11 37.6 247	149 240
28000	54.0	- 53 35.1 229	154 231	- 43 35.5 234	152 235	- 33 36.1 236	151 237	- 23 36.5 238	149 239	- 13 37.0 243	147 241
29000	53.5	- 55 34.6 227	152 232	- 45 35.0 229	150 236	- 35 35.5 231	149 239	- 25 35.9 236	147 241	- 15 36.3 238	145 242
30000	54.0	- 57 34.4 225	152 237	- 47 34.8 228	150 239	- 37 35.2 231	148 242	- 27 35.7 234	146 244	- 17 36.1 236	144 246
31000	54.5	- 59 34.2 224	151 240	- 49 34.7 227	149 243	- 39 35.1 230	147 245	- 29 35.5 233	145 247	- 19 35.9 235	144 249

Figure 5.10.23 (2/2) - CRUISE PERFORMANCE -
Long Range Cruise (5512 lbs - 2500 kg) (Altitude ≥ 24000 ft)

(*) Propeller RPM utilization between 1600 and 2000 RPM is possible without changing performance. Display the TRQ indicated in table with Np = 2000 RPM, then reduce Np without resetting power lever (within limits permitted by torque limiter).

CRUISE PERFORMANCE

Long Range Cruise (6173 lbs - 2800 kg)

Conditions : Landing gear and flaps UP
2000 RPM (*) - BLEED ON

LEGEND :	IOAT: °C	IAS : KIAS
	FF : us gal/h	
	FF : lbs/h	TAS: KTAS

Altitude pression (feet)	TRQ (%)	ISA - 20°C		ISA - 10°C		ISA		ISA + 10°C		ISA + 20°C	
15000	65.5	- 28	179	- 18	177	- 8	176	+ 2	174	+ 12	172
		48.1		48.8		49.5		50.1		50.8	
		315	218	320	220	324	223	328	225	333	227
18000	64.0	- 34	174	- 24	172	- 14	171	- 4	169	+ 6	167
		45.0		45.7		46.2		47.0		47.6	
		295	222	300	225	302	227	309	230	311	232
19000	63.5	- 36	172	- 26	170	- 16	169	- 6	167	+ 4	166
		44.1		44.7		45.3		46.0		46.6	
		289	223	293	226	298	229	302	231	304	233
20000	63.0	- 38	170	- 28	169	- 18	167	- 8	166	+ 3	164
		43.2		43.7		44.4		45.0		45.6	
		282	225	287	227	291	230	295	233	298	234
21000	62.5	- 40	169	- 30	167	- 20	166	- 9	164	+ 1	162
		42.3		42.9		43.5		44.1		44.6	
		278	226	280	229	284	232	289	234	293	236
22000	62.0	- 42	167	- 32	165	- 21	164	- 11	162	- 1	161
		41.5		42.0		42.5		43.2		43.7	
		271	227	276	230	278	233	282	236	287	238
23000	61.5	- 44	165	- 34	164	- 23	162	- 13	161	- 3	159
		40.6		41.1		41.7		42.3		42.9	
		267	229	269	232	273	235	278	237	280	239
24000	61.0	- 46	164	- 35	162	- 25	161	- 15	159	- 5	157
		39.8		40.3		40.8		41.5		42.0	
		260	230	265	233	267	236	271	238	276	240

Figure 5.10.24 (1/2) - CRUISE PERFORMANCE -
Long Range Cruise (6173 lbs - 2800 kg) (Altitude ≤ 24000 ft)

(*) Propeller RPM utilization between 1600 and 2000 RPM is possible without changing performance. Display the TRQ indicated in table with Np = 2000 RPM, then reduce Np without resetting power lever (within limits permitted by torque limiter).

CRUISE PERFORMANCE

Long Range Cruise (6173 lbs - 2800 kg) (Cont'd)

Conditions : Landing gear and flaps UP
2000 RPM (*) - BLEED ON

LEGEND :	IOAT: °C	IAS : KIAS
	FF : us gal/h	
	FF : lbs/h	TAS : KTAS

Altitude pression (feet)	TRQ (%)	ISA - 20°C		ISA - 10°C		ISA		ISA + 10°C		ISA + 20°C	
24000	61.0	- 46	164	- 35	162	- 25	161	- 15	159	- 5	157
		39.8		40.3		40.8		41.5		42.0	
		260	230	265	233	267	236	271	238	276	240
25000	60.5	- 47	162	- 37	160	- 27	159	- 17	157	- 7	155
		39.0		39.6		40.1		40.7		41.2	
		256	232	260	235	262	237	267	239	269	241
26000	60.0	- 49	160	- 39	159	- 29	157	- 19	155	- 9	153
		38.3		38.8		39.4		39.9		40.4	
		251	233	254	236	258	239	262	241	265	243
27000	59.5	- 51	159	- 41	157	- 31	155	- 21	153	- 11	151
		37.6		38.2		38.7		39.2		39.8	
		247	235	249	237	254	240	258	242	260	244
28000	59.0	- 53	157	- 43	155	- 33	153	- 23	151	- 13	149
		37.0		37.5		38.0		38.6		39.1	
		243	236	245	238	249	241	254	243	256	245
29000	58.5	- 55	155	- 45	153	- 35	151	- 25	149	- 15	147
		36.5		37.0		37.5		38.0		38.5	
		238	238	243	239	245	242	249	244	251	246
30000	59.0	- 57	154	- 47	152	- 37	150	- 27	148	- 17	146
		36.4		36.9		37.3		37.8		38.2	
		238	240	242	243	244	245	248	247	250	248
31000	59.5	- 59	154	- 49	152	- 39	149	- 29	147	- 19	145
		36.3		36.7		37.2		37.7		38.1	
		238	244	240	246	244	248	247	250	250	252

Figure 5.10.24 (2/2) - CRUISE PERFORMANCE -
Long Range Cruise (6173 lbs - 2800 kg) (Altitude ≥ 24000 ft)

(*) Propeller RPM utilization between 1600 and 2000 RPM is possible without changing performance. Display the TRQ indicated in table with Np = 2000 RPM, then reduce Np without resetting power lever (within limits permitted by torque limiter).

5.11 - TIME, CONSUMPTION AND DESCENT DISTANCE

Conditions : Power as required to maintain constant Vz
Landing gear and flaps UP
CAS = 230 KCAS - 2000 RPM - BLEED ON

Pressure altitude (feet)	Vz = 1500 ft/min					Vz = 2000 ft/min					Vz = 2500 ft/min				
	Time (min. s)	Consump.			Dist. (NM)	Time (min. s)	Consump.			Dist. (NM)	Time (min. s)	Consump.			Dist. (NM)
		l	kg	us gal			l	kg	us gal			l	kg	us gal	
30000	20.00	70	55	18.5	92	15.00	50	39	13.2	70	12.00	37	29	9.8	57
28000	18.40	67	53	17.7	85	14.00	47	37	12.4	65	11.10	34	27	9	52
26000	17.20	63	49	16.6	80	13.00	43	34	11.4	60	10.25	32	25	8.4	48
24000	16.00	58	45	15.3	72	12.00	41	32	10.8	55	09.35	29	23	7.7	43
22000	14.40	54	42	14.3	65	11.00	37	29	9.8	50	08.50	27	21	7.1	39
20000	13.20	49	39	12.9	58	10.00	34	27	9	45	08.00	24	19	6.3	35
18000	12.00	45	35	11.9	50	09.00	31	24	8.2	40	07.10	23	18	6.1	31
16000	10.40	40	31	10.6	45	08.00	28	22	7.4	35	06.25	20	16	5.3	27
14000	09.20	35	28	9.2	40	07.00	24	19	6.3	30	05.35	18	14	4.8	23
12000	08.00	31	24	8.2	33	06.00	20	16	5.3	25	04.50	15	12	4	20
10000	06.40	26	20	6.9	27	05.00	18	14	4.8	20	04.00	13	10	3.4	16
8000	05.20	21	16	5.5	20	04.00	14	11	3.7	16	03.10	10	8	2.6	13
6000	04.00	16	12	4.2	15	03.00	11	9	2.9	12	02.25	8	6	2.1	10
4000	02.40	10	8	2.6	10	02.00	8	6	2.1	8	01.35	5	4	1.3	6
2000	01.20	5	4	1.3	5	01.00	4	3	1.1	4	00.50	3	2	0.8	3
SL	00.00	0	0	0	0	00.00	0	0	0	0	00.00	0	0	0	0

Figure 5.11.1 - TIME, CONSUMPTION AND DESCENT DISTANCE

INTENTIONALLY LEFT BLANK

5.12 - HOLDING TIME

Conditions : Landing gear and flaps UP
 IAS = 120 KIAS - 2000 RPM - BLEED ON
 TRQ ≈ 30 %

Pressure altitude (feet)	FUEL USED DURING HOLDING TIME											
	Weight 4850 lbs (2200 kg)						Weight 5512 lbs (2500 kg)					
	10 min			30 min			10 min			30 min		
	l	kg	us gal	l	kg	us gal	l	kg	us gal	l	kg	us gal
SL	29	23	7.7	87	69	23.0	31	24	8.2	93	72	24.6
5000	25	20	6.6	75	60	19.8	27	21	7.1	81	63	21.4
10000	23	18	6.1	69	54	18.2	24	19	6.3	72	57	19.0
15000	20	16	5.3	60	48	15.8	22	17	5.8	66	51	17.4
20000	19	15	5.0	57	45	15.0	20	16	5.3	60	48	15.8

Figure 5.12.1 - HOLDING TIME

INTENTIONALLY LEFT BLANK

5.13 - LANDING DISTANCES

(Refer to Supplement 41 for TBM 700C2 airplane)

WEIGHT : 6250 lbs (2835 kg)

- Associated conditions:
- Landing gear DN and flaps LDG
 - Approach speed IAS = 80 KIAS
 - Touch-down speed IAS = 65 KIAS
 - Maximum braking without reverse
 - Hard, dry and level runway
 - GR = Ground roll (in ft)
 - D₅₀ = Landing distance (clear to 50 ft) (in ft)

PRESSURE ALTITUDE ft	ISA - 35°C		ISA - 20°C		ISA - 10°C		ISA	
	GR	D50	GR	D50	GR	D50	GR	D50
0	1050	1900	1115	2000	1180	2070	1215	2135
2000	1115	2000	1215	2100	1245	2200	1310	2265
4000	1180	2100	1280	2230	1345	2330	1410	2395
6000	1280	2230	1380	2360	1445	2460	1510	2525
8000	1380	2360	1475	2490	1540	2590	1610	2690
PRESSURE ALTITUDE ft	ISA + 10°C		ISA + 20°C		ISA + 30°C		ISA + 37°C	
	GR	D50	GR	D50	GR	D50	GR	D50
0	1280	2200	1310	2300	1380	2360	1445	2430
2000	1345	2330	1410	2430	1475	2495	1540	2560
4000	1445	2460	1510	2560	1575	2655	1640	2755
6000	1575	2645	1640	2720	1705	2820	1770	2920
8000	1705	2790	1770	2885	1835	2985	1900	3085

Figure 5.13.1 - LANDING DISTANCES - 6250 lbs (2835 kg)

Corrections :

- . Reduce total distances of 10 % every 10 kt of headwind
- . Increase total distances of 30 % every 10 kt of tail-wind

Other runway surfaces require the following correction factors :

Increase by :

7 %	on hard grass	25 %	on high grass
10 %	on short grass	30 %	on slippery runway
15 %	on wet runway		

LANDING DISTANCES

WEIGHT : 5071 lbs (2300 kg)

- Associated conditions :
- Landing gear DN and flaps LDG
 - Approach speed IAS = 80 KIAS
 - Touch-down speed IAS = 60 KIAS
 - Maximum braking without reverse
 - Hard, dry and level runway
 - GR = Ground roll (in ft)
 - D₅₀ = Landing distance (clear to 50 ft) (in ft)

PRESSURE ALTITUDE ft	ISA - 35°C		ISA - 20°C		ISA - 10°C		ISA	
	GR	D50	GR	D50	GR	D50	GR	D50
0	885	1900	950	2000	1000	2070	1030	2135
2000	950	2000	1030	2100	1065	2200	1115	2265
4000	1000	2100	1080	2230	1150	2330	1200	2395
6000	1080	2230	1180	2360	1230	2460	1280	2525
8000	1180	2360	1245	2490	1310	2590	1360	2690
PRESSURE ALTITUDE ft	ISA + 10°C		ISA + 20°C		ISA + 30°C		ISA + 37°C	
	GR	D50	GR	D50	GR	D50	GR	D50
0	1080	2200	1115	2300	1180	2360	1230	2430
2000	1150	2330	1200	2430	1245	2495	1310	2560
4000	1230	2460	1280	2560	1345	2655	1395	2755
6000	1345	2645	1395	2720	1445	2820	1510	2920
8000	1445	2790	1510	2885	1560	2985	1610	3085

Figure 5.13.2 - LANDING DISTANCES - 5071 lbs (2300 kg)

- Corrections :
- Reduce total distances of 10 % every 10 kt of headwind
 - Increase total distances of 30 % every 10 kt of tail-wind

Other runway surfaces require the following correction factors :

- Increase by :
- | | | | |
|------|----------------|------|--------------------|
| 7 % | on hard grass | 25 % | on high grass |
| 10 % | on short grass | 30 % | on slippery runway |
| 15 % | on wet runway | | |

SECTION 6

WEIGHT AND BALANCE

TABLE OF CONTENTS

	Page
6.1 GENERAL	6.1.1
6.2 AIRPLANE WEIGHING PROCEDURES	6.2.1
6.3 BAGGAGE LOADING	6.3.1
6.4 DETERMINING WEIGHT AND BALANCE	6.4.1
GENERAL	6.4.1
UTILIZATION OF WEIGHT AND BALANCE GRAPH	6.4.1
DETERMINING EMPTY AIRPLANE CHARACTERISTICS	6.4.7
6.5 LIST OF EQUIPMENT	6.5.1

INTENTIONALLY LEFT BLANK

6.1 - GENERAL

This section contains the procedure for determining the basic empty weight and the balance corresponding to the TBM 700 airplane. Procedures for calculating the weight and the balance for various flight operations are also provided. A list of equipment available for this airplane is included at the end of this section.

It should be noted that the list of specific optional equipment installed on your airplane as delivered from the factory can be found in the records carried in the airplane.

IT IS THE PILOT'S RESPONSIBILITY TO ENSURE THAT THE AIRPLANE IS LOADED PROPERLY AND THE WEIGHT AND BALANCE LIMITS ARE ADHERED TO.

INTENTIONALLY LEFT BLANK

6.2 - AIRPLANE WEIGHING PROCEDURES

Refer to Maintenance Manual for the procedures to use.

NOTE :

Weighing carried out at the factory takes into account all equipment installed on the airplane. The list of this equipment and the total weight is noted in the Individual Inspection Record.

INTENTIONALLY LEFT BLANK

6.3 - BAGGAGE LOADING

There are two baggage compartments :

- one located in the rear of the pressurized cabin provides a maximum baggage capacity between 187 lbs (85 kg) and 220 lbs (100 kg),
- the other one located in the rear fuselage section, non pressurized, between the rear pressure bulkhead at frame C17 and the frame C18 provides a maximum baggage capacity between 55 lbs (25 kg) and 77 lbs (35 kg).

Baggage compartment maximum loading, as well as load distribution among the baggage compartments must be determined using the baggage loading graph (Figure 6.3.1).

Stowing straps are provided for securing parcels and baggage on pressurized baggage compartment floor.

A partition net separating the cabin from the baggage compartment is attached to frame C14.

The rear (non pressurized) baggage compartment is provided with a holding elastic net.

WARNING

IT IS THE PILOT'S RESPONSIBILITY TO CHECK THAT ALL THE PARCELS AND BAGGAGES ARE PROPERLY SECURED IN THE CABIN.

TRANSPORT OF DANGEROUS PRODUCT IS NORMALLY PROHIBITED. HOWEVER IF TRANSPORT OF SUCH PRODUCT IS NECESSARY, IT WILL BE PERFORMED IN COMPLIANCE WITH REGULATIONS CONCERNING TRANSPORT OF DANGEROUS PRODUCT AND ANY OTHER APPLICABLE REGULATION

Weight and balance graph should be checked to ensure the airplane is within the allowable limits.

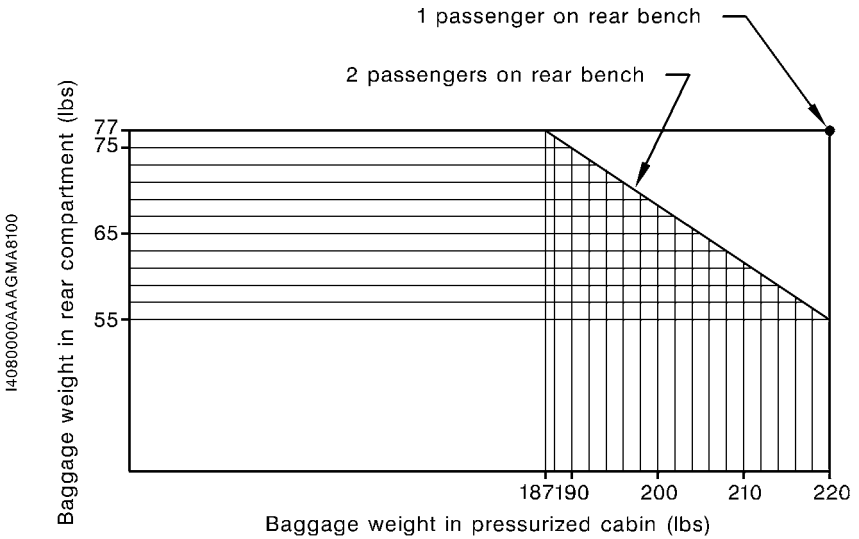
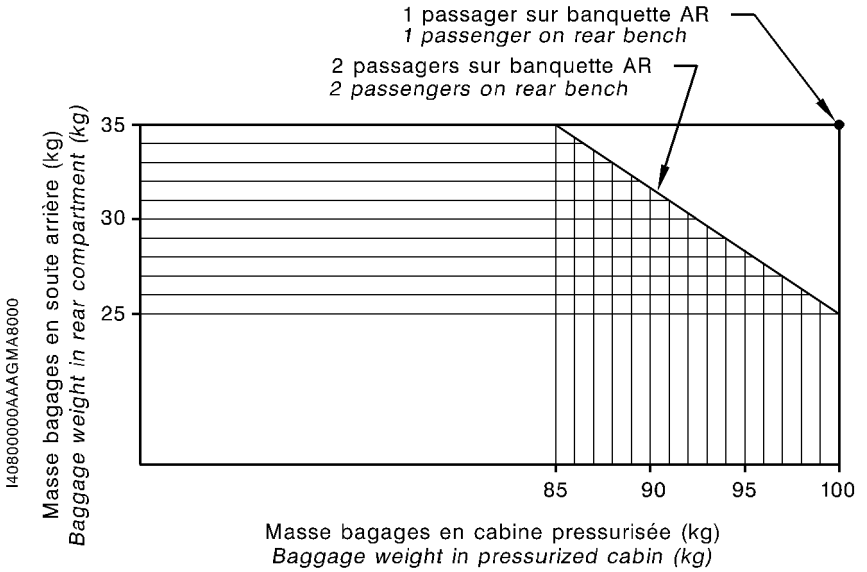

Figure 6.3.1 - BAGGAGE LOADING GRAPH

6.4 - DETERMINING WEIGHT AND BALANCE

GENERAL

This paragraph is intended to provide the pilot with a simple and rapid means of determining weight and balance of his airplane.

IT IS THE PILOT'S RESPONSIBILITY TO ENSURE THAT THE AIRPLANE IS LOADED PROPERLY AND THE WEIGHT AND BALANCE LIMITS ARE ADHERED TO.

Empty weight to be considered is the weight noted on last weighing form. To this empty weight corresponds a basic balance, expressed in percent of mean aerodynamic chord. Empty weight and the corresponding balance allow to calculate the airplane basic index.

If airplane empty weight has varied since last weighing form, refer to paragraph "DETERMINING EMPTY AIRPLANE CHARACTERISTICS" to determine new empty weight and the corresponding balance (for instance : optional equipment installation).

UTILIZATION OF WEIGHT AND BALANCE GRAPH (Figures 6.4.1, 6.4.1A and 6.4.2, 6.4.2A)

■ (Refer to Supplement 41 for TBM 700C2 airplane)

EXAMPLES :

	SAMPLE 1 Fig. 6.4.1	SAMPLE 2 Fig. 6.4.1A
1 - Airplane basic characteristics :		
W = Empty weight	: 1860 kg	4100 lbs
CG = Balance (m.a.c. %)	: 16 %	16 %
2 - Foreseen loading :		
1 Pilot and 1 front Passenger	: 150 kg	400 lbs
2 Intermediate Passengers	: 100 kg	300 lbs
2 Rear Passengers	: 100 kg	200 lbs
Cargo in pressurized cabin	: 60 kg	100 lbs
Fuel	: 500 kg	1000 lbs

3 - Utilization of weight and balance graph :

- Record airplane basic characteristics in ①.
- Compute basic index with the formula described in ② and record the result in ③.
- Record foreseen loading in ④ and compute total weight of the loaded airplane.

NOTE :

Intermediate calculation of total weight without fuel allows, taking into account the "Maximum Weight" limit, computing rapidly fuel quantity liable to be loaded.

A conversion scale (lb / us gal) allows quick computation from fuel pounds to us gallons.

- Note computed index ③ on upper index scale and proceed as follows :
 - a) Vertically mark a line downwards up to interception of oblique lines of first heading "Front seats".
 - b) Then continue the line horizontally following direction given by arrow according to indicated value of loading (400 lbs or 150 kg in example) **(the weight indicated in the arrow gives pitch value between two oblique lines)**.
 - c) Then continue the line vertically downwards up to interception of oblique lines of second heading and work in the same way as before (procedure described in b).
 - d) Proceed in the same way for remaining headings.
- Draw then a vertical line ⑤ corresponding to final index (loaded airplane) up to interception of horizontal line representing airplane total weight ⑥.
- Read corresponding balance (30.2 % in kg and litres or 29.2 % in lbs and us gal in examples) by checking that obtained point is inside the weight and balance envelope.
Check also that the total zero fuel weight does not exceed the max. zero fuel weight of 6001 lbs (2722 kg). If not, reconsider airplane loading.
- Record these data on your navigation log.

①	②	③	
Empty weight (W)	CG (MAC %)	Index calculation	Basic index
1860	16	$I = \frac{(CG - 28) \cdot W}{600} + 80$	42.8

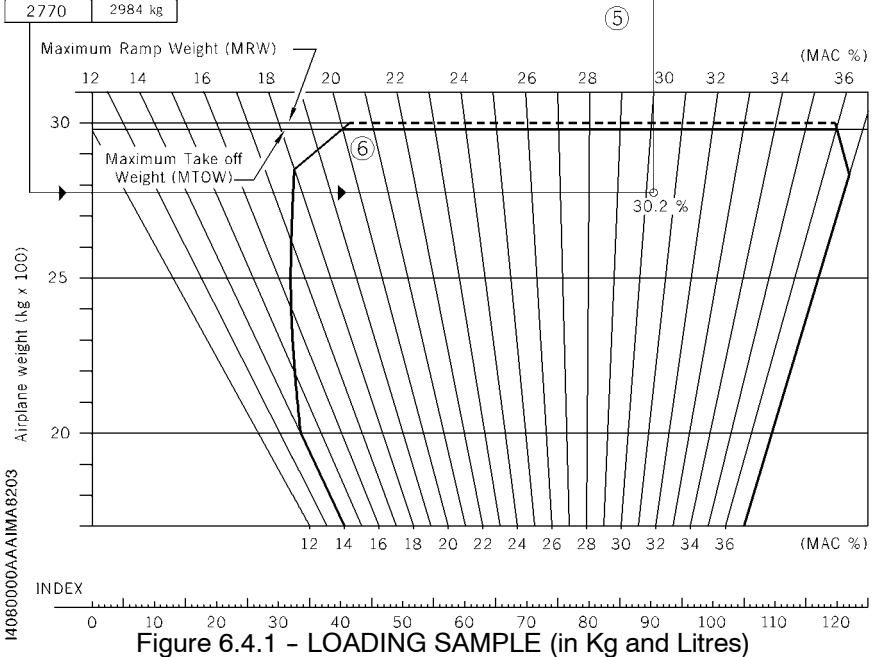
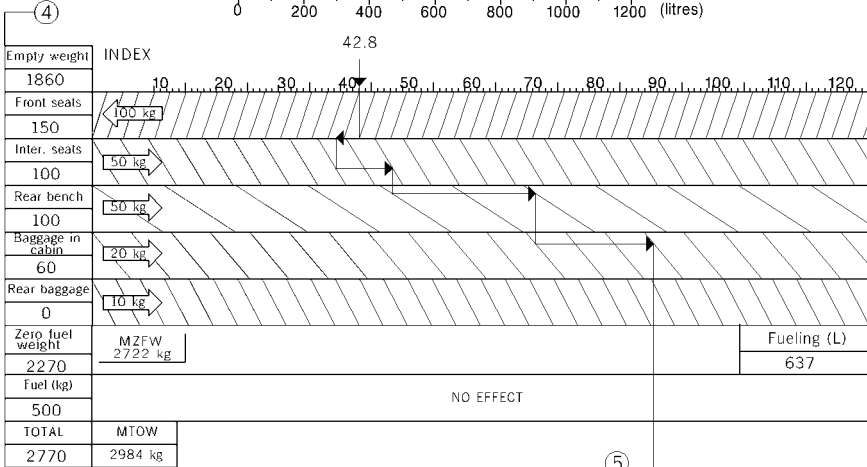
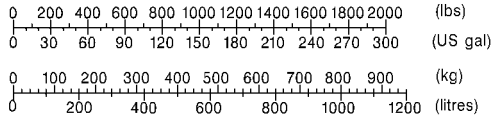
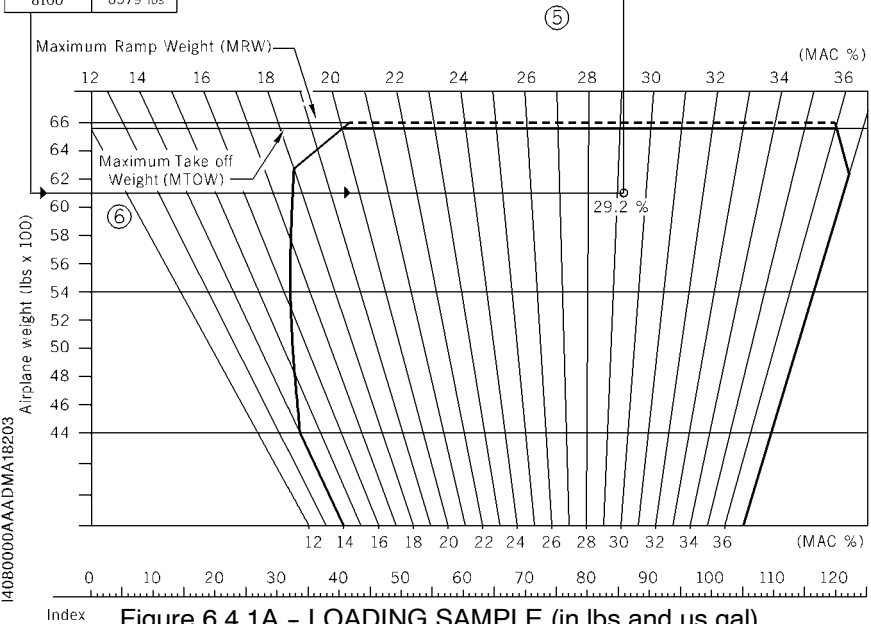
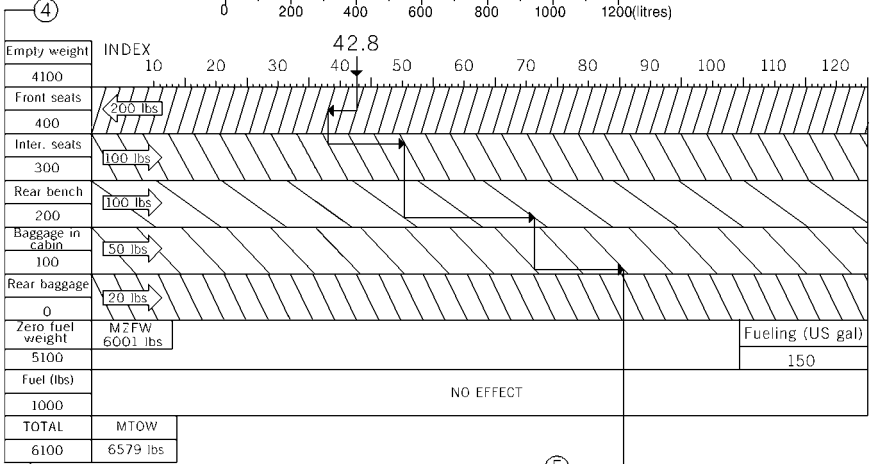
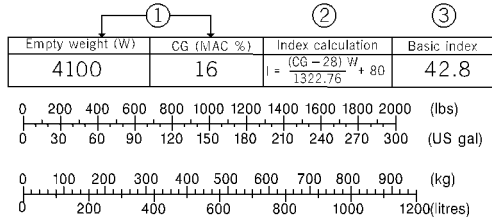
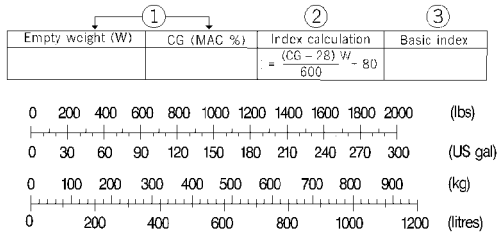

Figure 6.4.1 - LOADING SAMPLE (in Kg and Litres)



14080000AAAADMA18203



Empty weight	INDEX
Front seats	100 kg
Inter. seats	50 kg
Rear bench	50 kg
Baggage in cabin	20 kg
Rear baggage	10 kg
Zero fuel weight	M7FW 2722 kg
Fuel (kg)	NO EFFECT
Fueling (L)	
TOTAL	MTOW 2984 kg

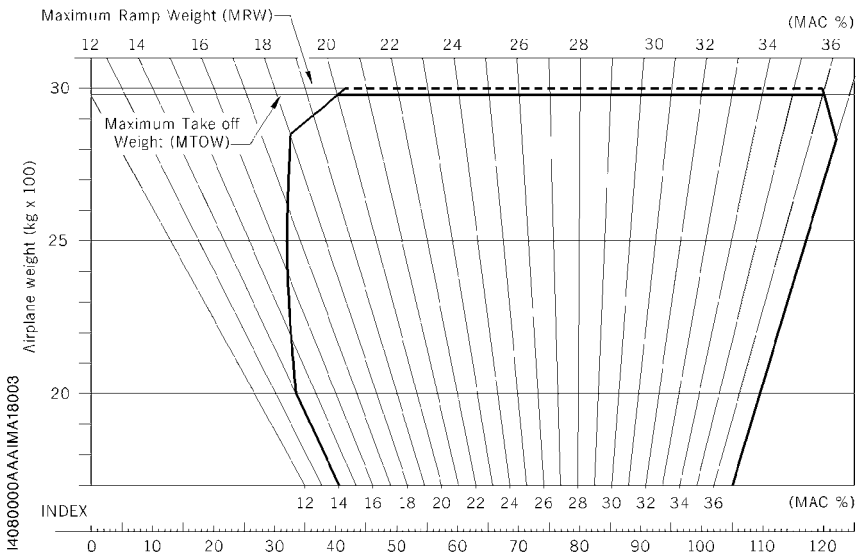
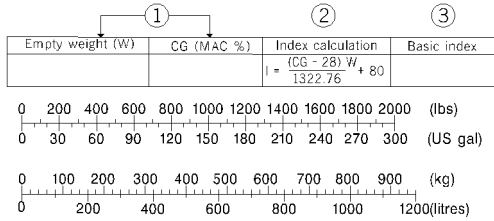

Figure 6.4.2 - WEIGHT AND BALANCE GRAPH (in Kg and Litres)



Empty weight	INDEX	
	10 20 30 40 50 60 70 80 90 100 110 120	
Front seats	200 lbs	
Inter. seats	100 lbs	
Rear bench	100 lbs	
Baggage in cabin	50 lbs	
Rear baggage	20 lbs	
Zero fuel weight	MZFW 6001 lbs	Fueling (US gal)
Fuel (lbs)	NO EFFECT	
TOTAL	MTOW	
	6579 lbs	

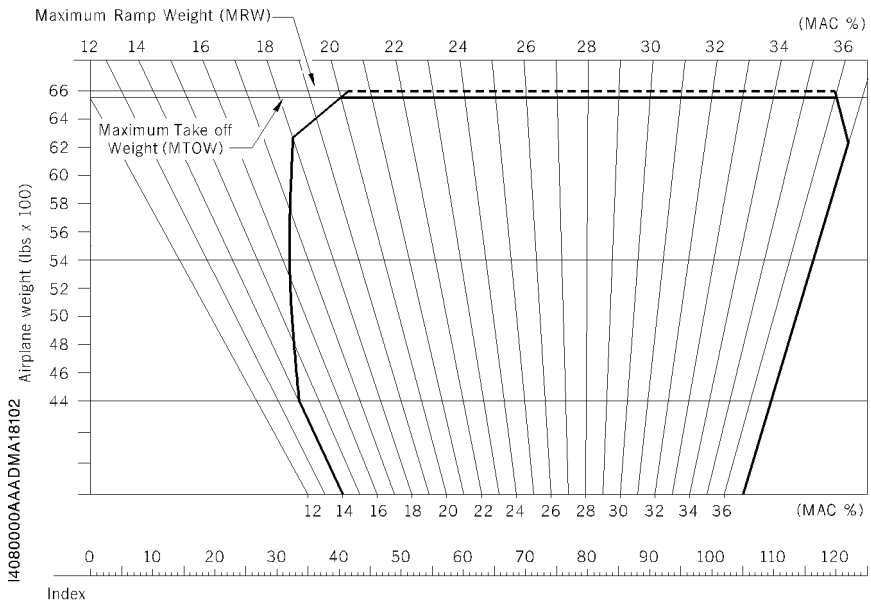

Figure 6.4.2A - WEIGHT AND BALANCE GRAPH (in lbs and us gal)

DETERMINING EMPTY AIRPLANE CHARACTERISTICS

■ (Refer to Supplement 41 for TBM 700C2 airplane)

Empty airplane characteristics (weight and balance) may vary with regard to those indicated on weighing form according to installed optional equipment.

List of equipment (paragraph 6.5) contains the standard and optional equipment, as well as their characteristics (weight, arm).

Use the chart below to compute new empty weight and corresponding balance if necessary.

DATE	EQUIPMENT OR MODIFICATION DESCRIPTION	(+) (-)	WEIGHT MODIFICATION			BASIC EMPTY WEIGHT		
			Weight lb	Arm in.	Moment lb.in/1000	Weight W	Arm "d _o "	Moment
	According to delivery							

Figure 6.4.3 - SAMPLE WEIGHT AND BALANCE RECORD

$$CG \text{ m.a.c.} \% = \frac{(d_o - 172.93)}{59.45} \times 100$$

Use the above formula to express arm "d_o" in % of mean aerodynamic chord.

NOTE :

Arm expressed in inches with regard to reference.

- Front seats : 180.5 in. (4.585 m)
- Intermediate seats : 222.1 in. (5.641 m)
- Rear bench (2 seats) : 272.3 in. (6.916 m)
- Baggage compartment in pressurized cabin : 303.0 in. (7.695 m)
- Aft baggage compartment : 329.4 in. (8.366 m)
- Fuel : 189.8 in. (4.820 m)

INTENTIONALLY LEFT BLANK

6.5 - LIST OF EQUIPMENT

■ (Refer to Supplement 41 for equipment specific for TBM 700C2 airplane)

The following list contains standard equipment installed on each airplane and available optional equipment.

A separate list of equipment of items installed at the factory in your specific airplane is provided in your airplane file.

Columns showing weight (in pounds) and arm (in inches) provide the weight and center of gravity location for the equipment.

In the list of Required, Standard or Optional equipment (not restrictive), a letter "R", "S", "O" or "A" allows classifying the equipment :

"R" : equipment items required for certification

"S" : standard equipment items

"A" : optional equipment items which are in addition to required or standard items

"O" : optional equipment items replacing required or standard items

S/ R/ A/ O	ITEM OPT70 or MOD70	REQUIRED (R) OR STANDARD (S) OR OPTIONAL (A or O) EQUIPMENT	EQUIPMENT SUPPLIER	WEIGHT per unit lb (kg)	ARM in. (m)
		01 - SPECIFIC OPTIONAL EQUIPMENT			
S	01019	DME KN63 shield case	SOCATA	0.33 (0.150)	231.50 (5.880)
S	01026A	Flight ceiling at 31000 ft	SOCATA	/	/
A	01029	Provision for TBM 700C2	SOCATA	112.17 (50.88)	230.83 (5.863)

S/ R/ A/ O	ITEM OPT70 or MOD70	REQUIRED (R) OR STANDARD (S) OR OPTIONAL (A or O) EQUIPMENT	EQUIPMENT SUPPLIER	WEIGHT per unit lb (kg)	ARM in. (m)
		21 - ENVIRONMENTAL SYSTEM			
		21-20 - Distribution			
S		Cabin fan 11-93364	HONEYWELL LMB	7.72 (3.500)	292.72 (7.435)
		21-30 - Pressurization control			
S		Cabin altitude differential pressure and rate of climb indicator 3300-J51 CODE J.51	UNITED INSTRUMENTS	0.94 (0.425)	157.48 (4.000)
S		Cabin altitude warn switch 214 C40.3.261	CONDEC/ EATON	0.08 (0.035)	153.94 (3.910)
S		Cabin pressurization dump solenoid valve 5112-1	AEROSPACE	0.44 (0.200)	181.10 (4.600)
S		Cabin ΔP warn switch 17-600-01	UMA	0.14 (0.065)	139.76 (3.550)
S		Check valve 985C-63-3	LE BOZEC	0.20 (0.090)	118.11 (3.000)
S		Outflow valve controller 130618-1	GARRETT	1.65 (0.750)	157.48 (4.000)
S		Outflow valve 103760-1	GARRETT	1.54 (0.700)	317.32 (8.060)
S		Safety valve 103760-2	GARRETT	1.54 (0.700)	317.32 (8.060)
		21-50 - Temperature conditioning system			
S		Duct overtemperature switch 6084C000-001	NORMALAIR GARRETT	0.14 (0.065)	129.37 (3.286)
S		Heat exchanger/cooling turbine pack 6053C000-003	NORMALAIR GARRETT	18.96 (8.600)	109.84 (2.790)
S		Overpressure switch 6085C000-001	NORMALAIR GARRETT	0.19 (0.086)	115.51 (2.934)

S/ R/ A/ O	ITEM OPT70 or MOD70	REQUIRED (R) OR STANDARD (S) OR OPTIONAL (A or O) EQUIPMENT	EQUIPMENT SUPPLIER	WEIGHT per unit lb (kg)	ARM in. (m)
S		Overtemperature switch 6083C000-001	NORMALAIR GARRETT	0.14 (0.065)	107.95 (2.742)
S		Pressure regulator and shut-off valve 4350B000-002	NORMALAIR GARRETT	3.09 (1.400)	114.25 (2.902)
S		Water separator 6055C000-002	NORMALAIR GARRETT	2.05 (0.930)	97.80 (2.484)
21-55 - Vapor cycle cooling system					
S		Compressor/condenser pack 11-92364	SECAN	55.12 (25.000)	125.39 (3.185)
S		Evaporator 11-91364	SECAN	11.02 (5.000)	309.45 (7.860)
21-60 - Temperature regulation					
S		Temperature control valve 6094C000-001	NORMALAIR GARRETT	2.50 (1.134)	113.15 (2.874)
S		Controller 6054C000-001	NORMALAIR GARRETT	2.43 (1.100)	133.31 (3.386)
S		Duct temperature sensor 6080C000-001	NORMALAIR GARRETT	0.11 (0.048)	130.87 (3.324)
S		Cabin temperature sensor 6080C000-001	NORMALAIR GARRETT	0.11 (0.048)	303.54 (7.710)

S/ R/ A/ O	ITEM OPT70 or MOD70	REQUIRED (R) OR STANDARD (S) OR OPTIONAL (A or O) EQUIPMENT	EQUIPMENT SUPPLIER	WEIGHT per unit lb (kg)	ARM in. (m)	
		22 - AUTO FLIGHT				
		<i>NOTE :</i> <i>KFC 325 autopilot is included in</i> <i>EFIS equipment (ATA 34)</i>				
S		AFC air data computer P/N 065-00085-0002	KDC 222	HONEYWELL	0.970 (0.440)	167.32 (4.250)
S		AFC computer P/N 065-00064-0008	KCP 220	HONEYWELL	3.086 (1.400)	171.26 (4.350)
S		AFC mode selector P/N 065-00086-0008	KMC 321	HONEYWELL	0.882 (0.400)	155.51 (3.950)
S		Amplifier separator	KA 21	SOCATA	1.279 (0.580)	194.88 (4.950)
S		Audio alerter P/N 071-01466-0000	KAA 15	HONEYWELL	0.750 (0.340)	171.26 (4.350)
S		Pitch servo P/N 065-00061-0050	KS 270A	HONEYWELL	2.601 (1.180)	247.44 (6.285)
S		Pitch trim servo P/N 065-00059-0023	KS 272A	HONEYWELL	2.403 (1.090)	157.48 (4.000)
S		Roll servo P/N 065-00060-0001	KS 271A	HONEYWELL	2.403 (1.090)	227.76 (5.785)
S		Yaw servo P/N 065-00060-0000	KS 271A	HONEYWELL	2.403 (1.090)	253.74 (6.445)
S		Yaw rate gyro P/N 060-00024-0000	KRG 331	HONEYWELL	0.750 (0.340)	171.26 (4.350)
S	22002	Altitude and vertical speed preselector with warning at ± 200 ft	KAS 297C	HONEYWELL	1.124 (0.510)	155.51 (3.950)

S/R/A/O	ITEM OPT70 or MOD70	REQUIRED (R) OR STANDARD (S) OR OPTIONAL (A or O) EQUIPMENT	EQUIPMENT SUPPLIER	WEIGHT per unit lb (kg)	ARM in. (m)
23 - COMMUNICATIONS					
S		Antenna 16-21B-P3 (under fuselage)	CHELTON	1.04 (0.470)	272.28 (6.916) or 280.31 (7.120)
S		Cockpit loud-speaker AB 100 SC	ALPINE ELECTRONICS	0.77 (0.350)	181.10 (4.600)
S		Static dischargers Type 2-16SC-1	CHELTON	Neglig.	/
S		Warning loud-speaker AD 2071/Z8	PHILIPS	0.11 (0.050)	181.10 (4.600)
A	23009A	Additional equipment for electrostatic dischargers	CHELTON	Neglig.	/
S	23011F	Radio stereo-headset Serie X	BOSE	/	/
O	23011G	Radio stereo-headset HMEC 25-6A	SENNHEISER	/	/
A	23012B	Audio-Marker PMA 7000-MS (with EFIS equipment)	PS ENGINEERING	1.43 (0.650)	151.57 (3.850)
O	23017C	COM1-NAV#1 KX 165A with EFIS (with KN40 converter)	HONEYWELL	3.99 (1.810)	153.54 (3.900)
O	23022C	COM1-NAV#2 KX 165A with EFIS	HONEYWELL	3.99 (1.810)	153.54 (3.900)
O	23023	Audio-Marker GMA340 with EFIS	GARMIN	1.46 (0.660)	153.54 (3.900)
A	23024	COM/NAV/GPS # 1 (B-RNAV) GNS530 system with EFIS : Version A (antenna forward of frame 7)			
		. Transceiver GNS530	GARMIN	8.49 (3.850)	151.57 (3.850)
		. VHF antenna (under fuselage) 16-21B-P3	CHELTON	0.86 (0.390)	271.65 (6.900)

S/ R/ A/ O	ITEM OPT70 or MOD70	REQUIRED (R) OR STANDARD (S) OR OPTIONAL (A or O) EQUIPMENT	EQUIPMENT SUPPLIER	WEIGHT per unit lb (kg)	ARM in. (m)	
A	23024 (Cont'd)	Version A (Cont'd)				
		. GPS antenna KA 92	HONEYWELL	0.26 (0.120)	196.85 (5.000)	
		or GA 56	GARMIN	0.46 (0.210)	196.85 (5.000)	
		Version B (antenna rearward of frame 7) - From S/N 312				
		. Transceiver GNS530	GARMIN	8.49 (3.850)	151.57 (3.850)	
		. VHF antenna (under fuselage) 16-21B-P3	CHELTON	0.86 (0.390)	271.65 (6.900)	
		. GPS antenna GA 56	GARMIN	0.46 (0.210)	204.84 (5.203)	
		Version C (antenna rearward of frame 7) - From S/N 312				
		. Transceiver GNS530	GARMIN	8.49 (3.850)	151.57 (3.850)	
		. VHF antenna (under fuselage) 16-21B-P3	CHELTON	0.86 (0.390)	271.65 (6.900)	
		. GPS antenna GA 56A	GARMIN	0.46 (0.210)	204.84 (5.203)	
		23025	COM/NAV/GPS # 2 (B-RNAV) system with EFIS, interfaced with GI 106A CDI and EHSI : Version A (antenna in aircraft centerline)			
			. Transceiver GNS530	GARMIN	8.49 (3.850)	151.57 (3.850)
			. VHF antenna (upper fuselage) 16-21B-P3	CHELTON	0.86 (0.390)	271.65 (6.900)
. GPS antenna KA 92	HONEYWELL		0.26 (0.120)	204.72 (5.200)		
or GA 56	GARMIN		0.46 (0.210)	204.72 (5.200)		

SECTION 6
WEIGHT AND BALANCE

S/ R/ A/ O	ITEM OPT70 or MOD70	REQUIRED (R) OR STANDARD (S) OR OPTIONAL (A or O) EQUIPMENT	EQUIPMENT SUPPLIER	WEIGHT per unit lb (kg)	ARM in. (m)
	23025 (Cont'd)	. CDI GI 106A Version B (antenna on R.H. side of aircraft centerline) - From S/N 312	MID CONTINENT	1.46 (0.660)	155.51 (3.950)
		. Transceiver GNS530	GARMIN	8.49 (3.850)	151.57 (3.850)
		. VHF antenna (upper fuselage) 16-21B-P3	CHELTON	0.86 (0.390)	271.65 (6.900)
		. GPS antenna GA 56	GARMIN	0.46 (0.210)	204.84 (5.203)
		. CDI GI 106A Version C (antenna on R.H. side of aircraft centerline) - From S/N 312	MID CONTINENT	1.46 (0.660)	155.51 (3.950)
		. Transceiver GNS530	GARMIN	8.49 (3.850)	151.57 (3.850)
		. VHF antenna (upper fuselage) 16-21B-P3	CHELTON	0.86 (0.390)	271.65 (6.900)
		. GPS antenna GA 57	GARMIN	0.46 (0.210)	204.84 (5.203)
		. CDI GI 106A Version E (antenna on R.H. side of aircraft centerline) - From S/N 312	MID CONTINENT	1.46 (0.660)	155.51 (3.950)
		. Transceiver GNS530	GARMIN	8.49 (3.850)	151.57 (3.850)
		. VHF antenna (upper fuselage) 16-21B-P3	CHELTON	0.86 (0.390)	271.65 (6.900)
		. GPS antenna GA 56A	GARMIN	0.46 (0.210)	204.84 (5.203)
		. CDI GI 106A	MID CONTINENT	1.46 (0.660)	155.51 (3.950)

S/ R/ A/ O	ITEM OPT70 or MOD70	REQUIRED (R) OR STANDARD (S) OR OPTIONAL (A or O) EQUIPMENT	EQUIPMENT SUPPLIER	WEIGHT per unit lb (kg)	ARM in. (m)
A	23026	VHF Data Link KDR510 Version A (antenna under wing)	HONEYWELL	2.45 (1.113)	191.69 (4.869)
A	0214-23	Receiver GDL 69A Coupled with MFD GMX 200 and Audio Marker GMA 340 - From S/N 312 (equipped with OPT70 23025 GNS 530 # 2 Version C) (Valid for US and CANADA)	GARMIN	2.80 (1.27)	204.72 (5.200)

S/ R/ A/ O	ITEM OPT70 or MOD70	REQUIRED (R) OR STANDARD (S) OR OPTIONAL (A or O) EQUIPMENT	EQUIPMENT SUPPLIER	WEIGHT per unit lb (kg)	ARM in. (m)
		24 - ELECTRICAL POWER			
		24-30 - DC generation			
R		Ammeter AM99-05	FALGAYRAS	0.31 (0.140)	175.20 (4.450)
R		Electric power center (Freon + ignition priority + contact splitting) 160GC02Y05	ECE	11.02 (5.000)	127.95 (3.250)
R		Stand-by generator T700A243008000601	SOCATA	12.13 (5.500)	102.36 (2.600)
R		Starter generator 8012F	AUXILEC	24.47 (11.100)	110.24 (2.800)
R		Voltmeter VT99-04	FALGAYRAS	0.22 (0.100)	175.20 (4.450)
O	24001A	Battery 4076-1	SAFT	83.33 (37.800)	112.00 (2.845)
S	24002A	Lead-Acid battery RG-380E/44	CONCORDE	85.98 (39.000)	112.20 (2.850)
A	0303-24	Charger/Maintainer for lead acid battery (Airplanes equipped with OPT70 24002)		0.220 (0.100)	114.17 (2.900)
		24-40 - External power supply			
S		Ground power receptacle MS 3506-1	QPL (AIRCRAFT APPLIANCES AND EQUI. LTD)	0.79 (0.360)	114.17 (2.900)

S/ R/ A/ O	ITEM OPT70 or MOD70	REQUIRED (R) OR STANDARD (S) OR OPTIONAL (A or O) EQUIPMENT	EQUIPMENT SUPPLIER	WEIGHT per unit lb (kg)	ARM in. (m)
25 - EQUIPMENT AND FURNISHINGS					
A	25004D	Leather upholstery - version D "Autolux"	SOCATA	6.614 (3.000)	212.60 (5.400)
A	0386-25	Leather upholstery "Vulcain"	SOCATA	6.614 (3.000)	212.60 (5.400)
A	25005D	JEPPESEN filing cabinet	SOCATA	16.09 (7.300)	202.76 (5.150)
A	25006G	Storage box - Composite (wood and leather)	SOCATA	17.64 (8.000)	202.76 (5.150)
A	25006H	Refreshment cabinet - Composite (wood and leather)	SOCATA	20.28 (9.200)	202.76 (5.150)
A	25009G	BECKER audio cabinet	SOCATA	26.23 (11.900)	225.43 (5.726)
A	0171-25	"Generation 2005" cabinets - From S/N 328		9.48	203.74
		- Vers. A : L.H. low cabinet		(4.300)	(5.175)
				9.48	203.74
		- Vers. B : R.H. low cabinet		(4.300)	(5.175)
				9.48	203.74
		- Vers. C : Removable (low) insu- lated picnic bag		(4.300)	(5.175)
				7.72	203.74
		- Vers. D : L.H. top storage cabinet		(3.500)	(5.175)
				7.72	203.74
		- Vers. E : R.H. top storage cabinet		(3.500)	(5.175)
				7.94	203.74
		- Vers. F : R.H. top storage cabinet + audio		(3.600)	(5.175)
				3.09	203.74
		- Vers. G : L.H. top baggage cabinet		(1.400)	(5.175)
				3.09	203.74
		- Vers. H : R.H. top baggage cabinet		(1.400)	(5.175)
S		Map holder	SOCATA	0.46 (0.210)	167.72 (4.260)
O		LED lighted chart holder	MADELEC SYSTEM	0.595 (0.270)	/

S/ R/ A/ O	ITEM OPT70 or MOD70	REQUIRED (R) OR STANDARD (S) OR OPTIONAL (A or O) EQUIPMENT	EQUIPMENT SUPPLIER	WEIGHT per unit lb (kg)	ARM in. (m)
A	25024B	Carpet protecting mat	SOCATA	5.73 (2.600)	246.10 (6.250)
A	25024C	Carpet protecting mat	SOCATA	4.19 (1.900)	246.10 (6.250)
O	25025C	Cabin furnishings "Black chromé"	SOCATA	Δ 1.98 (Δ 0.900)	314.64 (7.992)
O	25025D	Cabin furnishings "Doré"	SOCATA	Δ 1.98 (Δ 0.900)	314.64 (7.992)
S	25026A	Partition net between the cabin and the baggage compartment	SOCATA	2.76 (1.250)	289.53 (7.354)
A	25027A	Cargo transportation capability (pilot alone on board)	SOCATA	25.35 (11.500)	246.69 (6.266)
A	25027B	Cargo transportation capability (1 pilot + 1 front passenger)	SOCATA	30.86 (14.000)	246.10 (6.251)
A	25032	Front seats ease covers	SOCATA	2.76 (1.250)	183.78 (4.668)
A	0151-25	CD reader PCD 7100	PS ENGINEERING	2.20 (1.000)	205.04 (5.208)
A	0174-25	Optional 12 V plugs	SOCATA	3.31 (1.500)	195.28 (4.960)
A	0246-25B	Potty seat (Chemical toilets cabinet) and its associated curtain)	DOMETIQUE/ CATHERINEAU	54.23 (24.600)	219.96 (5.587)

S/ R/ A/ O	ITEM OPT70 or MOD70	REQUIRED (R) OR STANDARD (S) OR OPTIONAL (A or O) EQUIPMENT	EQUIPMENT SUPPLIER	WEIGHT per unit lb (kg)	ARM in. (m)
		Seats - Belts (Standard equipment)			
S		Seats (6 places with or without oxygen equipment) - Post-MOD70-019-25			
O		. Pilot's seat T700A2512082	PPI	29.696 (13.470)	182.68 (4.640)
O		. Front R.H. seat T700A2512082	PPI	29.696 (13.470)	182.68 (4.640)
S		. Intermediate seats (R.H. and L.H.) (back to flight direction) T700A2522004	PPI	25.507 (11.570)	218.31 (5.545)
O		. Rear divan T700B2520018	PPI	57.319 (26.000)	271.30 (6.891)
		Leather seats - Belts			
S		. Pilot's seat T700A2512082	SOCATA	27.56 (12.500)	182.68 (4.640)
S		. Front R.H. Seat T700A2512082	SOCATA	27.56 (12.500)	182.68 (4.640)
S		. L.H. Intermediate seat (back to flight direction) T700A2522004	SOCATA	24.25 (11.000)	218.30 (5.545)
S		. R.H. Intermediate seat (back to flight direction) T700A2522004	SOCATA	24.25 (11.000)	218.30 (5.545)
S		. Double chair, L .H. Seat T700B2520015	SOCATA	25.35 (11.500)	271.30 (6.891)
S		. Double chair, R. H. seat T700B2520015	SOCATA	25.35 (11.500)	271.30 (6.891)
S		Reels	ANJOU AERONAUTIQUE	1.79 (0.810)	192.91 or 287.40 (4.900 or 7.300)

S/ R/ A/ O	ITEM OPT70 or MOD70	REQUIRED (R) OR STANDARD (S) OR OPTIONAL (A or O) EQUIPMENT	EQUIPMENT SUPPLIER	WEIGHT per unit lb (kg)	ARM in. (m)
		25-61 - Emergency locator transmitter			
S	25030A	Three-frequency emergency locator transmitter C406-1 (with base) (Nav interface and GPS coupled), of which :	ARTEX	7.63 (3.459)	350.39 (8.900)
		. ELT C406-1	ARTEX	3.36 (1.525)	354.72 (9.010)
		. ELT/NAV interface box 453-6500	ARTEX	2.69 (1.220)	353.15 (8.970)
		. Antenna 21-41	CHELTON	0.31 (0.140)	318.70 (8.095)
O	25030B	Three-frequency emergency locator transmitter C406-1 (with base and reinforcement) (Nav interface and GPS coupled), of which :	ARTEX	7.63 (3.459)	350.39 (8.900)
		. ELT C406-1	ARTEX	3.36 (1.525)	354.72 (9.010)
		. ELT/NAV interface box 453-6500	ARTEX	2.69 (1.220)	353.15 (8.970)
		. Antenna 21-41	CHELTON	0.31 (0.140)	318.70 (8.095)
O	0153-25A	Emergency beacon KANNAD 406AF (installed in tail area) (with support)	SERPE-IESM	2.45 (1.110)	347.09 (8.816)
		. ELT/NAV interface box CS144A	SERPE-IESM	1.81 (0.823)	347.09 (8.816)
		. Antenna 21-41	CHELTON	0.31 (0.140)	339.37 (8.620)

S/ R/ A/ O	ITEM OPT70 or MOD70	REQUIRED (R) OR STANDARD (S) OR OPTIONAL (A or O) EQUIPMENT	EQUIPMENT SUPPLIER	WEIGHT per unit lb (kg)	ARM in. (m)
O	0153-25C	Emergency beacon KANNAD 406AF (installed in tail area) (with support)	SERPE-IESM	2.45 (1.110)	347.09 (8.816)
		. ELT/NAV interface box CS144A	SERPE-IESM	1.81 (0.823)	347.09 (8.816)
		. Antenna 1327-82	CHELTON	0.33 (0.150)	339.37 (8.620)

S/ R/ A/ O	ITEM OPT70 or MOD70	REQUIRED (R) OR STANDARD (S) OR OPTIONAL (A or O) EQUIPMENT	EQUIPMENT SUPPLIER	WEIGHT per unit lb (kg)	ARM in. (m)
26 - FIRE PROTECTION					
S	26001B	Portable fire extinguisher unit 863520-00	L'HOTELLIER	3.64 (1.650)	192.16 (4.881)
A	26002B	Engine fire detection system	L'HOTELLIER	1.45 (0.660)	96.06 (2.440)
A	0391-26	Portable fire extinguisher unit 74-00	AIR TOTAL		
		Version A	AIR TOTAL	4.89 (2.220)	170.11 (4.321)
		Version B	AIR TOTAL	4.89 (2.220)	192.16 or 194.16 (4.881 or 4.932)
		Version C	AIR TOTAL	4.96 (2.250)	193.80 (4.923)

S/ R/ A/ O	ITEM OPT70 or MOD70	REQUIRED (R) OR STANDARD (S) OR OPTIONAL (A or O) EQUIPMENT	EQUIPMENT SUPPLIER	WEIGHT per unit lb (kg)	ARM in. (m)
		27 - FLIGHT CONTROLS			
		27-10 - Roll control			
R		Roll trim actuator 145700.02	LPMI	1.54 (0.700)	212.60 (5.400)
		27-20 - Yaw control			
R		Rudder trim actuator 145700.02	LPMI	1.54 (0.700)	395.27 (10.040)
R		Trim and flap indicator 4724	PEKLY S.A	1.10 (0.500)	159.45 (4.050)
S		AFC and electric trim control on R.H. control wheel	SOCATA	0.88 (0.400)	157.48 (4.000)
		27-30 - Pitch control			
S		Pitch trim actuator 145400-02	LPMI	1.21 (0.550)	425.20 (10.800)
		27-50 - Wing flaps (control)			
R		Flap control including :	AVIAC	15.52 (7.040)	218.50 (5.550)
		. Flap motor 6157-1	AVIAC	2.87 (1.300)	216.54 (5.500)
		. Flap actuator 1-5295/2-5295 or 1-5297/2-5297	AVIAC	1.92 (0.870) 1.83 (0.830)	216.54 (5.500) 220.47 (5.600)

S/ R/ A/ O	ITEM OPT70 or MOD70	REQUIRED (R) OR STANDARD (S) OR OPTIONAL (A or O) EQUIPMENT	EQUIPMENT SUPPLIER	WEIGHT per unit lb (kg)	ARM in. (m)
		28 - FUEL SYSTEM			
		28-20 - Fuel supply			
R		Electric boost pump 2022-B	WELDON	3.48 (1.580)	129.92 (3.300)
R		Electric boost pump 1B9-5	AIRBORNE	4.41 (2.000)	129.92 (3.300)
R		Engine driven fuel pump 1127-01A	IN-LHC	1.54 (0.700)	110.24 (2.800)
R		Engine driven fuel pump 1127-02	IN-LHC	1.54 (0.700)	110.24 (2.800)
R		Fuel unit L88A15-651	INTER- TECHNIQUE	4.59 (2.080)	133.07 (3.380)
R		A35 fuel sequencer unit	TFE	1.10 (0.500)	125.98 (3.200)
		28-40 - Fuel indication			
R		Amplifier indicator (in us gal) 748-859-2	INTER- TECHNIQUE	1.48 (0.670)	157.48 (4.000)
R		Fuel pressure indicator PC99-06	FALGAYRAS	0.31 (0.140)	157.48 (4.000)
R		Inboard L.H. gage 768-403 or 762438.1.0	INTER- TECHNIQUE	0.33 (0.150)	183.07 (4.650)
R		Inboard R.H. gage 768-404 or 762439.1.0	INTER- TECHNIQUE	0.33 (0.150)	183.07 (4.650)
R		Intermediate gage 766-976-1 or 762440.1.0	INTER- TECHNIQUE	0.22 (0.100)	190.94 (4.850)
R		Outboard gage 766-977-1 or 762441.1.0	INTER- TECHNIQUE	0.22 (0.100)	190.94 (4.850)
R		Low level sensor 722-447	INTER- TECHNIQUE	0.10 (0.045)	183.07 (4.650)
O	0427-28A	Low level sensor 747-971-1-0	ZODIAC/INTER- TECHNIQUE	0.143 (0.065)	192.91 (4.900)

S/ R/ A/ O	ITEM OPT70 or MOD70	REQUIRED (R) OR STANDARD (S) OR OPTIONAL (A or O) EQUIPMENT	EQUIPMENT SUPPLIER	WEIGHT per unit lb (kg)	ARM in. (m)
30 - ICE AND RAIN PROTECTION					
S		Deicer, L.H. horizontal stabilizer T700A3013003000	SOCATA	4.19 (1.900)	398.42 (10.120)
S		Deicer, R.H. horizontal stabilizer T700A3013003001	SOCATA	4.19 (1.900)	398.42 (10.120)
S		Deicer, vertical stabilizer T700A3014003000	SOCATA	3.97 (1.800)	374.02 (9.500)
S		Deicer, inboard L.H. wing T700A3010001002	SOCATA	5.73 (2.600)	173.23 (4.400)
S		Deicer, inboard R.H. wing T700A3010001003	SOCATA	5.73 (2.600)	173.23 (4.400)
S		Deicer, middle L.H. wing T700A3010001004	SOCATA	3.75 (1.700)	173.23 (4.400)
S		Deicer, middle R.H. wing T700A3010001005	SOCATA	3.75 (1.700)	173.23 (4.400)
S		Deicer, outboard L.H. wing T700A3010012000	SOCATA	2.65 (1.200)	173.23 (4.400)
S		Deicer, outboard R.H. wing T700A3010001007	SOCATA	3.31 (1.500)	173.23 (4.400)
S		Dual port distribution valve 1532-10C	LUCAS	2.43 (1.100)	125.98 (3.200)
S		Timer 42E25-2A	LUCAS	0.77 (0.350)	177.17 (4.500)
S		Water separator and filter 44E21-2A	LUCAS	1.10 (0.500)	125.98 (3.200)
30-40 - Windshield deicing					
S		Windshield heater controller TWH 93-01	AIR SYSTEMS	0.99 (0.450)	149.61 (3.800)

S/ R/ A/ O	ITEM OPT70 or MOD70	REQUIRED (R) OR STANDARD (S) OR OPTIONAL (A or O) EQUIPMENT	EQUIPMENT SUPPLIER	WEIGHT per unit lb (kg)	ARM in. (m)
		30-60 - Propeller deicing			
S		Modular brush assy 3E2044-2	BF GOODRICH	0.44 (0.200)	47.05 (1.195)
S		Timer 3E2311-4	BF GOODRICH	0.44 (0.200)	200.79 (5.100)

S/ R/ A/ O	ITEM OPT70 or MOD70	REQUIRED (R) OR STANDARD (S) OR OPTIONAL (A or O) EQUIPMENT	EQUIPMENT SUPPLIER	WEIGHT per unit lb (kg)	ARM in. (m)
		31 - INDICATING/RECORDING SYSTEMS			
		31-20 - Independent instruments			
S		Chronometer 420000	ASTROTECH	0.15 (0.070)	157.48 (4.000)
O	31001A	Stop watch Q18-945-22-28-1-LE	THOMMEN	0.42 (0.190)	157.48 (4.000)
O	31002A	Hourmeter 56457-3 (engine running time)	DATCON	0.55 (0.250)	156.30 (3.970)
O	31002B	Hourmeter 56457-3 (flying time)	DATCON	0.55 (0.250)	156.30 (3.970)
		31-50 - Aural warning			
R		Aural warning system T700A3155011000	SOCATA	0.66 (0.300)	183.07 (4.650)
		31-60 - Visual warning			
R		Advisory panel AP 00-06	AIR SYSTEMS	4.41 (2.000)	157.48 (4.000)

S/ R/ A/ O	ITEM OPT70 or MOD70	REQUIRED (R) OR STANDARD (S) OR OPTIONAL (A or O) EQUIPMENT	EQUIPMENT SUPPLIER	WEIGHT per unit lb (kg)	ARM in. (m)
		32 - LANDING GEARS			
		32-10 - Main landing gear			
R		L.H. main landing gear 21135-002-00	ERAM	50.044 (22.700)	200.39 (5.090)
R		R.H. main landing gear 21136-002-00	ERAM	50.044 (22.700)	200.39 (5.090)
O	0141-32	L.H. main landing gear D23767000	MESSIER DOWTY	51.59 (23.400)	200.39 (5.090)
O	0141-32	R.H. main landing gear D23768000	MESSIER DOWTY	51.59 (23.400)	200.39 (5.090)
		32-20 - Nose landing gear			
R		Nose gear 21130-001-00	ERAM	52.910 (24.000)	93.70 (2.380)
O	0141-32	Nose gear D23766000	MESSIER DOWTY	53.57 (24.300)	93.70 (2.380)
		32-30 - Extension and retraction			
R		Door actuator EC 6230	HRL	1.35 (0.610)	192.91 (4.900)
R		Main locking actuator 08-1480	HRL	13.23 (6.000)	208.07 (5.285)
R		Nose locking actuator 08-1480	HRL	13.23 (6.000)	110.24 (2.800)
R		Hand pump 914-8D27	TELEDYNE	2.33 (1.055)	181.10 (4.600)
A	0342-52	Lower main landing gear doors (R.H. and L.H.)	SOCATA	6.61 (3.000)	204.33 (5.190)

S/ R/ A/ O	ITEM OPT70 or MOD70	REQUIRED (R) OR STANDARD (S) OR OPTIONAL (A or O) EQUIPMENT	EQUIPMENT SUPPLIER	WEIGHT per unit lb (kg)	ARM in. (m)
		32-35 - Hydraulic generation			
R		Hydraulic power pack :	LHC		
		- from S/N 11 to S/N 227 : 1118-03		6.548 (2.970)	84.65 (2.150)
	060-32	- from S/N 228 : 1118-04		10.362 (4.700)	84.65 (2.150)
		32-40 - Wheels and brakes			
R		Brake assembly 030-19100	PARKER	14.99 (6.800)	204.33 (5.190)
R		Main tire 18x5.5-8/190T	MICHELIN	12.20 (5.534)	204.33 (5.190)
R		Main tire 18x5.5-8PR FLE	GOODYEAR	13.45 (6.101)	204.33 (5.190)
R		Master cylinder 010-07801	PARKER	0.88 (0.400)	145.67 (3.700)
R		Master cylinder 010-07802	PARKER	0.88 (0.400)	145.67 (3.700)
R		Nose tire 5.00x5-6PR	DUNLOP	6.400 (2.903)	89.57 (2.275)
R		Nose tire 5.00-5-10PR TL	MICHELIN	6.000 or 5.600 (2.722 or 2.540)	89.57 (2.275)
R		Nose tire 5.00-5-10PR TL	GOODYEAR	6.30 (2.858)	89.57 (2.275)
R	0408-32	Nose tire 5.00-5-10PR	GOODYEAR	6.83 (3.100)	89.57 (2.275)
R		Nose wheel 40-262A	PARKER	2.98 (1.350)	89.57 (2.275)

SECTION 6
WEIGHT AND BALANCE

S/ R/ A/ O	ITEM OPT70 or MOD70	REQUIRED (R) OR STANDARD (S) OR OPTIONAL (A or O) EQUIPMENT	EQUIPMENT SUPPLIER	WEIGHT per unit lb (kg)	ARM in. (m)
R		Main wheel 040-27000	PARKER	11.02 (5.000)	204.33 (5.190)
R		Parking brake valve T700A3240010 or T700B3240001	SOCATA	0.33 (0.150)	157.48 (4.000)

S/ R/ A/ O	ITEM OPT70 or MOD70	REQUIRED (R) OR STANDARD (S) OR OPTIONAL (A or O) EQUIPMENT	EQUIPMENT SUPPLIER	WEIGHT per unit lb (kg)	ARM in. (m)
33 - LIGHTS					
33-10 - Instrument panel lighting					
S		L.H. tube 67135 U290 C62S	SELA	Neglig.	/
S		R.H. tube 67135 U290 C63S	SELA	Neglig.	/
S		DC/AC inverter T700A3310021	SOCATA	0.33 (0.150)	153.54 (3.900)
S		Intensity control T700A3310022	SOCATA	0.22 (0.100)	157.48 (4.000)
S		Instruments emergency lighting 2240-3	WEMAC	0.11 (0.050)	181.10 (4.600)
A	33001A	PULSELITE unit 1NC P/N 1220/2410-2 (for landing lights)	PRECISE FLIGHT	1.27 (0.574)	202.60 (5.146)
33-40 - External lighting					
S		L.H. wing inspection light (icing detection) T700A3340012	SOCATA	0.20 (0.090)	151.57 (3.850)
S		Landing lights 4596	GE	0.79 (0.360)	179.13 (4.550)
S		Taxi light assy T700A3340006	SOCATA	1.10 (0.500)	93.70 (2.380)
S		NAV/Anticollision system With bulb strobe/nav lights :			
S		- Anticollision power supply A413A HDA-CF-14/28	WHELEN	3.00 (1.360)	204.72 (5.200)
S		- R.H. or L.H. navigation light assy T700A3341019	SOCATA	0.51 (0.230)	185.04 (4.700)
O	33002	Halogen landing lights Q5596	WHELEN	0.79 (0.360)	179.13 (4.550)
		Halogen taxi light Q5587	WHELEN	1.10 (0.500)	93.70 (2.380)

S/ R/ A/ O	ITEM OPT70 or MOD70	REQUIRED (R) OR STANDARD (S) OR OPTIONAL (A or O) EQUIPMENT	EQUIPMENT SUPPLIER	WEIGHT per unit lb (kg)	ARM in. (m)
		34 - NAVIGATION			
		34-11 - Air data systems			
R		Altimeter # 1 5934 PAD-3 Code A.186	UNITED INSTRUMENTS	0.90 (0.410)	157.48 (4.000)
R		Lift transducer 799-5	SAFE FLIGHT INSTRUMENTS	0.88 (0.400)	173.23 (4.400)
R		Lift transducer 799-8	SAFE FLIGHT INSTRUMENTS	0.88 (0.400)	173.23 (4.400)
S		Pitot heated probe AN 5812-1	QPL (AIRCRAFT APPLIANCES AND EQUI. LTD)	0.75 (0.340)	200.79 (5.100)
R		Static reference plug T700A3415017	SOCATA	Neglig.	/
S		Static reference selector TB30 77010000	SOCATA	0.22 (0.100)	157.48 (4.000)
S		Vertical speed indicator 3" (L.H. Instrument panel) 7060 C.118	UNITED INSTRUMENTS	0.82 (0.370)	157.48 (4.000)
R		V _{MO} ΔP switch 32202-1	HYDRA ELECTRIC	0.22 (0.100)	141.73 (3.600)
S	34011A	Airspeed indicator # 1 8140 Code B.666	UNITED INSTRUMENTS	0.75 (0.340)	157.48 (4.000)
O	34012A	Servoed encoding altimeter # 1 KEA 346	KING	3.09 (1.400)	153.15 (3.890)
S	34018A	Vertical speed indicator 3" (R.H. instrument panel) 7060 C118	UNITED INSTRUMENTS	0.82 (0.370)	157.48 (4.000)
A	34019A	Airspeed indicator # 2 8040 Code B.617 (R.H. instrument panel)	UNITED INSTRUMENTS	0.93 (0.420)	154.96 (3.936)
A	34019B	TAS Airspeed indicator # 2 8140 Code B.666 (R.H. instrument panel)	UNITED INSTRUMENTS	0.75 (0.340)	157.48 (4.000)

S/ R/ A/ O	ITEM OPT70 or MOD70	REQUIRED (R) OR STANDARD (S) OR OPTIONAL (A or O) EQUIPMENT	EQUIPMENT SUPPLIER	WEIGHT per unit lb (kg)	ARM in. (m)
O	34053	Encoding altimeter # 2 KEA 130A (R.H. instrument panel)	KING	0.79 (0.360)	156.89 (3.985)
O	0159-34	Installation of two altimeters # 1 and # 2 AM250 (provision for "RVSM") - Version A (Standard altimeter # 2 replaced) - Version B (Standard altimeter # 2 kept)	AMETEK	 $\Delta +3.02$ ($\Delta+1.37$) $\Delta +4.10$ ($\Delta+1.86$)	 153.54 (3.900) 153.54 (3.900)
		34-13 - Outside temperature			
S		Outside air temperature indicator 301C	DAVTRON	0.27 (0.120)	157.48 (4.000)
		34-21 - Heading reference system			
S		Directional gyro KG 102A P/N 060-00015-0000	KING	4.30 (1.950)	192.91 (4.900)
A		Flux valve KMT 112 P/N 071-01052-0000	KING	0.31 (0.140)	181.10 (4.600)
S		HSI Slave KA 51B P/N 071-01242-0006	KING	0.20 (0.090)	153.54 (3.900)
A		HSI indicator KI 525A P/N 066-03046-0007	KING	3.95 (1.790)	157.48 (4.000)
S	34023B	HSI # 2 KCS 55A (R.H. instrument panel)	HONEYWELL	12.79 (5.800)	153.54 (3.900)
		34-23 - Magnetic compass			
R		Stand-by compass C2350 L4.M23	AIRPATH	0.55 (0.250)	163.39 (4.150)

S/ R/ A/ O	ITEM OPT70 or MOD70	REQUIRED (R) OR STANDARD (S) OR OPTIONAL (A or O) EQUIPMENT	EQUIPMENT SUPPLIER	WEIGHT per unit lb (kg)	ARM in. (m)
		34-24 - ADI and standby horizon			
A	34002E	Additional horizon 1100-28LS (7F) (Adjustable pointer) (R.H. instrument panel)	BFG	2.65 (1.200)	153.54 (3.900)
		34-25 - Radio magnetic indication			
S	34020D	RMI # 1 KNI 582 (L.H. instrument panel) EFIS coupled	HONEYWELL	3.00 (1.360)	172.83 (4.390)
		Converter KN 40	HONEYWELL	4.23 (1.920)	257.87 (6.550)
O	34020F	RMI # 1 KNI 582 (L.H. instrument panel) EFIS coupled	HONEYWELL	3.51 (1.590)	161.50 (4.102)
		Converter KN 40	HONEYWELL	4.23 (1.920)	257.87 (6.550)
		34-28 - Electronic flight instrumentation system			
S	34001C	EFIS (EFS 40 + AP KFC 325) - with DME KDI 574 (without KN 40 converter)	KING KING	67.813 (30.760)	125.63 (3.191)
		34-31 - Marker			
S		MARKER antenna DM N27-3	DORNE & MARGOLIN	0.75 (0.340)	129.92 (3.300)
		34-41 - Stormscope			
S	34056A	Stormscope WX 500 EFIS coupled with indicator on GNS 530 or MFD KMD850 or GMX 200, of which :	BF GOODRICH	4.94 (2.240)	232.28 (5.900)
		. Antenna NY163	BF GOODRICH	0.84 (0.380)	311.02 (7.900)

S/ R/ A/ O	ITEM OPT70 or MOD70	REQUIRED (R) OR STANDARD (S) OR OPTIONAL (A or O) EQUIPMENT	EQUIPMENT SUPPLIER	WEIGHT per unit lb (kg)	ARM in. (m)
	34056A (Cont'd)	. Processor WX500	BF GOODRICH	2.27 (1.030)	255.91 (6.500)
		34-42 - Weather radar			
S	34040F	Weather radar RDR 2000 EFIS coupled, with indicator on MFD KMD 850 or GMX 200	HONEYWELL	11.53 (5.230)	173.46 (4.406)
		34-43 - Radioaltimeter			
S	34037F	Radioaltimeter KRA 405B (new version with weight lowering of coaxial cables), EFIS coupled, of which :		8.18 (3.710)	195.82 (4.974)
		. Transceiver KRA 405B	HONEYWELL	2.80 (1.270)	231.18 (5.872)
		. Indicator KNI 415	HONEYWELL	1.70 (0.770)	155.24 (3.943)
		. Antennas (Qty 2) DM 19-2-1	DORNE & MARGOLIN	0.40 (0.180)	182.09 (4.625) and 205.83 (5.228)
A	34037H	Radioaltimeter KRA 405B EFIS coupled (with aural warning and without KNI indicator), of which :		5.73 (2.600)	209.37 (5.318)
		. Transceiver KRA 405B	HONEYWELL	2.80 (1.270)	231.18 (5.872)
		. Antennas (Qty 2) DM 19-2-1	DORNE & MARGOLIN	0.40 (0.180)	182.09 (4.625) and 205.83 (5.228)
A	34037I	Radioaltimeter KRA 405B (new version with weight lowering of coaxial cables), EFIS coupled (without aural warning or KNI 415 indicator), of which :		5.622 (2.550)	209.96 (5.333)
		. Transceiver KRA 405B	HONEYWELL	2.80 (1.270)	231.18 (5.872)

SECTION 6
WEIGHT AND BALANCE

S/ R/ A/ O	ITEM OPT70 or MOD70	REQUIRED (R) OR STANDARD (S) OR OPTIONAL (A or O) EQUIPMENT	EQUIPMENT SUPPLIER	WEIGHT per unit lb (kg)	ARM in. (m)
	340371 (Cont'd)	. Antennas (Qty 2) DM 19-2-1	DORNE & MARGOLIN	0.40 (0.180)	182.09 (4.625) and 205.83 (5.228)
		34-44 - Traffic advisory system			
A	34059A	SKYWATCH HP Traffic advisory system SKY 899 with indicator on MFD KMD 850 or GNS 530, of which :	BF GOODRICH	12.72 (5.770)	151.18 (3.840)
		. Antenna NY164	BF GOODRICH	2.29 (1.040)	218.50 (5.550)
		. Processor TRC899	BF GOODRICH	8.88 (4.030)	133.86 (3.400)
A	34059B	SKYWATCH HP Traffic advisory system SKY 899 TAS/EFIS coupled, with indicator on MFD KMD 850 or GNS 530, of which :	BF GOODRICH	12.72 (5.770)	151.18 (3.840)
		. Antenna NY164	BF GOODRICH	2.29 (1.040)	218.50 (5.550)
		. Processor TRC899	BF GOODRICH	8.88 (4.030)	133.86 (3.400)
A	34061A	TAS + TAWS system KMH 880 (not autonomous) with indicator on MFD KMD 850 or GMX 200, of which :	HONEYWELL	15.63 (7.09)	158.42 (4.024)
		. Processor KMH 880	HONEYWELL	9.68 (4.390)	133.07 (3.380)
		. Control box MD41-1208	MID CONTINENT	5.00 (2.270)	157.08 (3.990)
		. Antenna (upper fuselage) KA 815	HONEYWELL	0.95 (0.430)	218.11 (5.540)
		(under fuselage)		0.95 (0.430)	256.69 (6.520)

S/ R/ A/ O	ITEM OPT70 or MOD70	REQUIRED (R) OR STANDARD (S) OR OPTIONAL (A or O) EQUIPMENT	EQUIPMENT SUPPLIER	WEIGHT per unit lb (kg)	ARM in. (m)
A	34061B	TAS + TAWS system KMH 880 with indicator on MFD KMD 850 or GMX 200 of which :	HONEYWELL	15.89 (7.21)	166.02 (4.217)
		. Processor KMH 880	HONEYWELL	9.68 (4.390)	133.07 (3.380)
		. Control box MD41-1208	MID CONTINENT	5.00 (2.270)	157.08 (3.990)
		. Antenna KA 815 (upper fuselage)	HONEYWELL	0.95 (0.430)	218.11 (5.540)
		(under fuselage)		0.95 (0.430)	256.69 (6.520)
		. Antenna KA 92	HONEYWELL	0.26 (0.120)	196.85 (5.000)
A	34061C	TAS + TAWS system KMH 880 with indicator on MFD KMD 850 or GMX 200 of which :	HONEYWELL	15.65 (7.10)	158.42 (4.024)
		. Processor KMH 880	HONEYWELL	9.68 (4.390)	133.07 (3.380)
		. Control box MD41-1208	MID CONTINENT	5.00 (2.270)	157.08 (3.990)
		. Antenna KA 815 (upper fuselage)	HONEYWELL	0.95 (0.430)	218.11 (5.540)
		(under fuselage)		0.95 (0.430)	256.69 (6.520)
		34-45 - Enhanced Ground Proximity Warning System (EGPWS)			
A	34060A	EGPWS of which :	HONEYWELL	2.535 (1.150)	185.39 (4.709)
		. Antenna KA 92	HONEYWELL	0.26 (0.120)	244.09 (6.200)
		. Computer KGP 560	HONEYWELL	1.37 (0.620)	192.91 (4.900)
		. Control box MD41-1208	MID CONTINENT	0.24 (0.110)	155.51 (3.950)

S/ R/ A/ O	ITEM OPT70 or MOD70	REQUIRED (R) OR STANDARD (S) OR OPTIONAL (A or O) EQUIPMENT	EQUIPMENT SUPPLIER	WEIGHT per unit lb (kg)	ARM in. (m)
		34-51 - NAV 1 installation			
S		GS-NAV VHF antenna DM N4-17N	DORNE & MARGOLIN	3.31 (1.500)	401.57 (10.200)
		34-52 - NAV 2 installation			
S		CDI KI 204	HONEYWELL	1.70 (0.770)	151.57 (3.850)
		34-53 - Transponder			
A	34021G	Transponder # 2 interfaced with encoding altimeter # 2 KT 76C+	HONEYWELL	3.17 (1.440)	150.59 (3.825)
		Antenna KA 60		0.20 (0.090)	157.48 (4.000)
O	34026C	Transponder # 1 of which :	HONEYWELL	3.17 (1.440)	150.59 (3.825)
		Antenna KA 60		0.20 (0.090)	157.48 (4.000)
O	34057A	Transponder # 1 of which :	GARMIN	5.60 (2.540)	148.66 (3.776)
		Antenna KA 60		0.20 (0.090)	157.48 (4.000)
A	34058A	Transponder # 2 of which :	GARMIN	5.60 (2.540)	148.66 (3.776)
		Antenna KA 60		0.20 (0.090)	157.48 (4.000)
O	34062A	Transponder # 1 Mode S (without antenna diversity)	GARMIN	7.49 (3.400)	153.54 (3.900)
		Antenna KA 60		0.20 (0.090)	150.08 (3.812)

S/ R/ A/ O	ITEM OPT70 or MOD70	REQUIRED (R) OR STANDARD (S) OR OPTIONAL (A or O) EQUIPMENT	EQUIPMENT SUPPLIER	WEIGHT per unit lb (kg)	ARM in. (m)
O	0152-34	Transponder # 1 GTX330D Mode S (European countries only)	GARMIN	7.50 (3.400)	152.60 (3.876)
		- Without version (up to S/N 311) Antenna KA 60 (under fuselage) (above fuselage - on frame 5)	HONEYWELL	0.20 (0.090)	150.08 (3.812)
				0.20 (0.090)	176.57 (4.485)
		- Version A (from S/N 312) Antenna KA 60 (under fuselage) (above fuselage - between frames 6 and 7)		0.20 (0.090)	150.08 (3.812)
			0.20 (0.090)	193.22 (4.908)	
34-54 - Automatic Direction Finder (ADF)					
S	34055B	ADF SC+, EFIS coupled :			
		. Receiver KR 87/Indicator KI 227 P/N 066-01072-0014	HONEYWELL	3.90 (1.770)	157.48 (4.000)
		. Antenna KA 44B	HONEYWELL	2.80 (1.270)	195.28 (4.960)
		. RMI 1 KI 229 P/N 066-03038-0000 (L.H. instrument panel) (European countries only)	KING	2.87 (1.300)	153.86 (3.908)
34-55 - DME installation					
S	34014A	DME KN63 system, of which : (through NAV1 KNS81 and NAV2 KX165 channels)	HONEYWELL	4.32 (1.960)	209.84 (5.330)
		. Indicator in radio rack KDI 572	HONEYWELL	0.80 (0.363)	151.57 (3.850)
		. Receiver KN 63	HONEYWELL	2.80 (1.270)	232.28 (5.900)
		. Antenna KA 60		0.20 (0.090)	230.31 (5.850)

S/ R/ A/ O	ITEM OPT70 or MOD70	REQUIRED (R) OR STANDARD (S) OR OPTIONAL (A or O) EQUIPMENT	EQUIPMENT SUPPLIER	WEIGHT per unit lb (kg)	ARM in. (m)
A	34014C	DME KN63 system, of which : (through NAV1 KN53 and NAV2 KN53 channels)		4.32 (1.960)	209.84 (5.330)
		. Indicator in radio rack KDI 572	HONEYWELL	0.80 (0.363)	151.57 (3.850)
		. Receiver KN 63	HONEYWELL	2.80 (1.270)	232.28 (5.900)
		. Antenna KA 60		0.20 (0.090)	230.31 (5.850)
		34-57 - Global Positioning System (GPS)			
A	34033D	GPS KLN 90B (B-RNAV), EFIS coupled, of which :	HONEYWELL	8.77 (3.980)	155.20 (3.942)
		. Receiver KLN 90B	HONEYWELL	6.19 (2.810)	155.20 (3.942)
		. Antenna KA 92	HONEYWELL	0.26 (0.120)	240.16 (6.100)
		34-62 - Multifunction Display			
S	34054A	Multifunction display KMD 850	HONEYWELL	6.42 (2.910)	153.54 (3.900)
O	0210-34A	Multifunction display GMX 200	GARMIN	5.42 (2.460)	153.54 (3.900)
O	0210-34B	Multifunction display (with chart view) GMX 200	GARMIN	5.42 (2.460)	153.54 (3.900)

S/ R/ A/ O	ITEM OPT70 or MOD70	REQUIRED (R) OR STANDARD (S) OR OPTIONAL (A or O) EQUIPMENT	EQUIPMENT SUPPLIER	WEIGHT per unit lb (kg)	ARM in. (m)
		35 - OXYGEN			
S	35001B	Gaseous oxygen system	EROS/INTER TECHNIQUE	24.69 (11.200)	178.19 (4.526)

S/ R/ A/ O	ITEM OPT70 or MOD70	REQUIRED (R) OR STANDARD (S) OR OPTIONAL (A or O) EQUIPMENT	EQUIPMENT SUPPLIER	WEIGHT per unit lb (kg)	ARM in. (m)
		52 - DOORS			
A	52002A	"Pilot" door	SOCATA	44.092 (20.000)	171.26 (4.350)
A	0342-52	Additional landing gear doors	SOCATA	6.613 (3.000)	204.33 (5.190)

S/ R/ A/ O	ITEM OPT70 or MOD70	REQUIRED (R) OR STANDARD (S) OR OPTIONAL (A or O) EQUIPMENT	EQUIPMENT SUPPLIER	WEIGHT per unit lb (kg)	ARM in. (m)
S	57001A	57 - WINGS Utilization on runways covered with melting snow	SOCATA	Δ-7.716 (Δ-3.500)	200.00 (5.080)

S/ R/ A/ O	ITEM OPT70 or MOD70	REQUIRED (R) OR STANDARD (S) OR OPTIONAL (A or O) EQUIPMENT	EQUIPMENT SUPPLIER	WEIGHT per unit lb (kg)	ARM in. (m)
		61 - PROPELLER			
		61-10 - Propeller assembly			
S		Propeller (4-blade) HC-E4N.3 / E 9083 S (K)	HARTZELL	153.22 (69.500)	43.11 (1.095)
		61-20 - Controls			
R		Overspeed governor A210632	WOODWARD	2.73 (1.240)	59.06 (1.500)
S		Propeller governor 8210.007	WOODWARD	2.65 (1.200)	59.06 (1.500)

S/ R/ A/ O	ITEM OPT70 or MOD70	REQUIRED (R) OR STANDARD (S) OR OPTIONAL (A or O) EQUIPMENT	EQUIPMENT SUPPLIER	WEIGHT per unit lb (kg)	ARM in. (m)
		71 - POWER PLANT			
R		Turboprop engine PT6 A-64	P & W CANADA	496.30 (225.000)	79.72 (2.025)
S		Silentblocks (Qty 4) 95007-16	BARRY	2.92 (1.325)	79.72 (2.025)
		71-60 - Air inlet			
R		Inertia ice separator actuator 148600-09A	LPMI	1.72 (0.780)	62.99 (1.600)

S/ R/ A/ O	ITEM OPT70 or MOD70	REQUIRED (R) OR STANDARD (S) OR OPTIONAL (A or O) EQUIPMENT	EQUIPMENT SUPPLIER	WEIGHT per unit lb (kg)	ARM in. (m)
		77 - ENGINE INDICATING			
R		Compressor turbine tacho-generator (Ng) MIL-G-26611C GEU-7/A	QPL (AIRCRAFT APPLIANCES AND EQUI. LTD)	0.981 (0.445)	108.27 (2.750)
R		Gas generator speed indicator (Ng) 5428-703-91-03	SEXTANT	1.290 (0.585)	151.57 (3.850)
R		Propeller speed indicator 5428-704-91-03	SEXTANT	1.290 (0.585)	151.57 (3.850)
R		Propeller tacho-generator (Np) P/N 32005-007 MIL-G-26611 GEU-7/A	QPL (AIRCRAFT APPLIANCES AND EQUI. LTD)	0.981 (0.445)	55.12 (1.400)
R		Torquemeter 5428-750-91-03	SEXTANT	1.257 (0.570)	151.57 (3.850)
R		Torque transducer 8107.200.00.10	MORS/SEXTANT	0.463 (0.210)	53.54 (1.360)
		77-20 - Engine temperature indicating			
R		ITT indicator 5428-554-91-03	SEXTANT	1.389 (0.630)	151.57 (3.850)
		77-40 - Engine Trend Monitor (ETM)			
S	77003B	ETM (Engine Trend Monitor)	SHADIN	4.03 (1.830)	154.92 (3.935)

S/ R/ A/ O	ITEM OPT70 or MOD70	REQUIRED (R) OR STANDARD (S) OR OPTIONAL (A or O) EQUIPMENT	EQUIPMENT SUPPLIER	WEIGHT per unit lb (kg)	ARM in. (m)
		79 - LUBRICATION			
		79-20 - Distribution			
R		Oil cooler L8538233	LORI	10.472 (4.750)	90.55 (2.300)
		79-30 - Indicating			
O		Oil dual indicator 5427-350-91-03	SEXTANT	1.179 (0.535)	151.57 (3.850)
R	79001A	Oil pressure transmitter 8107-400-00-10	THALES	0.441 (0.200)	106.30 (2.700)
A	0169-79A	Chip detection system (2 detectors)	P & W CANADA	Neglig.	/
A	0169-79B	Chip detection system (1 detector)	P & W CANADA	Neglig.	/

SECTION 7

DESCRIPTION

TABLE OF CONTENTS

	Page
7.1 GENERAL	7.1.1
7.2 AIRFRAME	7.2.1
WINGS	7.2.3
AILERONS, SPOILERS AND PITCH TRIM TAB	7.2.3
WING FLAPS	7.2.3
EMPENNAGES	7.2.7
7.3 ACCOMMODATIONS	7.3.1
INSTRUMENT PANEL	7.3.1
DOORS, WINDOWS AND EMERGENCY EXIT	7.3.22
SEATS, BELTS AND HARNESSSES	7.3.30
BAGGAGE COMPARTMENTS	7.3.31
7.4 FLIGHT CONTROLS	7.4.1
ROLL	7.4.1
ROLL TRIM	7.4.1
ELEVATOR	7.4.7
PITCH TRIM	7.4.7
RUDDER	7.4.13
RUDDER TRIM	7.4.13
7.5 LANDING GEAR	7.5.1
HYDRAULIC PRESSURE	7.5.2
LANDING GEAR CONTROL	7.5.2
LANDING GEAR INDICATOR	7.5.2
SAFETY	7.5.4
GROUND MANEUVERS	7.5.6
BRAKE SYSTEM	7.5.9
PARKING BRAKE	7.5.9

TABLE OF CONTENTS
(Continued)

		Page
■	7.6 POWERPLANT	7.6.1
	TURBOPROP ENGINE OPERATION	7.6.1
	ENGINE CONTROLS (LEVERS)	7.6.4
	ENGINE INSTRUMENTS	7.6.7
	ENGINE LUBRICATION	7.6.12
	ENGINE STARTING	7.6.12
	ENGINE AIR INLET	7.6.14
	EXHAUST SYSTEM	7.6.15
	ENGINE ACCESSORIES	7.6.15
	PROPELLER	7.6.17
7.7	FUEL SYSTEM	7.7.1
	FUEL TANKS	7.7.1
	FUEL UNIT	7.7.1
	TANK MANUAL SELECTOR	7.7.1
■	AUTOMATIC TANK SELECTOR	7.7.4
	ELECTRIC BOOST PUMP	7.7.5
	MAIN MECHANICAL BOOST PUMP	7.7.8
	ENGINE FUEL SYSTEM	7.7.8
	FUEL GAGING INSTALLATION	7.7.8
	ETM INDICATOR/COMPUTER	7.7.8
	FUEL MONITORING INSTALLATION	7.7.9
	FUEL SYSTEM DRAINING AND CLOGGING INDICATOR	7.7.10
7.8	ELECTRICAL SYSTEM	7.8.1
	STARTER GENERATOR	7.8.1
	STAND-BY GENERATOR	7.8.2
	BATTERY	7.8.2
	GROUND POWER RECEPTACLE	7.8.2
	DISTRIBUTION	7.8.4
	EMERGENCY USE	7.8.4
	INDICATING	7.8.15
	PROTECTION - SAFETY	7.8.16
	EXTERIOR LIGHTING	7.8.20
	INTERIOR LIGHTING	7.8.24

TABLE OF CONTENTS

(Continued)

	Page
7.9 AIR CONDITIONING AND PRESSURIZATION	7.9.1
AIR CONDITIONING	7.9.1
PRESSURIZATION	7.9.9
7.10 EMERGENCY OXYGEN SYSTEM	7.10.1
FLIGHT ABOVE 15000 FT WITH EMERGENCY DESCENT	7.10.4
WHEN REQUIRED TO REMAIN ABOVE 15000 FT DUE TO MINIMUM "EN ROUTE" ALTITUDE	7.10.5
FLIGHT BETWEEN 15000 FT AND 10000 FT	7.10.6
7.11 AIR DATA SYSTEM AND INSTRUMENTS	7.11.1
STATIC PRESSURE SYSTEMS	7.11.1
DYNAMIC PRESSURE SYSTEM	7.11.4
7.12 VACUUM SYSTEM AND INSTRUMENTS	7.12.1
ATTITUDE INDICATOR	7.12.1
GYROSCOPIC INSTRUMENTS CONTROL	7.12.5
SUCTION GAGE	7.12.5
7.13 ICE PROTECTION EQUIPMENT	7.13.1
WING AND EMPENNAGE DEICING	7.13.1
PROPELLER DEICING	7.13.2
WINDSHIELD DEICING	7.13.2
HEATING OF PITOTS AND STALL WARNING SENSOR	7.13.3
TURBINE AIR INLET PROTECTION	7.13.3
7.14 RADIO MASTER AND GROUND COMMUNICATION	7.14.1
7.15 MISCELLANEOUS EQUIPMENT	7.15.1
STALL WARNING SYSTEM	7.15.1
STATIC DISCHARGERS	7.15.1
CABIN FIRE EXTINGUISHER	7.15.2
AUTOPILOT	7.15.2
EMERGENCY LOCATOR TRANSMITTER	7.15.2

INTENTIONALLY LEFT BLANK

7.1 - GENERAL

This Section provides description and operation of the TBM 700 airplane and its systems. Some of the equipment described herein is optional and may not be installed in the airplane.

Details of other optional systems and equipment are presented in Section 9 "Supplements" of the pilot's operating handbook.

NOTE :

Description and operation of communication and radio-navigation equipment are detailed in manufacturer technical handbooks.

INTENTIONALLY LEFT BLANK

7.2 - AIRFRAME

The TBM 700 is a six-place, low wing airplane. The structure is a semi-monocoque all-metal construction and is equipped with a retractable tricycle landing gear.

The pressurized cabin is equipped, on the left side of fuselage, with a "wide" one-piece door and folding stairs comprising a hand rail allowing pilot and passengers boarding. The occupants have access to cockpit and to rear seats through a central aisle.

A "pilot" door (if installed) located forward of the cabin on the left side allows to gain access to the cockpit by means of folding stairs.

The cabin rear part is a baggage compartment.

In fuselage non pressurized rear section, a compartment located between the rear pressure bulkhead at frame C17 and the frame C18 is provided as a secondary baggage compartment ; it is accessible through a door located on the fuselage L.H. side.

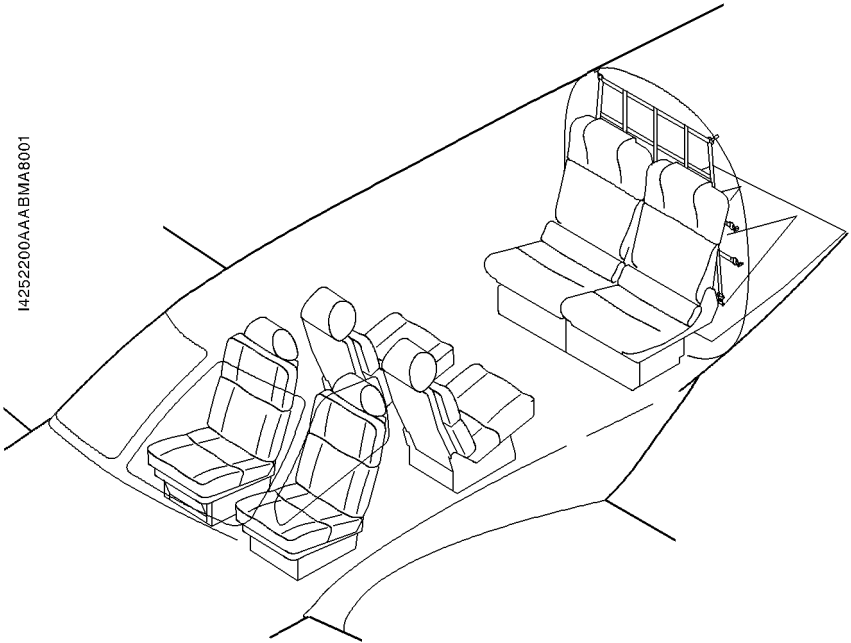

Figure 7.2.1 - CABIN ARRANGEMENT

WINGS

The wings are monocoque, bi-spar structures. Main spars of each wing are linked to the fuselage by two integral attach fittings. Each wing contains a main landing gear well and sealed casings forming the fuel tank. The wing leading edge is equipped with a deicing system.

AILERONS, SPOILERS AND PITCH TRIM TAB

The ailerons located on external trailing edge of each wing are hinged on two attach fittings fixed on the rear spar. They allow airplane lateral control and are controlled mechanically through control wheel rotation.

The spoilers located in front of flaps, on top skin side, are mechanically linked to the ailerons.

Trim tab knob attached on the trailing edge of L.H. aileron is electrically activated by a trim knob, through an actuator.

WING FLAPS (Figure 7.2.2)

The wing flaps are large span slotted flaps with a single rotation point. They are activated by actuating rod-controlled screw jacks linked to an electric motor located under the floor, inside the fuselage.

A preselection control located on the right side of pedestal console allows the pilot to select one of the three positions (UP - TO - LDG). For each control position, a deflection angle is defined (0°, 10°, 34°).

The flap control knob is protected by a casing to avoid accidental operation.

A monitoring device interrupts flaps movement as soon as a deflection dissymmetry is detected.

Wings characteristics :

Area	193.75 sq. ft (18 m ²)
Wing loading	34 lb/sq.ft (165.8 kg / m ²)
Root chord at y = 2.13 ft (0.650 m)	5.79 ft (1.765 m)
Tip chord	3.67 ft (1.120 m)
Mean aerodynamic chord at y = 9.16 ft (2.793 m)	4.95 ft (1.510 m)
Rigging angle to fuselage horizontal datum	2°
Sweep-angle (at 25 % chord)	0°
Dihedral (at datum plane)	6.5°
Aspect ratio (platform reference)	8.216
Taper ratio	0.608
Airfoil section (at wing root)	RA 16-43
Airfoil section (at wing tip)	RA 13.3-43
Twist	0°

Aileron - spoilers characteristics :

Global aileron area (including trim tab)	9.65 sq.ft (0.897 m ²)
Aileron trim tab area	0.78 sq.ft (0.072 m ²)
Spoiler area	1.80 sq.ft (0.167 m ²)

Flaps characteristics :

Type	Single-slotted, rotational
Global flap area	40.68 sq.ft (3.780 m ²)

- 1) Geared motor
- 2) Internal actuator
- 3) Intermediate bearings
- 4) Wing flap
- 5) External actuator
- 6) Rods
- 7) Position indicator
- 8) Control selector

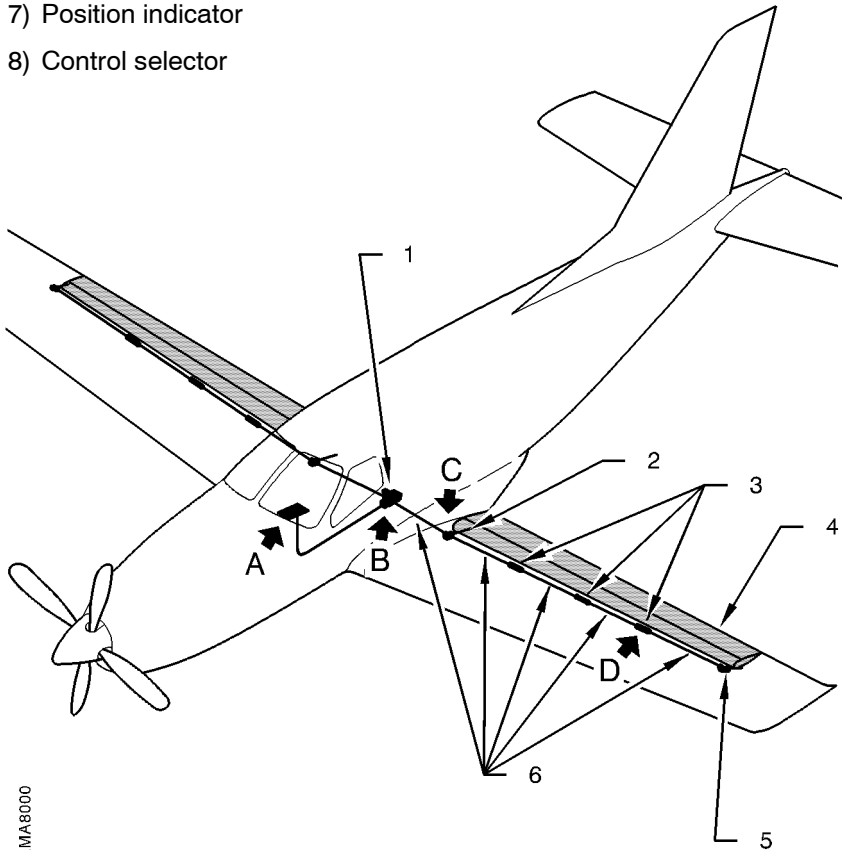

I4275000AAAAA8000

Figure 7.2.2 (1/2) - WING FLAPS

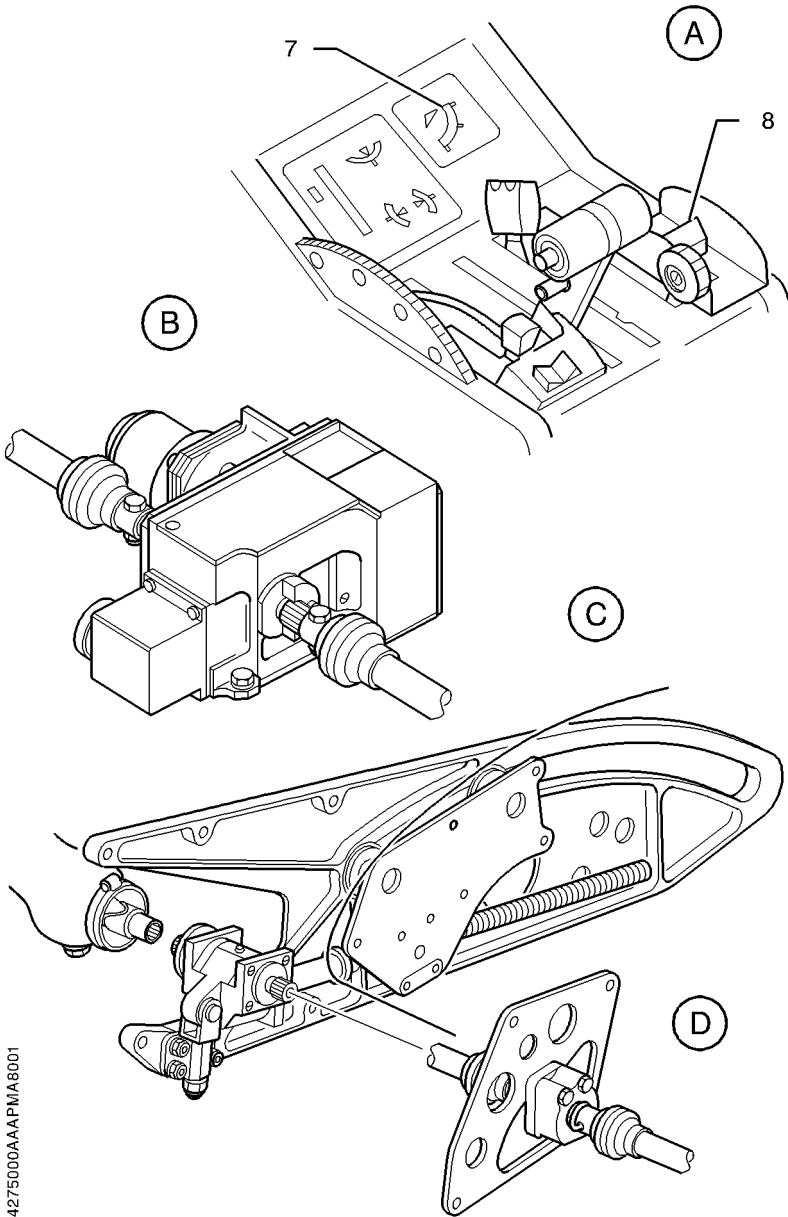

14275000AAAAP/A8001

Figure 7.2.2 (2/2) - WING FLAPS

EMPENNAGES

Empennages are composite structures. The horizontal empennage consists of a horizontal stabilizer (PHF), control surfaces and elevator trim tabs ; the vertical empennage consists of a vertical stabilizer, the rudder and the rudder trim tab. The empennage leading edge is equipped with a deicing system.

Horizontal stabilizer characteristics :

Overall span	16.36 ft (4.988 m)
Global area	52.52 sq.ft (4.879 m ²)
Chord	3.89 ft (1.186 m)
Tip chord	2.60 ft (0.795 m)
Mean aerodynamic chord at y = 3.76 ft (1.147 m)	3.26 ft (0.995 m)
Airfoil section	NACA 64 ₂ -A415 modified
Dihedral	6.5°
Rigging angle (leading edge up)	0.5°
Aspect ratio	5.034
Elevator global area (including trim tabs)	21.76 sq.ft (2.022 m ²)
Elevator trim tab area (right datum plane)	3.47 sq.ft (0.322 m ²)

Vertical stabilizer characteristics :

Global area	33.28 sq.ft (3.092 m ²)
Construction root chord	6.95 ft (2.120 m)
Reference tip chord	2.54 ft (0.775 m)
Mean aerodynamic chord	5.08 ft (1.551 m)
Construction airfoil section	NACA 63 ₁ -A012 modified
Sweep angle (at leading edge)	45°
Aspect ratio	1.481
Rudder area (including trim tab)	11.87 sq.ft (1.103 m ²)
Rudder trim tab area	1.36 sq.ft (0.126 m ²)

INTENTIONALLY LEFT BLANK

7.3 - ACCOMODATIONS

INSTRUMENT PANEL (Figure 7.3.1)

The instrument panel contains instruments and controls necessary for flight monitoring. The typical instrument panel consists of all standard equipment, as well as additional optional equipment.

Upper panel (Figure 7.3.2)

The upper panel located at the top part of the windshield, contains electrical generation control panels, engine starting and ancillary electrical systems.

Rearwards of upper panel, the central part of cockpit overhead panel provides loud-speakers, warning buzzers and cockpit floodlights and postlights (instrument panel emergency lighting).

Instrument panel

The instrument panel consists of three parts : left, central and right.

Left instrument panel (Figure 7.3.3) includes :

- general alarms, flight indicators and instruments, engine controls, deicing controls and indicators, landing gear control panel, parking brake control and left station control wheel.

Central instrument panel (Figure 7.3.4), surmounted by the stand-by compass, includes :

- control and AP computer boxes, advisory panel box, the radionavigation equipment box, "AP / TRIMS MASTER", "RADIO MASTER" and internal lighting switches.

Right instrument panel (Figure 7.3.5) comprises :

- "FUEL" and "ECS" control and check panels, flight indicators and instruments, the right section control wheel, alternate static source selector and locations for optional equipment.
- Emergency air control is located under the right instrument panel.

An adjustable air outlet and reception-micro jacks are located on both sides of instrument panel lower part.

Central pedestal (Figure 7.3.6)

The central pedestal under the radio rack, comprises position indicators and trim tabs controls, flaps, engine controls and fuel tank selector.

Circuit breakers panel (Figures 7.3.7 and 7.8.2)

Circuit breakers for all electrical equipment supplied by bus bars are located on a separate panel installed on the left side of cockpit, near the pilot or on right side when the airplane is equipped with a "pilot" door.

Advisory panel (Figure 7.3.8)

The advisory panel is attached on the upper central part of the instrument panel. This panel provides warning lights which alert the pilot when one of the monitored systems indicates a discrepancy.

A "MASTER WARNING" red flashing indicator and a "MASTER CAUTION" amber flashing indicator located on instrument panel in front of the pilot, illuminate as soon as one or several indicators of same color illuminate on the advisory panel.

To cancel and reset a general alarm, press on the red or amber indicator.

A "TEST" push-button and a "BRIGHT DIM" switch, located on the right side of the advisory panel, allows testing warning lights (double check) and dimming of their lighting (day / night position).

Aural warnings (Figure 7.3.2)

The aural warnings are intended to alert the pilot during some configurations. The aural signals are heard through the loud-speakers or the buzzers installed in upper panel, and for the KRA 405 radar altimeter through the buzzer located on the R.H. instrument panel. Aural warnings concerning the landing gear and the autopilot are also heard in the head-sets.

The aural warnings consist of :

- the aural warning box,
- the buzzers and loud-speakers,
- the amplifier.

The system uses :

- the stall warning horn,
- the VMO alarm,
- AP alarms,
- the landing gear control unit,
- the flap geared motor,
- the radar altimeter aural warning.

Aural warning box

The aural warning box consists of a box including logic circuits, which create the signals heard in the aural warning loud-speaker.

According to the airplane configuration, different signals are produced by the logic circuits :

- gear up and idle → high-pitched sound
- gear up and extended flaps → high-pitched sound
- stall → low-pitched sound
- gear up, idle and stall → alternate high-pitched and low-pitched sounds
- gear up, extended flaps and stall → alternate high-pitched and low-pitched sounds

The aural warning box is fixed under cabin floor, on L.H. side, between frames C5 and C6.

It is electrically supplied by "ESS BUS 1" bar and protected by "AUDIO WARN" circuit breaker.

Upper panel (Figure 7.3.2)

The upper panel includes following elements :

- the alarm loud-speaker (landing gear up with flaps extended and / or idle, stall),
- the altitude preselection indicating buzzer,
- the autopilot disconnection indicating buzzer,
- the VMO alarm buzzer,
- the "HORN TEST" knob,
- the emergency lighting rheostat.

It is attached to the cabin upper part between frames C6 and C7.

The alarm loud-speaker is electrically supplied by the aural warning box, the VMO alarm buzzer is electrically supplied by "ESS BUS 1" bar and protected by "AUDIO WARN" circuit breaker, the altitude preselection indicating buzzer is protected by "AP / ALT SEL" circuit breaker, the autopilot disconnection indicating buzzer is electrically supplied by "BUS 3" bar and protected by "AP / ALERT" circuit breaker and the emergency lighting rheostat is electrically supplied by "BUS BAT" bar and protected by "PANEL EMER" circuit breaker.

Amplifier

The amplifier allows to fit alarm signals heard in head-set to radio loud-speaker.

It is fixed under cabin floor, on L.H. side, between frames C6 and C7.

It is electrically supplied by "ESS BUS 1" bar and protected by "PHONE+MKR" circuit breaker.

Aural warning operation

The alarm loud-speaker receives signals from the aural warning box. According to the airplane configuration, these signals are low-pitched and / or high-pitched. Buzzers receive their signal directly from the concerned circuit.

All warning signals go through the amplifier before being heard in head-sets and in the radio loud-speaker.

The "HORN TEST" knob allows to test the correct operation of aural warnings :

- Set the "SOURCE" selector to "BAT" or to "GPU".
- Push and hold the "HORN TEST" knob :
 - . the VMO buzzer emits three "bips",
 - . the alarm loud-speaker emits alternate low-pitched and high-pitched sounds.
- Release the knob to stop the alarms.

NOTE :

The test is effective for head equipment when "AP / TRIMS MASTER" switch is set to "ON".

Operation of the radar altimeter aural warning

The radar altimeter aural warning (momentary) is coupled with the "DH" warning light (permanent illumination) on the radar altimeter indicator or the EADI.

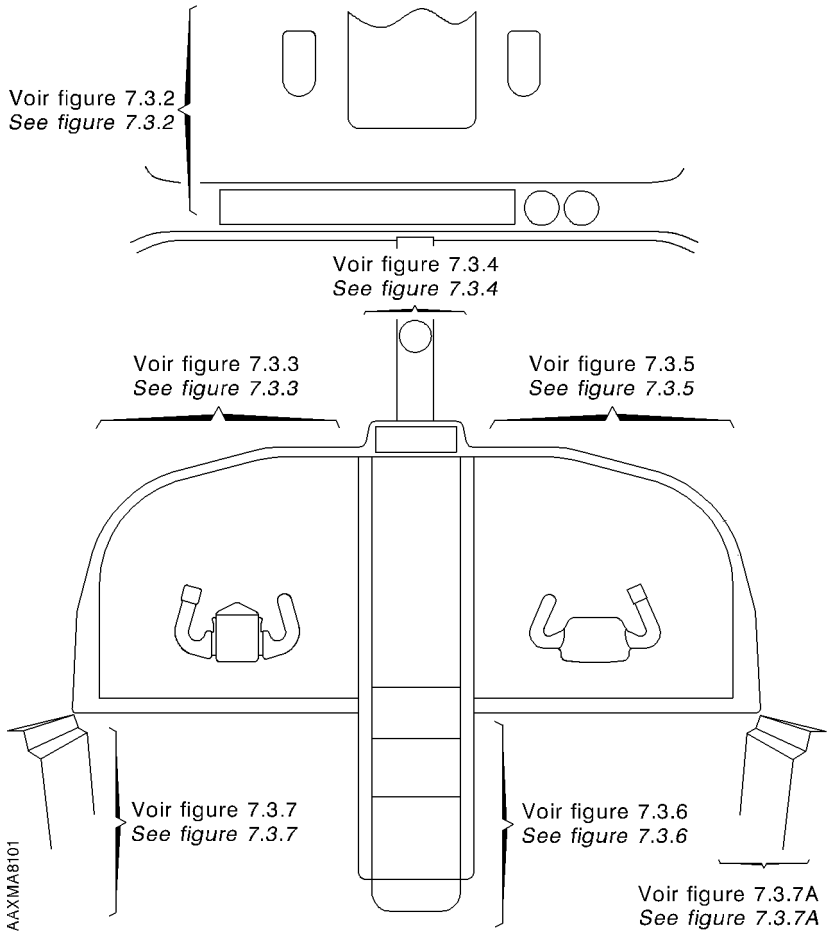
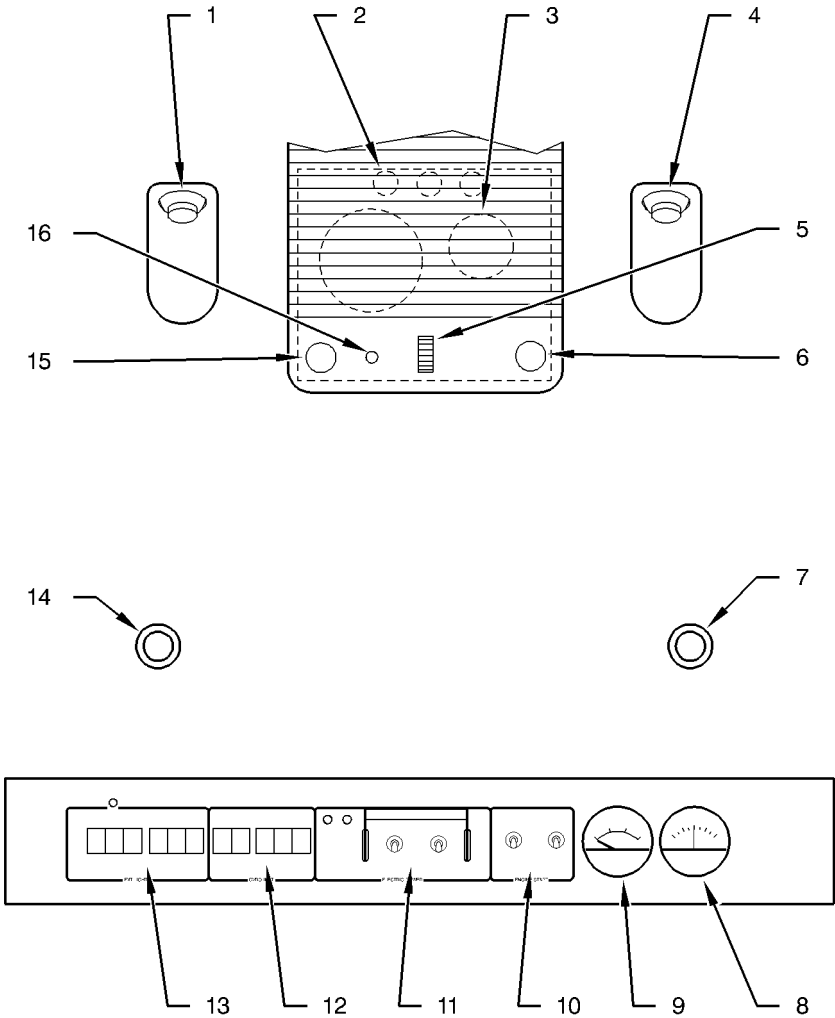

Figure 7.3.1 - INSTRUMENT PANEL ASSEMBLY
(Typical arrangement)

INTENTIONALLY LEFT BLANK

- 1) L.H. instrument panel emergency lighting
- 2) Buzzers (AP, landing gear not extended and V_{MO} alarms)
- 3) Loud-speakers (radio and stall warning horn)
- 4) R.H. instrument panel emergency lighting
- 5) Cockpit floodlight switches (rheostats)
- 6) R. H. side upper panel postlight
- 7) R.H. cockpit floodlight
- 8) Ammeter
- 9) Voltmeter
- 10) "ENGINE START" switches (Figure 7.6.5)
- 11) "ELECTRIC POWER" switches (Figure 7.8.5)
- 12) "GYRO INST" gyroscopic instrument switches (Figure 7.12.2)
- 13) "EXT LIGHTS" external lighting switches (Figure 7.8.6)
- 14) L.H. cockpit floodlight
- 15) L. H. side upper panel postlight
- 16) "HORN TEST" aural warning test

Figure 7.3.2 (1/2) - UPPER PANEL AND COCKPIT OVERHEAD PANEL



14251600AAANMA8200

Figure 7.3.2 (2/2) - UPPER PANEL AND COCKPIT OVERHEAD PANEL

- | | |
|---|---|
| 1) Altitude preselection indicator | 22) "AP / DISC TRM INT" red push-button |
| 2) GPS indicator lights | 23) Electric pitch trim control |
| 3) Encoding altimeter 1 | 24) Maps reading tablet |
| 4) Torquemeter | 25) Electric rudder trim control |
| 5) Propeller RPM indicator | 26) Left station reception-micro jacks |
| 6) "PROP O'SPEED TEST" knob | 27) L.H. station rudder pedals adjusting handle |
| 7) Vertical speed indicator 1 | 28) Adjustable air outlet |
| 8) ITT indicator | 28a) L.H. cockpit floodlight switch |
| 9) ITT test knob | 29) Flight conditions and instruction placard |
| 10) Gas generator speed indicator (Ng) | 30) "DE ICE SYSTEM" panel postlight |
| 11) EGPWS control box | 31) OAT indicator |
| 12) Oil pressure and temperature indicator | 32) Chronometer |
| 13) ETM indicator/computer | 33) Stand-by horizon |
| 14) Landing gear configuration and control panel (Figure 7.5.1) | 34) VOR / ILS 2 indicator |
| 15) Oxygen mask microphone switch (Figure 7.10.1) | 35) "GYRO 1 mode" indicator |
| 16) Left station control wheel tube | 36) Suction indicator |
| 17) Parking brake control | 37) Airspeed indicator 1 |
| 18) EHSI indicator | 38) General alarm red and amber indicators |
| 19) RMI indicator | 39) EADI indicator |
| 20) Deicing control and check panel (Figure 7.13.1) | 40) EFIS control panel |
| 21) Circuit breakers panel postlight (without "pilot" door) | |

Figure 7.3.3 (1/2) - LEFT INSTRUMENT PANEL

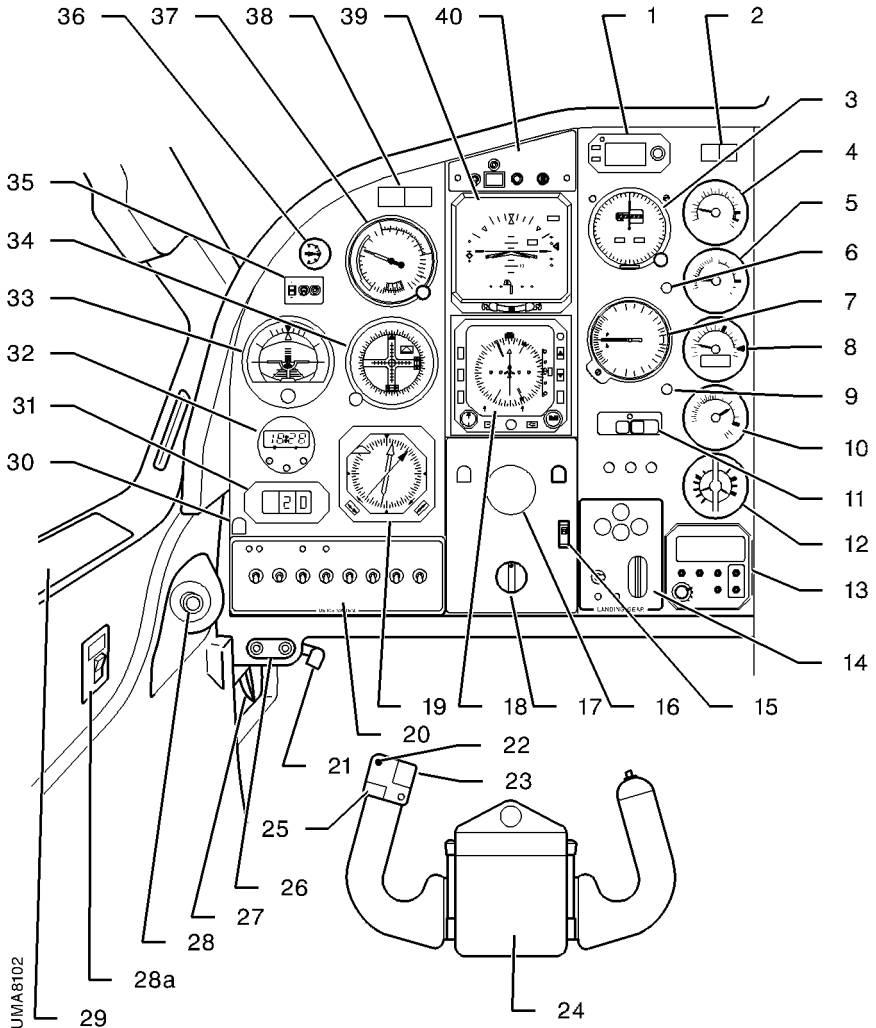
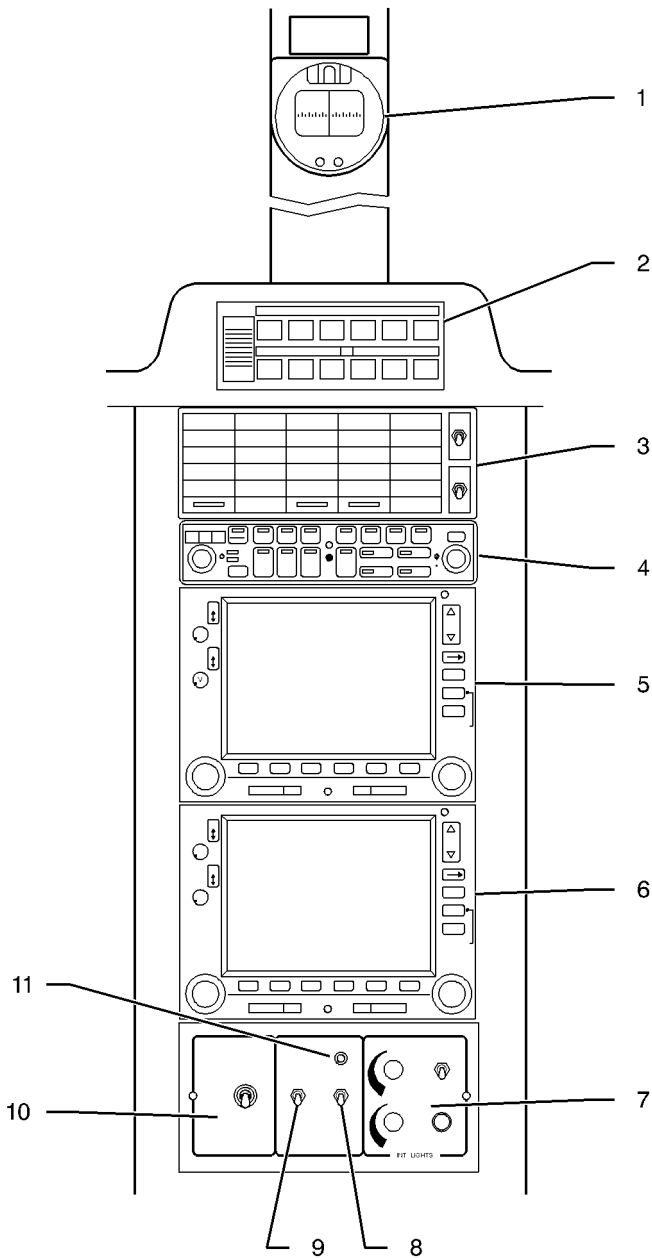

Figure 7.3.3 (2/2) - LEFT INSTRUMENT PANEL
(Typical arrangement)

14251000AAUJMA8102

- 1) Stand-by compass
- 2) AP mode controller (see Section 9)
- 3) Advisory panel (Figure 7.3.8)
- 4) Audio control box
- 5) COM/NAV/GPS 1
- 6) COM/NAV/GPS 2
- 7) Cabin interior lighting rheostats and switches (Figure 7.8.7)
- 8) "RADIO MASTER" switch (Figure 7.14.1)
- 9) "EFIS MASTER" switch (see Section 9)
- 10) "AP / TRIMS MASTER" switch (see Section 9)
- 11) "GND CLR" ground communication indicating light (Figure 7.14.1)

Figure 7.3.4 (1/2) - CENTRAL INSTRUMENT PANEL



I4251000AAA YMA8201

Figure 7.3.4 (2/2) - CENTRAL INSTRUMENT PANEL
(Typical arrangement)

- 1) "FUEL" check and control panel (fuel pressure and quantity indicators, "FUEL SEL" and "AUX BP" switches) (Figure 7.7.3)
- 2) ELT remote control switch
- 3) "GYRO 2 mode" indicator
- 4) Airspeed indicator 2
- 5) ADI 2 indicator
- 6) Encoding altimeter 2
- 7) HSI 2 indicator
- 8) Vertical speed indicator 2
- 9) Transponder 2
- 10) DME
- 11) Hour meter
- 12) Adjustable air outlet
- 13) R. H. station rudder pedals adjusting handle
- 14) Right station reception-micro jacks
- 15) Circuit breakers panel postlight (with "pilot" door)
- 16) Electric pitch trim control
- 17) Electric rudder trim control
- 18) "AP / DISC TRM INT" red push-button
- 19) Maps reading tablet
- 20) Radar altimeter buzzer
- 21) Cabin emergency air control ("RAM AIR" control knob)
- 22) Static source selector
- 23) Right station control wheel tube
- 24) "ECS" air conditioning and pressurization panel (Figure 7.9.3)
- 25) Radar altimeter indicator
- 26) Transponder 1
- 27) ADF
- 28) MFD

Figure 7.3.5 (1/2) - RIGHT INSTRUMENT PANEL

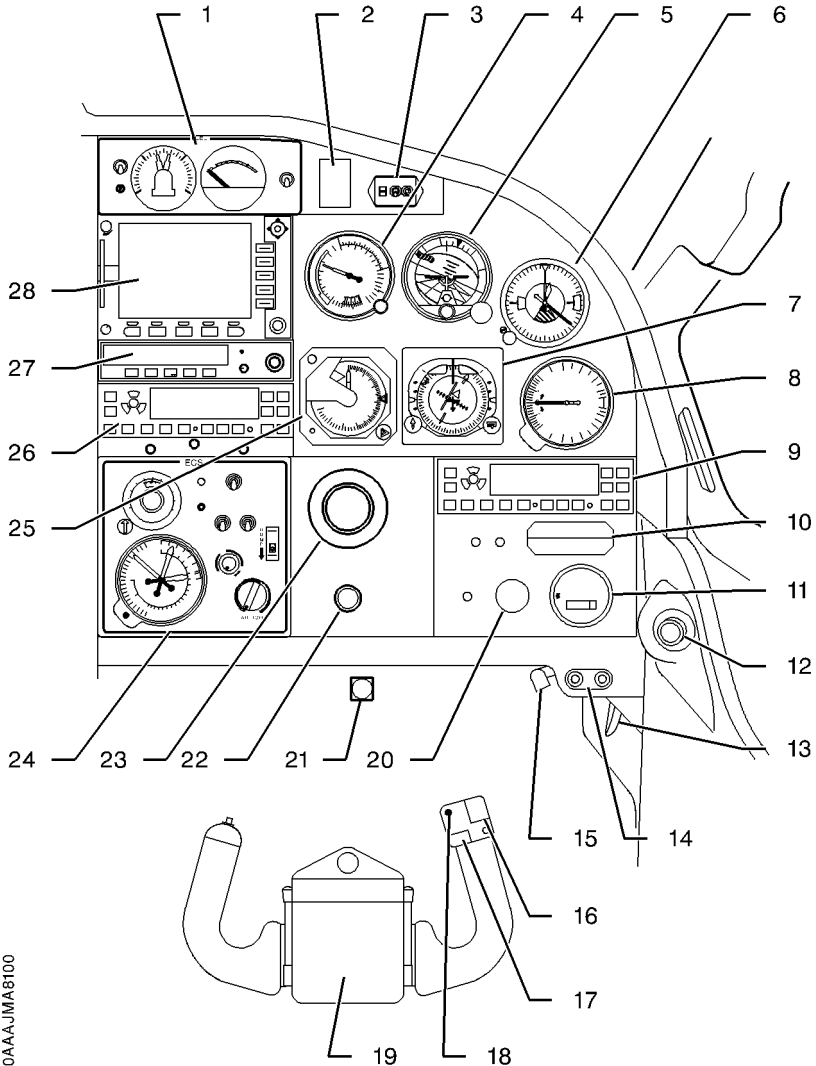

14251000AAA-JMA8100

Figure 7.3.5 (2/2) - RIGHT INSTRUMENT PANEL
(Typical arrangement)

- 1) Trim tabs indicators
- 2) Flaps position indicator
- 3) Propeller governor lever
- 4) Power lever
- 5) Flaps control
- 6) Condition lever
- 7) Levers friction adjustment
- 8) Emergency fuel control
- 9) Manual fuel tank selector (Figure 7.7.2)
- 10) Roll trim tab control
- 11) Pitch trim tab control
- 12) Lock for access door to landing gear emergency pump (Figure 7.5.2)

Figure 7.3.6 (1/2) - PEDESTAL CONSOLE

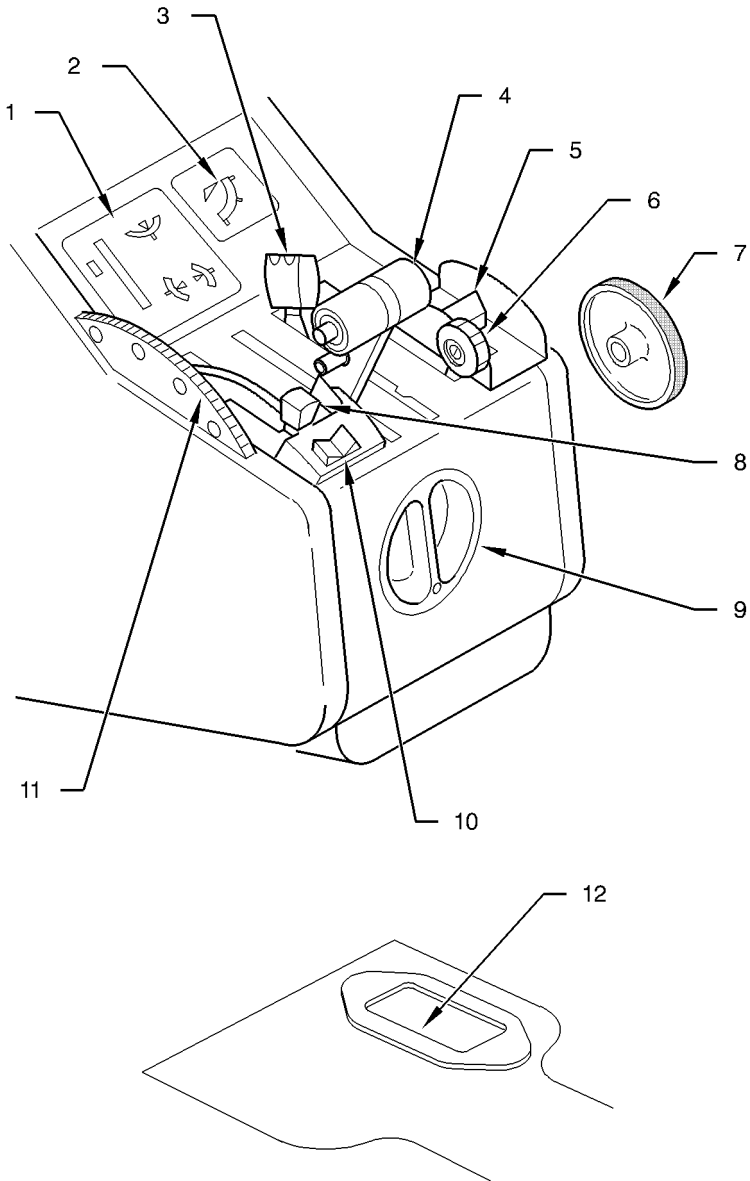

14251400AAAABMA8000

Figure 7.3.6 (2/2) - PEDESTAL CONSOLE
(Typical arrangement)

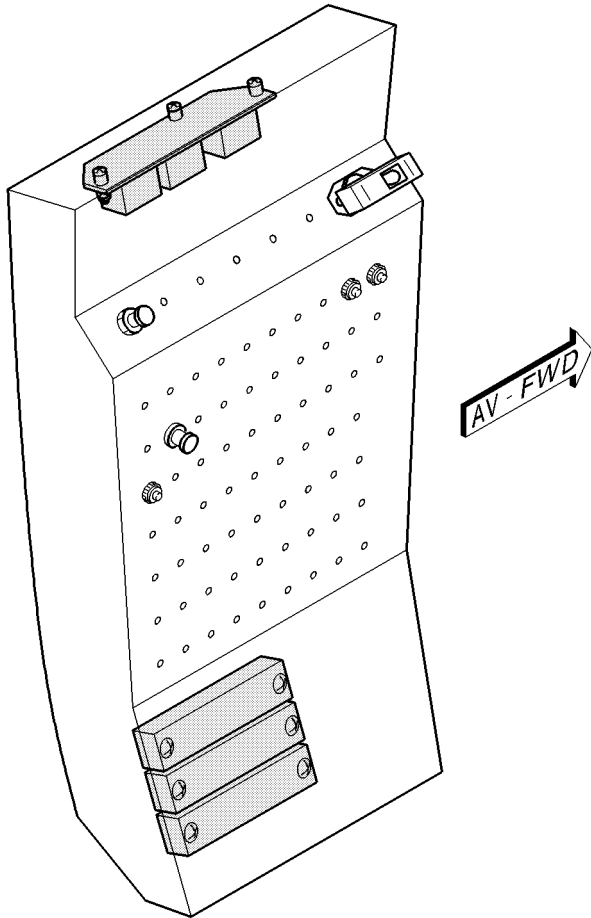
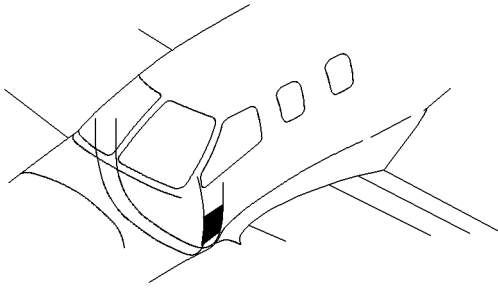

14246001AAAAA8001

Figure 7.3.7 - CIRCUIT BREAKERS PANEL - Without "pilot" door

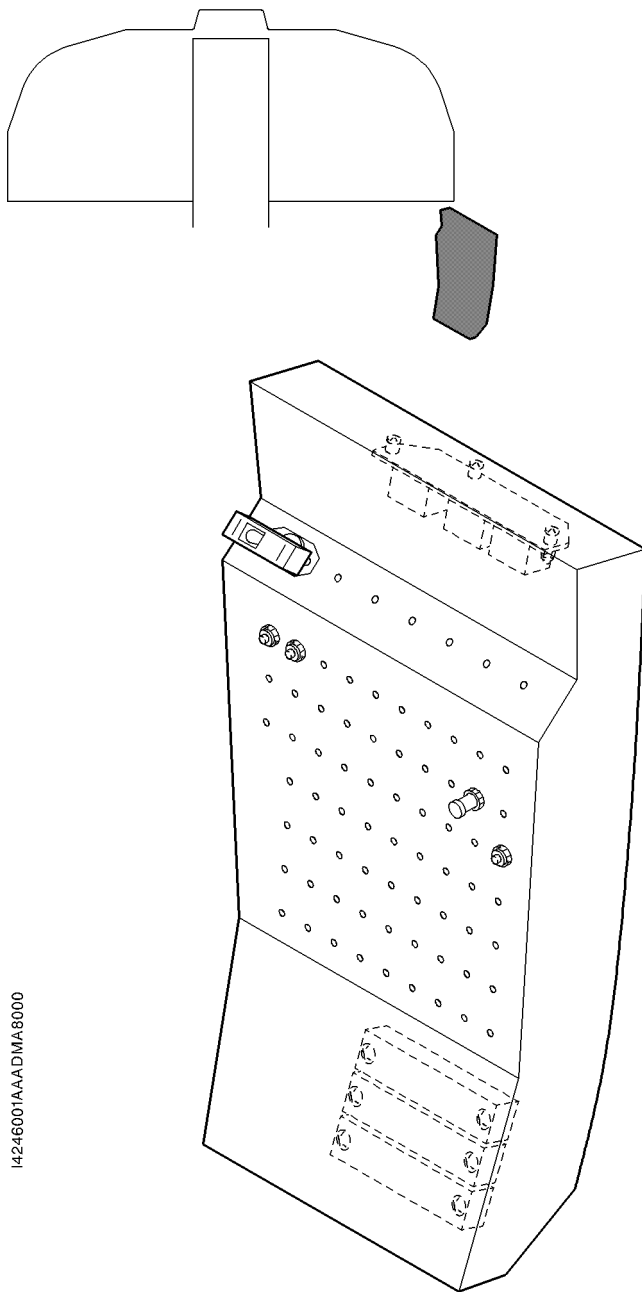

14246001AAADMA8000

Figure 7.3.7A - CIRCUIT BREAKERS PANEL - With "pilot" door

MASTER WARNING	General warning upon illumination of red warning light
MASTER CAUTION	General warning upon illumination of amber warning light
ITT	Inter turbine temperature $\geq 800^{\circ}\text{C}$
OIL PRESS	Engine oil low pressure ≤ 4.1 bar (60 psi)
STARTER	Starter generator running (flashing)
IGNITION	Ignition exciter running
PARK BRAKE	Parking brake applied
FIRE	Engine compartment fire (temperature greater than 200°C) (if installed)
BLEED TEMP	Conditioned air temperature at outlet cooling turbine compressor $\geq 317^{\circ}\text{C}$
BLEED OFF	Pressure regulator / shut-off closed
CAB PRESS	Cabin altitude ≥ 10000 ft or $\Delta P \geq 423$ mbar (6.2 psi)
DOOR	Passenger's door, not closed and locked
FLAPS	Dissymmetry between L.H. and R.H. flaps
OXYGEN	Oxygen cylinder closed
PITOT 1	Pitot tube Nr 1 not heated
PITOT 2	Pitot tube Nr 2 not heated
STALL HTR	Stall warning not heated
INERT SEP	Inertial separator "INERT SEP" control switch set to "ON"
VACUUM LO	Vacuum generator, vacuum ≤ 3.75 in.Hg
BAT OVHT	Battery abnormal temperature (if Cadmium-Nickel battery installed)
BAT OFF	Battery unconnected and main distribution bar supplied by another generator
MAIN GEN	Starter generator unconnected
LO VOLT	Battery, voltage ≤ 26 Volts
G P U	GPU receptacle door not closed
FUEL OFF	Fuel tank selectors set to "OFF"
FUEL PRESS	Fuel pressure ≤ 10 psi (± 2 psi)
AUX BP ON	Electric fuel pump, running (manual or automatic mode)
FUEL L. LO	L.H. fuel tank low level, fuel quantity ≤ 34.6 l (9.1 us gal)
FUEL R. LO	R.H. fuel tank low level, fuel quantity ≤ 34.6 l (9.1 us gal)
AUTO SEL	Fuel timer OFF or out of service
BRIGHT	Indicator lights brightness selector, day position
DIM	Indicator lights brightness selector, night position
TEST 1 & 2	Lights test switch (double check)

Figure 7.3.8 (1/2) - ADVISORY PANEL AND GENERAL ALARMS WARNING LIGHTS

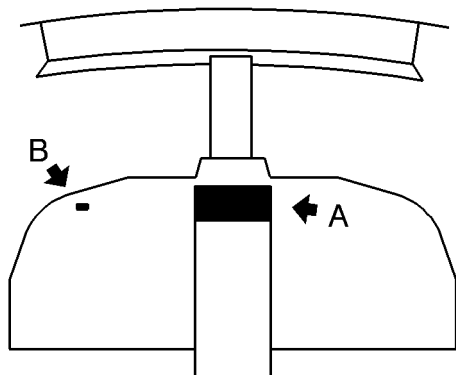

(A)

ITT	BLEED TEMP	PITOT 1	BAT OVHT	FUEL OFF	BRIGHT
OIL PRESS	BLEED OFF	PITOT 2	BAT OFF	FUEL PRESS	DIM
STARTER	CAB PRESS	STALL HTR	MAIN GEN	AUX BP ON	TEST 1
IGNITION	DOOR	INERT SEP	LO VOLT	FUEL L.LO	TEST 2
PARK BRAKE	FLAPS	VACUUM LO	GPU	FUEL R.LO	
	OXYGEN			AUTO SEL	

(B)

Légende voyants
Lights key



Rouge
Red



Ambre
Amber

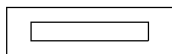

Non utilisé
Free



14315001AAABMIA8003

Figure 7.3.8 (2/2) - ADVISORY PANEL AND GENERAL ALARMS WARNING LIGHTS

DOORS, WINDOWS AND EMERGENCY EXIT

Cabin access door (Figure 7.3.9)

The cabin one-piece access door, located on the left side of fuselage aft of the wings, opens outside. The retractable stairs and hand rail make boarding easier.

To open the door from outside the airplane (make sure the door is not locked), press on front end of the handle embeded in door (this pressure disengages the handle from its recess), then turn the handle upwards. Raise the door helping it to open. Two compensation actuators bring and maintain the door at its maximum opening position.

After door opening, tilt stairs downwards. Stairs down movement is damped by means of two gas struts and leads the hand rail to extend.

CAUTION

RETRACT STAIRS BEFORE CLOSING ACCESS DOOR AND MAKE SURE DOOR DEFLECTION AREA IS CLEAR

To retract stairs, press on locking pin located on stairs front string board (see detail "1"), raise retractable handle (see detail "2") and pull stairs inside cabin. While stairs are retracted, the hand rail folds up.

To close the door from inside the airplane, press on knob inside cabin forward of the door. The door driven by a geared motor tilts downwards up to a position near the complete closing. Pull the door until it aligns with fuselage and lock it by moving inside handle downwards. Check that all latch pins and hooks are correctly engaged (visible green marks).

The "DOOR" warning light located on advisory panel remains illuminated as long as the door is not correctly locked.

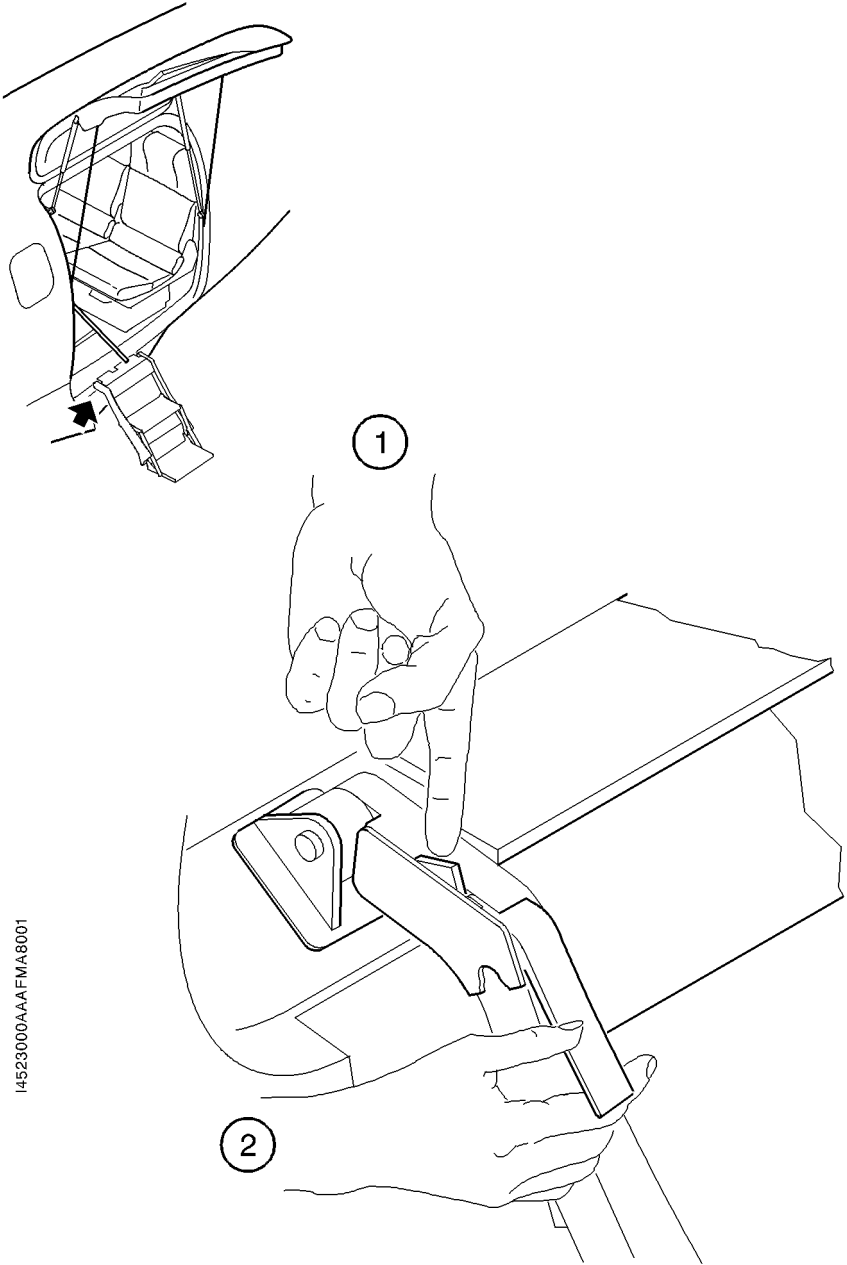

I4523000AAA FMA8001

Figure 7.3.9 - CABIN ACCESS DOOR

CAUTION

**BEFORE OPENING ACCESS DOOR, MAKE SURE DOOR
DEFLECTION AREA IS CLEAR**

To open door from inside the cabin, unlock the handle by pressing on knob located on its left side, pull the handle toward inside and move it upwards. Open the door by pushing it upwards.

After door opening, tilt stairs downwards which leads the hand rail to extend.

CAUTION

**RETRACT STAIRS BEFORE CLOSING ACCESS DOOR AND MAKE
SURE DOOR DEFLECTION AREA IS CLEAR**

To retract stairs from outside the airplane, raise stairs by pushing them upwards from the lower part and fold them inside cabin. While stairs are retracted, the hand rail folds up.

To close the door from outside the airplane, press on knob on outside fuselage at the right side of the door. The door driven by a geared motor tilts downwards up to a position near the complete closing. Push the door until it aligns with fuselage and lock it by moving outside handle downwards, then fold handle in its recess.

Check that all latch pins and hooks are correctly engaged (visible green marks).

In case of geared motor failure, the door can be manually tilted downwards by pulling sufficiently to override action of compensating struts.

Cockpit access door (Figure 7.3.9A)

The cockpit access door, so-called "pilot" door, (if installed) located on the left side of fuselage forward of the wings, opens outside. Retractable footstep makes boarding easier.

WARNING**AS THE "PILOT" DOOR IS LOCATED IN A DANGEROUS AREA, WAIT FOR COMPLETE ENGINE STOP BEFORE OPERATING THIS DOOR**

To open the door from outside the airplane (make sure the door is not locked), press on front end of the handle embedded in door (this pressure disengages the handle from its recess), then turn the handle downwards. Pull the door helping it to open until it reaches its maximum opening position.

After door opening, tilt and unfold footstep.

CAUTION**RETRACT FOOTSTEP BEFORE CLOSING ACCESS DOOR**

Fold and tilt footstep upwards.

To close the door from inside the airplane, pull the door until it aligns with fuselage and lock it by moving inside handle downwards. Check that each latch is correctly engaged in its recess (visible green marks).

The "DOOR" warning light located on advisory panel remains illuminated as long as cabin access door and / or "pilot" access door is (are) not correctly locked.

To open door from inside the cockpit, unlock the handle by pressing on knob located on its right side, pull the handle inwards and move it upwards. Open the door helping it to open until it reaches its maximum opening position.

After door opening, tilt and unfold footstep.

CAUTION**RETRACT FOOTSTEP BEFORE CLOSING ACCESS DOOR**

Fold and tilt footstep upwards.

To close the door from outside the airplane, push the door until it aligns with fuselage and lock it by moving outside handle upwards, then fold handle in its recess.

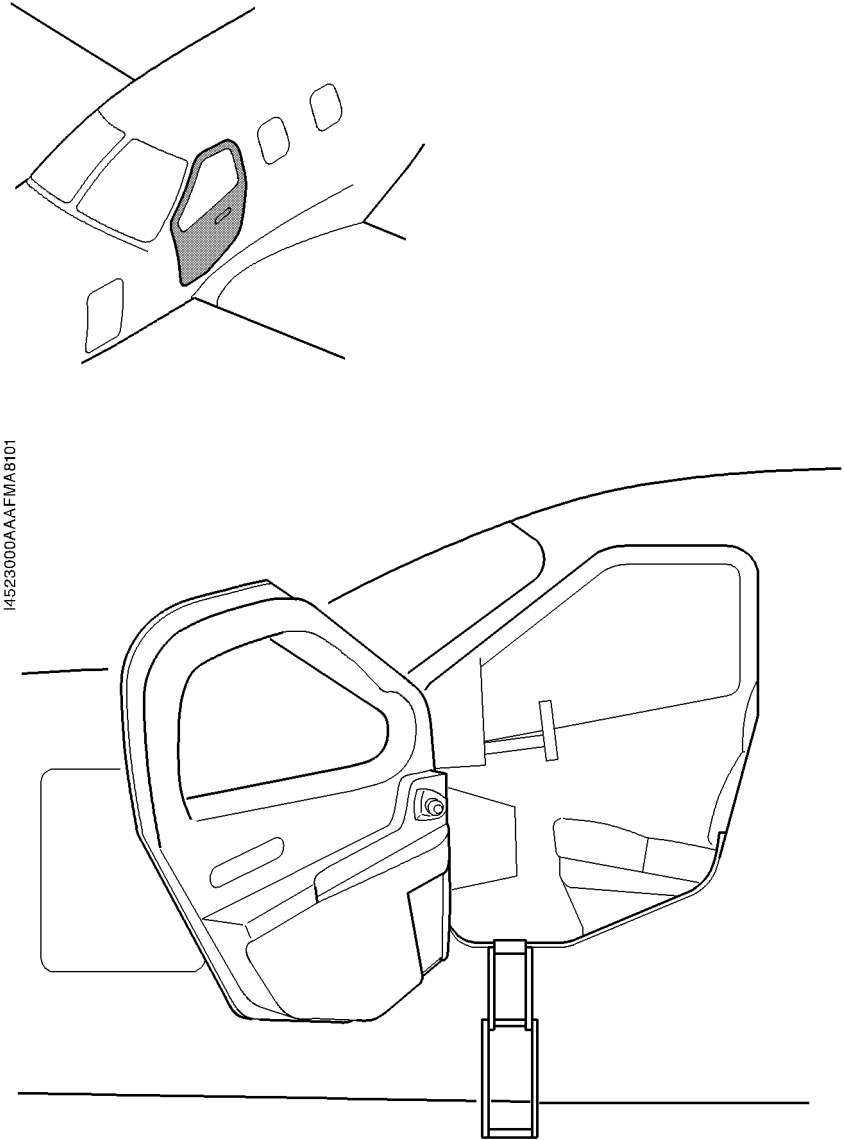

Figure 7.3.9A - COCKPIT ACCESS DOOR ("PILOT" DOOR)

FWD compartment door

The FWD compartment door is located on the airplane left side between the firewall and the front pressure bulkhead. It is hinged at the top. It is maintained in the up position by a compensation rod. Two interlocking-type latches ensure its closing and it is equipped with a lock (same key as for the access door, "pilot" door (if installed) and aft baggage compartment door). When the door is closed, latches are flush with the fuselage profile.

AFT baggage compartment door

The AFT baggage compartment door is located on the airplane left side between the rear pressure bulkhead at frame C17 and the frame C18. It is hinged at the top. It is maintained in the up position by a compensation rod. Two interlocking-type latches ensure its closing and it is equipped with a lock (same key as for the access door, "pilot" door (if installed) and FWD compartment door). When the door is closed, latches are flush with the fuselage profile.

Windows

Windows do not open. The windshield consists of two parts electrically deiced.

Emergency exit (Figure 7.3.10)

The emergency exit is installed on the right side of the fuselage and opens towards the inside. It is equipped with two handles, one inside and the other outside, each located on the upper frame.

When the airplane is parked, the closing system may be locked by a safety pin provided with a flag marker. The handle is then inoperable.

WARNING**TAXIING AND FLYING WITH THIEF-PROOF SAFETY PIN INSTALLED
IS FORBIDDEN.**

To open the emergency exit, pull one of the two handles and tilt the emergency exit from top to bottom towards inside of airplane.

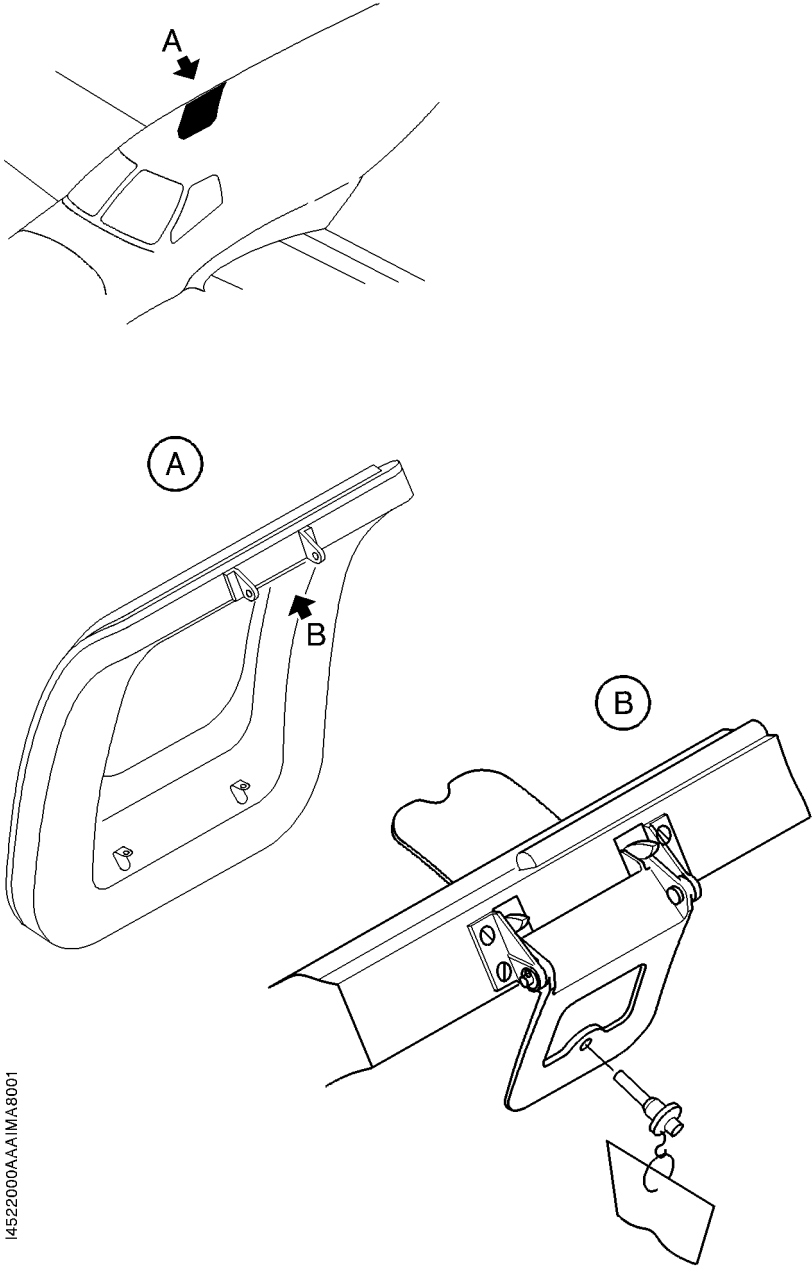

14522000AA1M/A 8001

Figure 7.3.10 - EMERGENCY EXIT

INTENTIONALLY LEFT BLANK

SEATS, BELTS AND HARNESSSES

■ (Refer to Supplement 41 for TBM 700C2 airplane)

Cockpit seats (Figure 7.3.11)

L.H. and R.H. front seats are mounted on rails attached to the structure. Longitudinal position, height and back-rest tilting of each seat can be adjusted and the arm-rest is hinged.

Pull up the handle located forwards (Item 7) for longitudinal setting.

The seat height is adjusted by pulling up side handle (Item 8) while relieving the seat from the body weight.

The seat back angle is adjusted by pulling up side handle (Item 9).

Passengers' seats (Figure 7.3.11)

The standard accommodation consists of two individual seats, installed back to the flight direction, mounted on the same rails as the front seats and two rear seats arranged as a bench.

The back-rest tilting of these seats can be modified.

The rear seat back-rests tilt forward and the rear L.H. seat may tilt forwards to ease baggage loading in baggage compartment.

Belts and harnesses (Figure 7.3.12)

WARNING

INCORRECT CLOSURE OF THE SAFETY BELT MAY INTRODUCE A RISK. MAKE SURE IT IS TIGHTENED WHEN BUCKLED. TO BE MOST EFFICIENT, THE BELT MUST NOT BE TWISTED. CHECK THAT THERE IS NO CONSTRAINT WHEN OPERATED. AFTER A SERIOUS ACCIDENT, REPLACE ALL BELTS

Safety belts consist of three parts : two adjustable half-belts attached to the seat and one harness installed on an inertial reel attached to the structure. The inertial reel allows lengthwise movements as long as they are not sudden, otherwise the reel jams and hinders the displacement of the occupant forward. Harness is linked to belt with its buckle and a pin.

BAGGAGE COMPARTMENTS

There are two baggage compartments :

- a compartment located in the pressurized cabin between rear passenger seats and rear pressure bulkhead,
- an AFT compartment (non-pressurized) located between the rear pressure bulkhead at frame C17 and the frame C18.

The pressurized compartment is accessible through the cabin by tilting forward the L.H. rear seat and / or L.H. or R.H. rear seat back-rests.

The AFT compartment is accessible by opening the external door located on the left side of the airplane.

The floor of the pressurized compartment is equipped with rings fitted with lashing straps provided for securing parcels and baggage on compartment floor.

These locations are designed for the carrying of low density loads ; loading and unloading must be carried out with caution to avoid any damage to airplane.

The cabin is separated from the baggage compartment by a partition net intended to protect the passengers from injuries that could be caused by improper tie-down of a content.

The partition net is mounted at frame C14 (Figure 7.2.1), it is secured at the bottom to 4 points of the floor and on the sides to 6 points of the structure.

The rear (non pressurized) baggage compartment is provided with a holding elastic net.

Maximum loads allowable in baggage compartments depend on airplane equipment, refer to Section 6 "Weight and balance".

WARNING

ANY PARCEL OR BAGGAGE MUST BE STOWED BY STRAPS.

IT IS THE PILOT'S RESPONSIBILITY TO CHECK THAT ALL THE PARCELS AND BAGGAGE ARE PROPERLY SECURED IN THE CABIN.

IN CASE OF TRANSPORT OF DANGEROUS MATERIALS, RESPECT THE LAW CONCERNING TRANSPORT OF DANGEROUS MATERIALS AND ANY OTHER APPLICABLE REGULATION

- 1) Front passenger's seat
- 2) L. H. pilot's seat
- 3) R. H. intermediate passenger's seat (back to flight direction)
- 4) L. H. intermediate passenger's seat (back to flight direction)
- 5) R. H. rear passenger's seat
- 6) L. H. rear passenger's seat } Rear bench
- 7) Front seat(s) longitudinal shift control
- 8) Front seat(s) height control
- 9) Front seat(s) back-rest tilt control
- 10) Drawer for pilot's piddle pak
(front side : new bags, rear side : used bags)
- 11) Intermediate seat(s) back-rest tilt control
- 12) Rear bench seat(s) back-rest tilt control
- 13) Rear bench L.H. seat tilt control

NOTE :

To have access to the baggage compartment, pull forwards the back-rest of rear bench L.H. seat, then pull forwards control (Item 13) to tilt L.H. seat assembly forwards.

If necessary, pull forwards the back-rest of rear bench R.H. seat.

Figure 7.3.11 (1/2) - SEATS

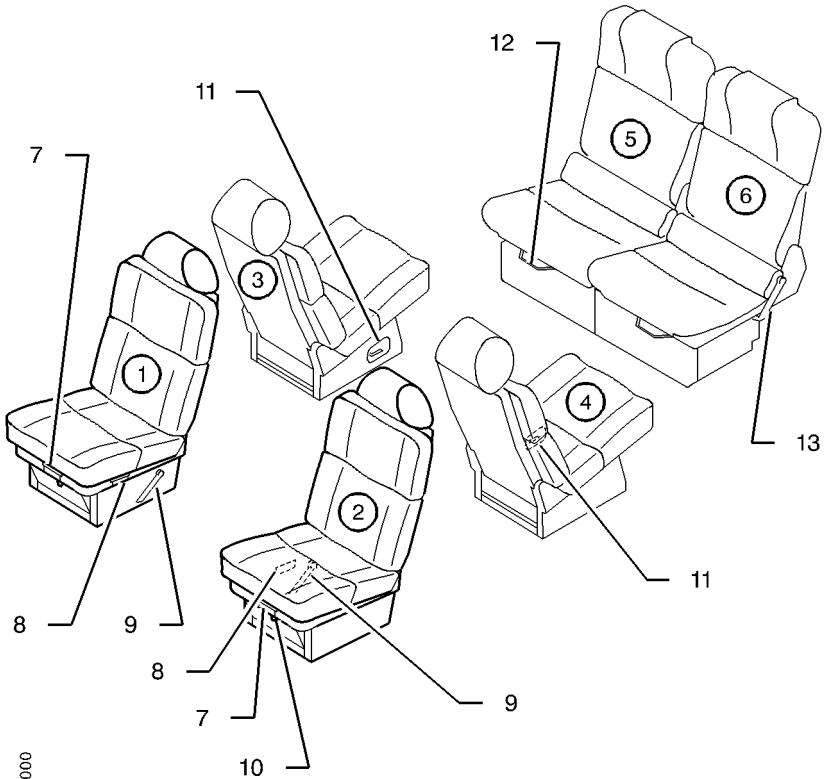

14251100AAADMA18000

Figure 7.3.11 (2/2) - SEATS

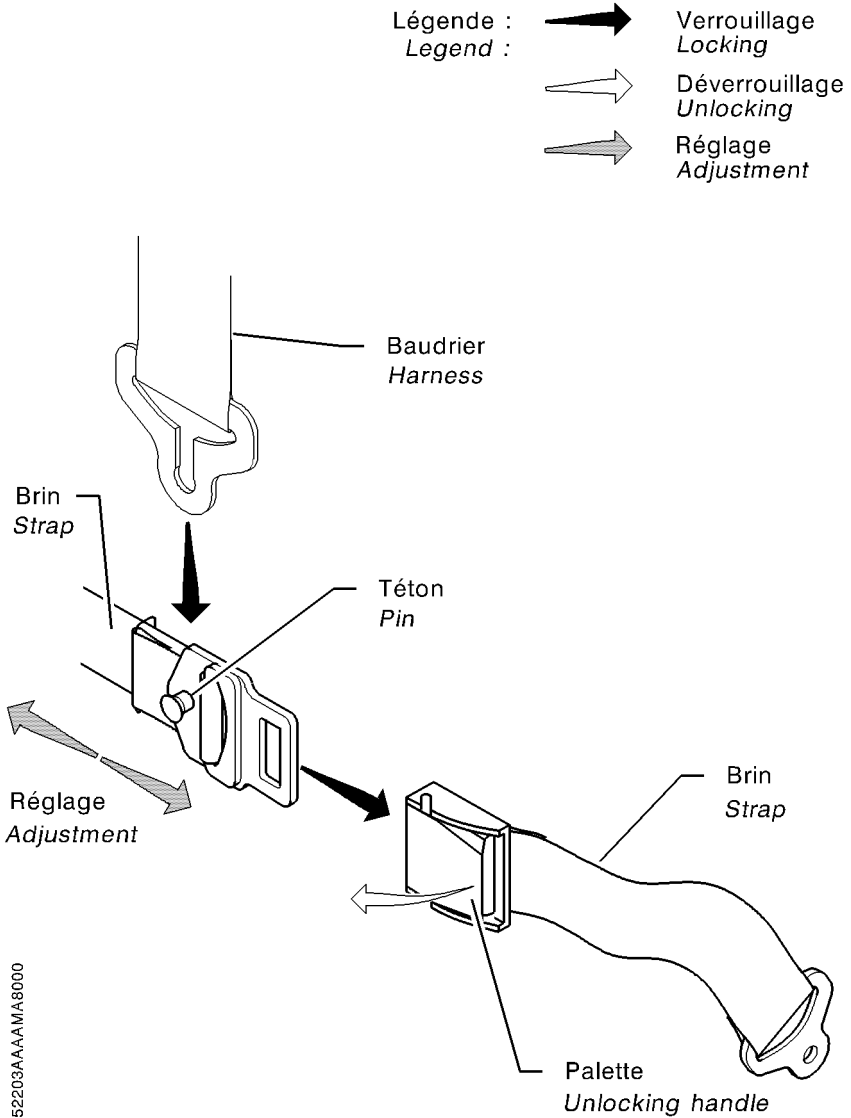

Figure 7.3.12 - FRONT OR REAR SEAT BELT (with movable straps)
AND HARNESSSES

7.4 - FLIGHT CONTROLS

Flight controls consist of roll, pitch and rudder controls, as well as roll trim tab, pitch trim tab and rudder trim tab controls.

NOTE :

During airplane parking, it is recommended to lock flight controls (see Figure 8.6.2)

ROLL (Figure 7.4.1)

The roll control is activated by an assembly of rods and cables which links control wheels with the ailerons and the spoilers.

Aileron displacement is combined with that of spoilers, located at upper surface of each wing forward of flaps.

The spoiler rises from wing upper surface profile, when the aileron is deflected upwards and remains in wing profile, when the aileron is deflected downwards.

Control wheel movement is transmitted through rods to fuselage roll lever located under the floor. The movement is then transmitted through cables to the spoiler mechanism and from the spoiler mechanism to wing roll lever which activates the aileron through a rod.

A rudder / roll combination spring-type system induces roll deflection at the time of pedals movement and vice versa.

ROLL TRIM (Figure 7.4.2)

The roll trim is controlled by a trim tab attached at trailing edge of the L.H. aileron. The trim tab is connected through two links to an electric actuator located in the aileron. A trim switch located on pedestal controls the roll trim tab maneuver.

Roll trim tab electrical circuit is protected by the "AIL-TRIM" circuit breaker.

- 1) Pedestal assembly
- 2) Control wheels
- 3) Fuselage roll lever
- 4) Spoiler
- 5) Aileron
- 6) Aileron control in wing
- 7) Spoiler control

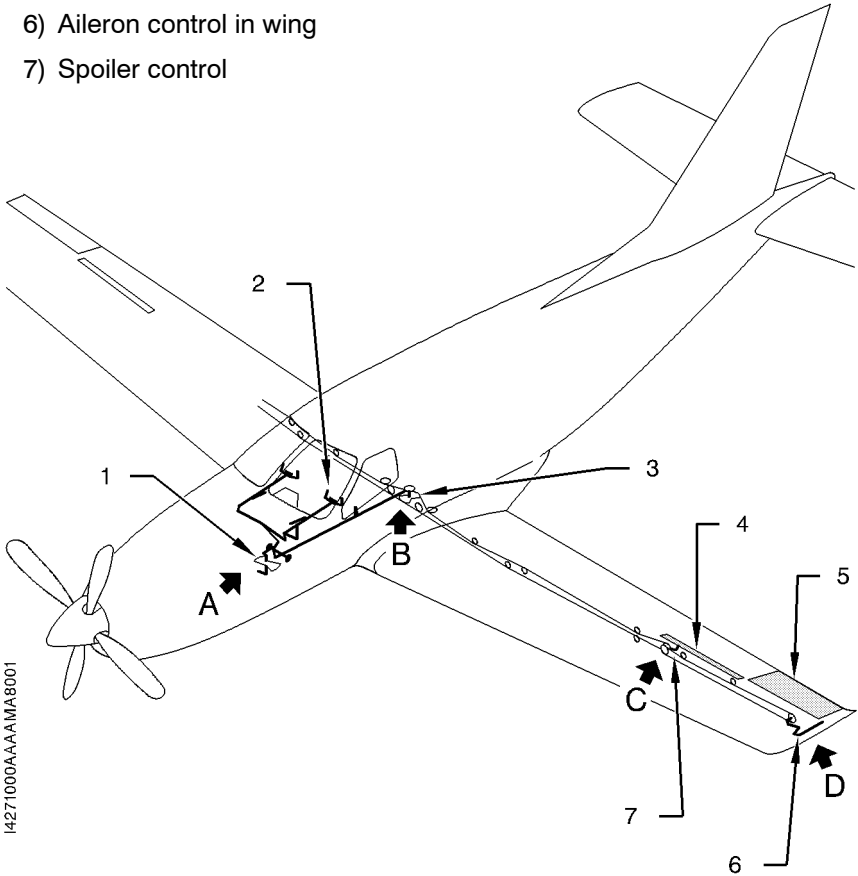

14271000AAAAA8001

Figure 7.4.1 (1/2) - ROLL

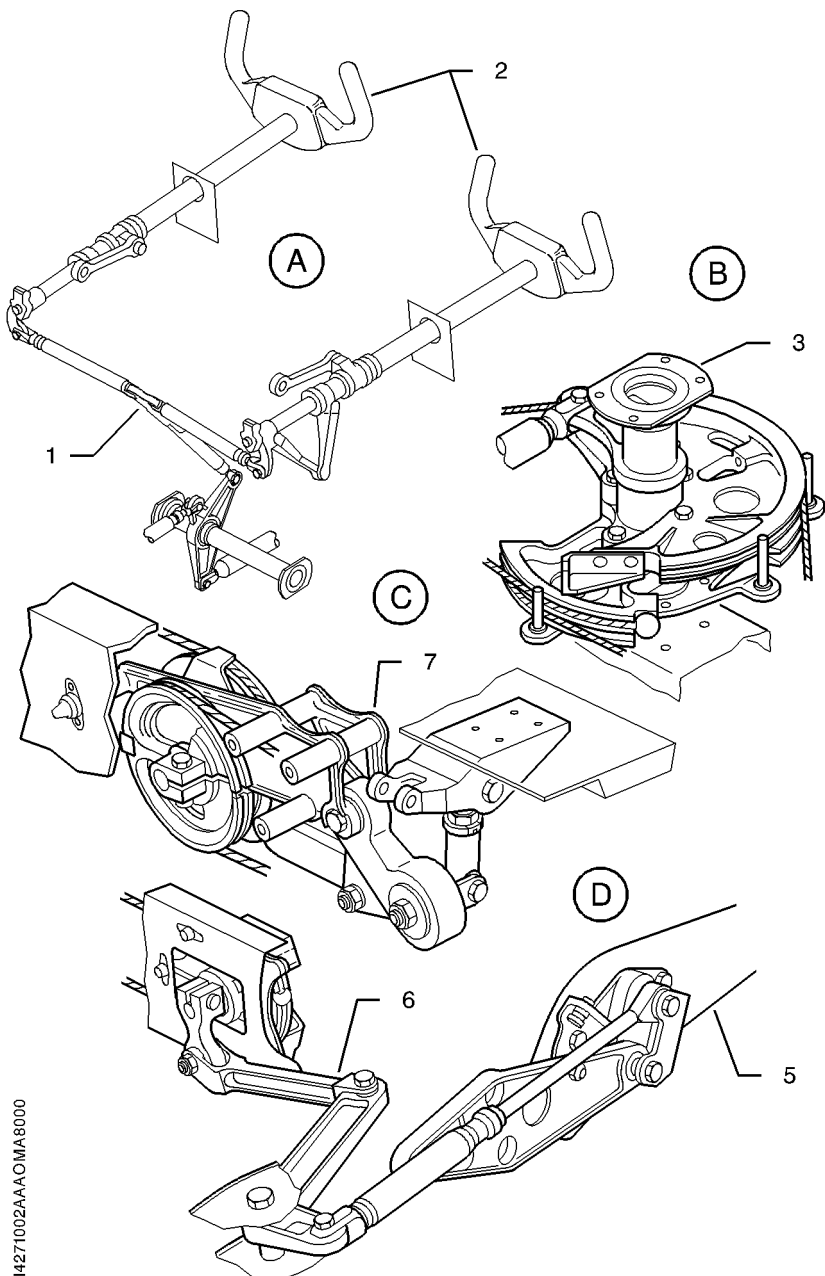

14271002AAAOA8000

Figure 7.4.1 (2/2) - ROLL

- 1) Roll trim tab
- 2) Aileron
- 3) Adjustable rods
- 4) Actuator
- 5) Trim tab control wiring
- 6) Aileron trim tab position indicator
- 7) Trim switch on pedestal console

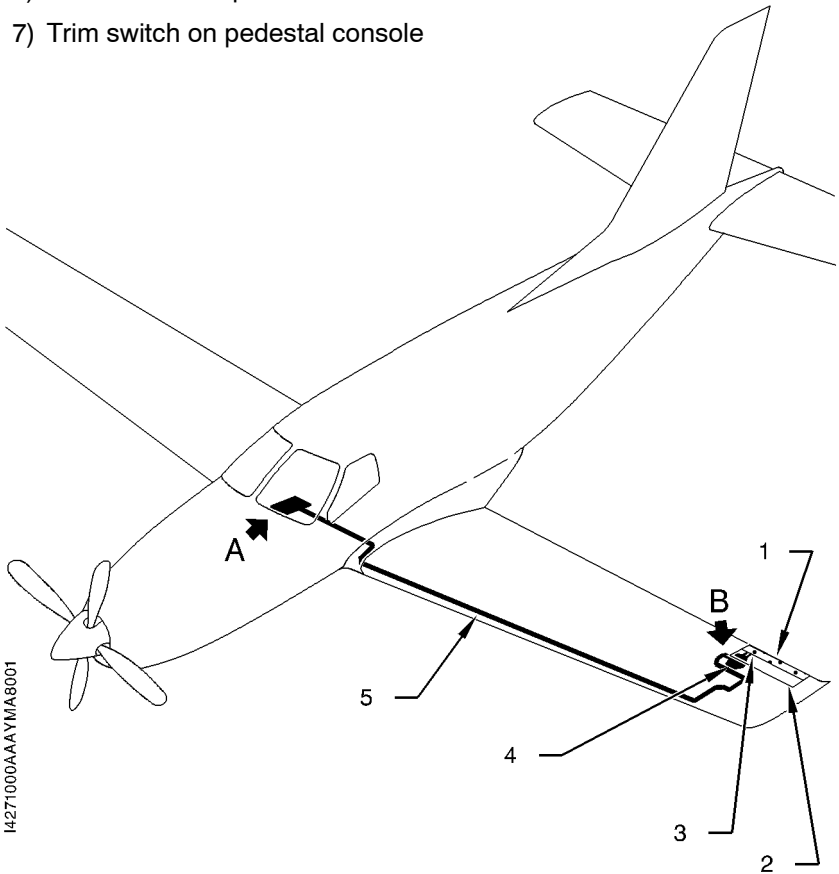

Figure 7.4.2 (1/2) - LATERAL TRIM

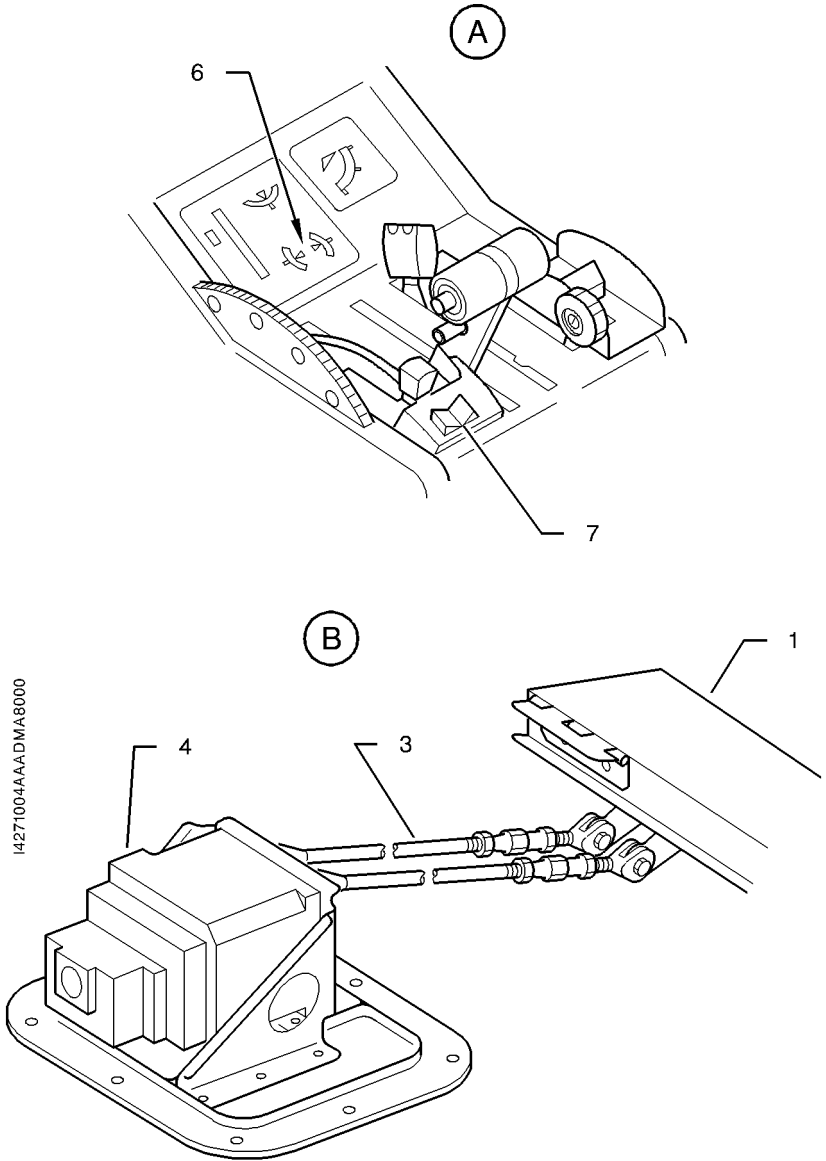

Figure 7.4.2 (2/2) - LATERAL TRIM

INTENTIONALLY LEFT BLANK

ELEVATOR (Figure 7.4.3)

Both elevators are activated simultaneously by the same control. Each control surface is hinged at three points to the rear part of horizontal stabilizer.

The control wheel controls the two elevators through rods, bearings and bellcranks.

A spring actuator creates a "nose-down" artificial force which allows a better static stability.

Each control surface is provided with an automatic anti-tab (automaticity about 0.3), which is also used as trim tab.

PITCH TRIM (Figure 7.4.4)

The pitch trim is accomplished through the two anti-tabs located on left and right elevators.

The trim tab can be controlled electrically or manually. It is activated through cables and a chain on two screw actuators attached to the horizontal empennage.

The electrical control consists of a switch located on the pilot control wheel and a servo-motor attached under the pedestal.

The electrical circuit for pitch trims is protected by the "PITCH TRIM" circuit breaker.

Manual control wheel is installed vertically on left side of pedestal console.

- 1) Control wheel assembly
- 2) Elevators
- 3) Lever assembly, fuselage rear part
- 4) Elevator bellcrank
- 5) Rod with presseal connection
- 6) Lever assembly under floor
- 7) Pedestal assembly
- 8) Actuator

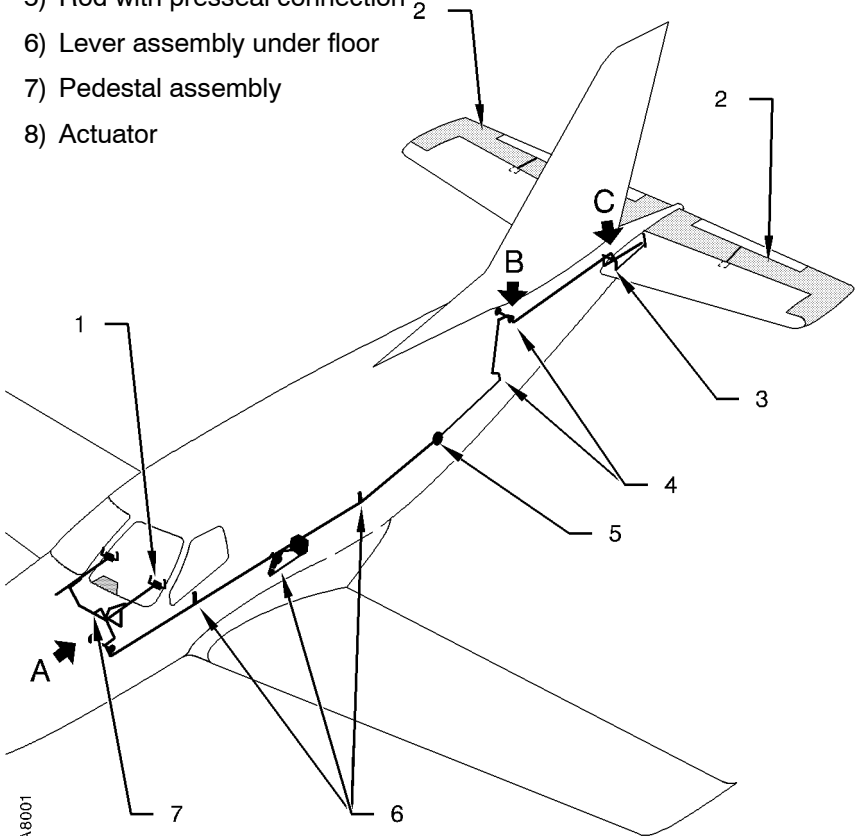

14273000AAAAWA8001

Figure 7.4.3 (1/2) - ELEVATOR

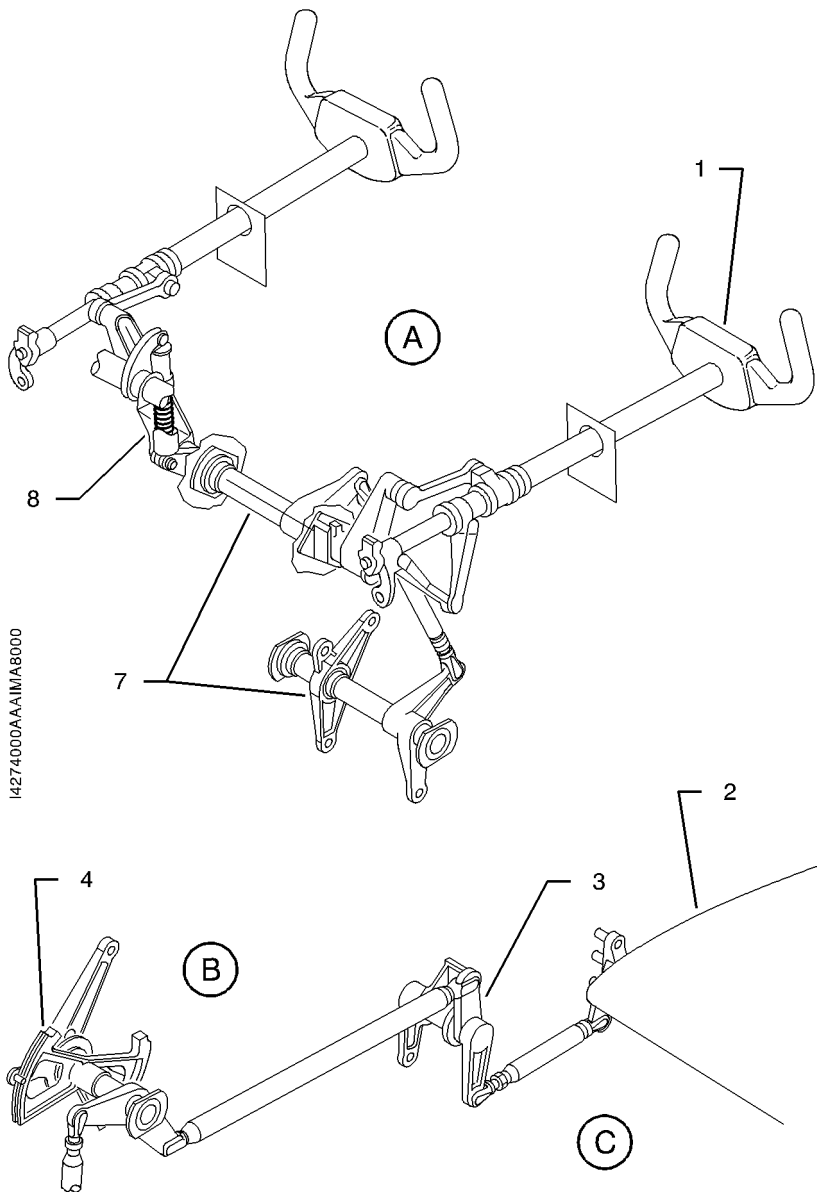
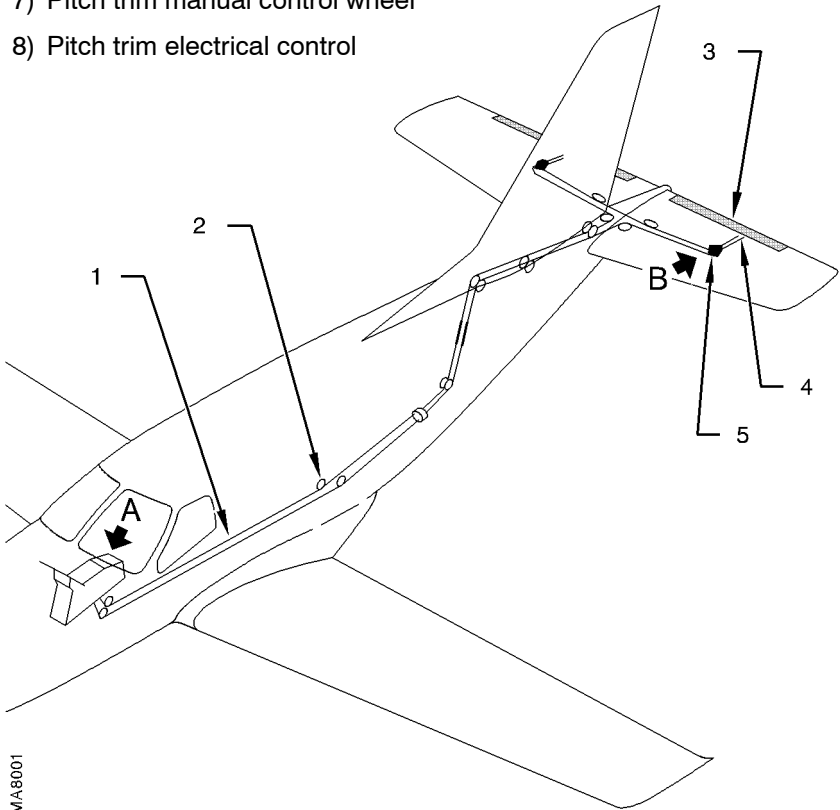

Figure 7.4.3 (2/2) - ELEVATOR

- 1) Cables
- 2) Pulleys
- 3) Pitch trim tabs
- 4) Actuating rods
- 5) Actuator
- 6) Pitch trim tab position indicator
- 7) Pitch trim manual control wheel
- 8) Pitch trim electrical control



14274000AAA.BMA8001

Figure 7.4.4 (1/2) - PITCH TRIM

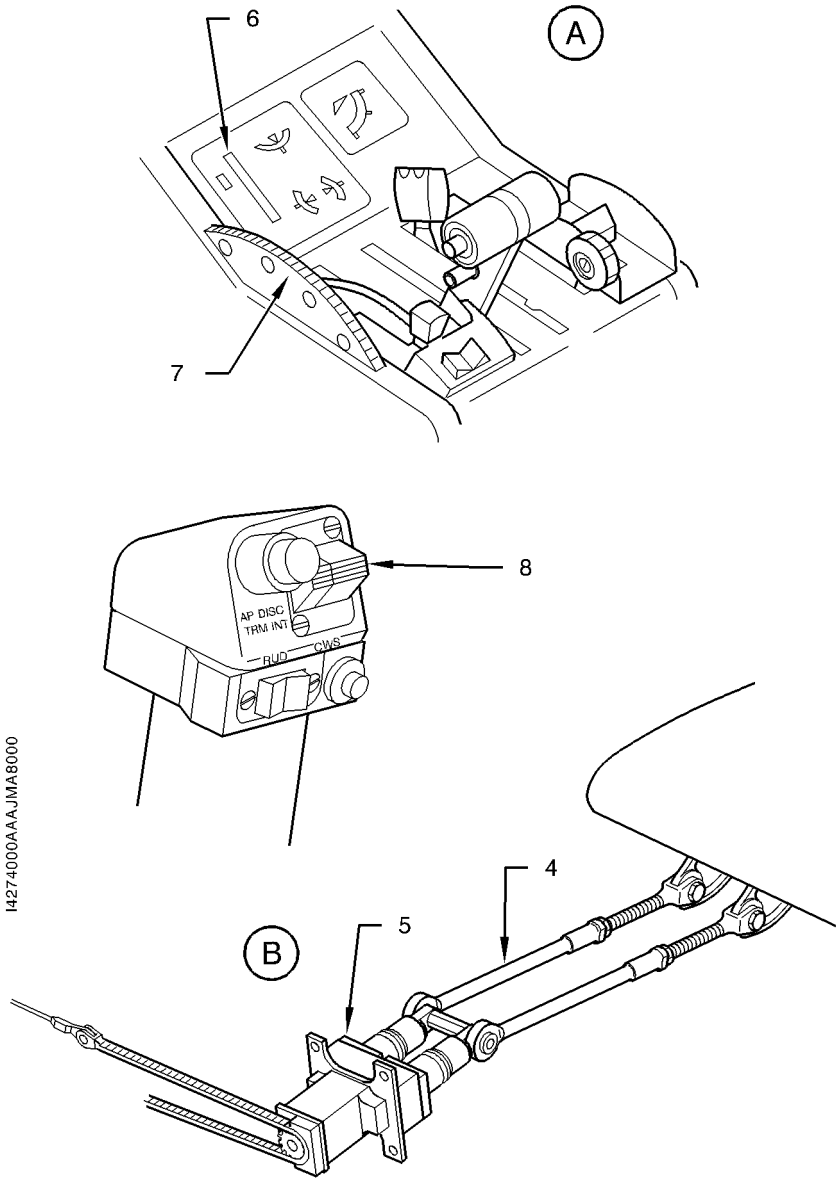

Figure 7.4.4 (2/2) - PITCH TRIM

INTENTIONALLY LEFT BLANK

RUDDER (Figure 7.4.5)

The rudder is hinged on three fittings attached to the vertical stabilizer rear spar.

- The rudder pedals / rudder linkage is ensured through cables and a rod.

Pilot and R.H. station rudder pedal positions are adjustable at each station. The rudder pedal adjustment mechanism (for piloting comfort purposes) includes a manual control located against the external bulkhead beneath the instrument panel and a locking device on the rudder pedals. This ball locking device allows selecting six different positions.

When landing gear is down, rudder pedals are linked to nose gear steering system.

Spring system of rudder / roll combination induces aileron deflection at the time of pedal displacement and vice versa.

RUDDER TRIM (Figure 7.4.6)

A trim tab hinged at two points located at rudder trailing edge provides rudder trim.

Trim tab is linked by two rods to an electric actuator attached to rudder. It is controlled by "RUD" switch (L / R) located on pilot control wheel.

Electrical circuit of rudder trim tab is protected by "RUD TRIM" circuit breaker.

- 1) Roll / rudder combination bellcrank installation
- 2) Rudder pedals assembly
- 3) Control cables
- 4) Pulleys
- 5) Rudder lever assembly
- 6) Rod
- 7) Rudder
- 8) Nose gear steering rod

I4272000AAAAMA8001

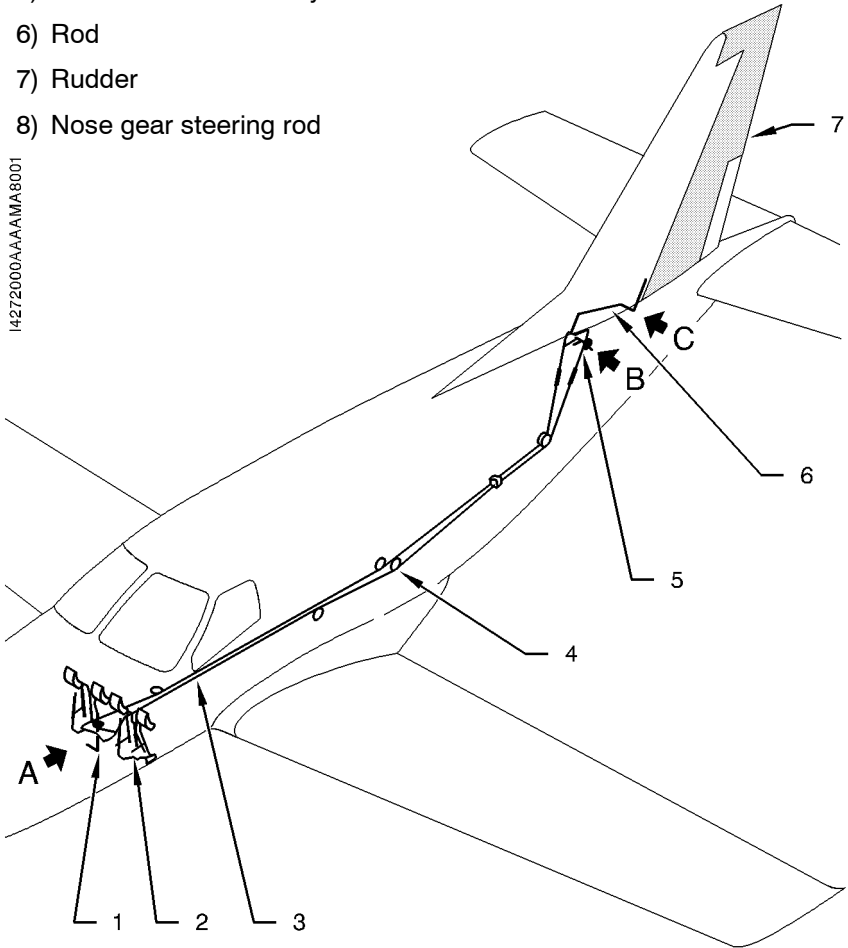

Figure 7.4.5 (1/2) - RUDDER

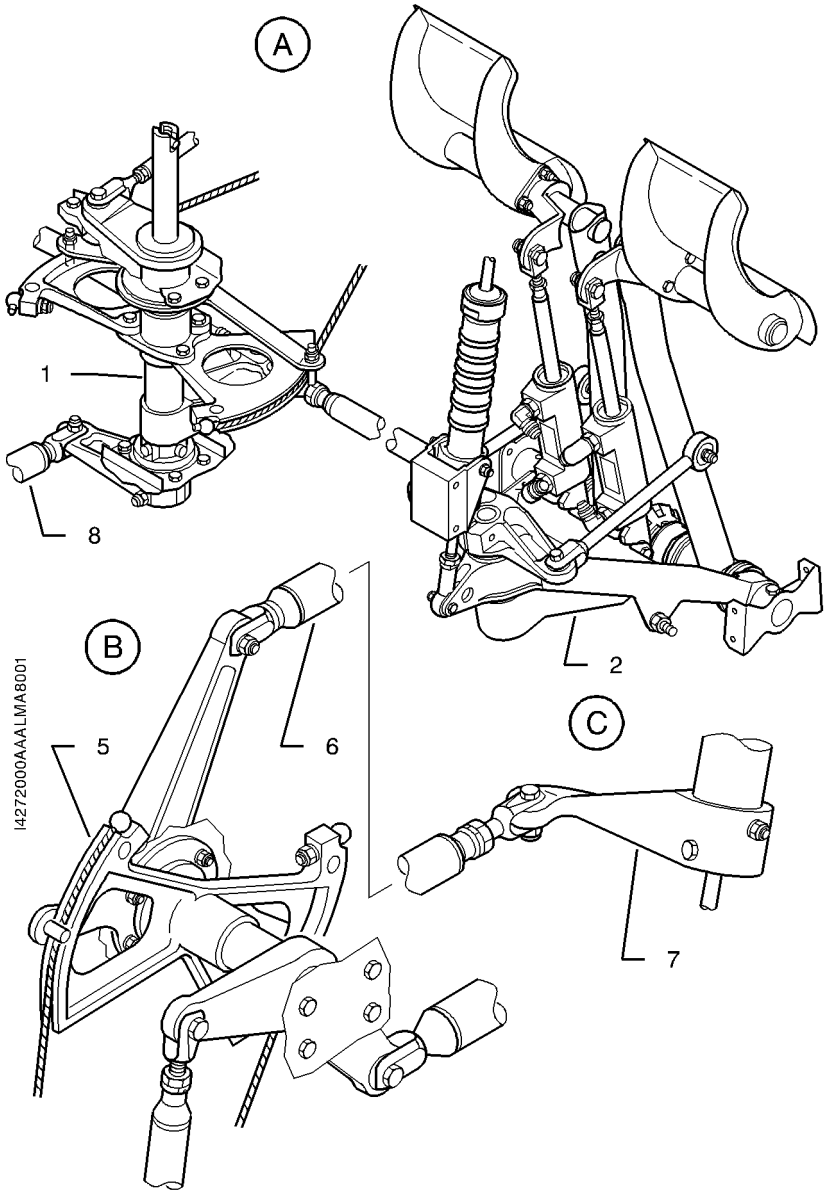

Figure 7.4.5 (2/2) - RUDDER

- 1) Trim switch on control wheel
- 2) Actuator
- 3) Rudder trim tab
- 4) Rods
- 5) Rudder trim control wiring
- 6) Rudder trim tab position indicator

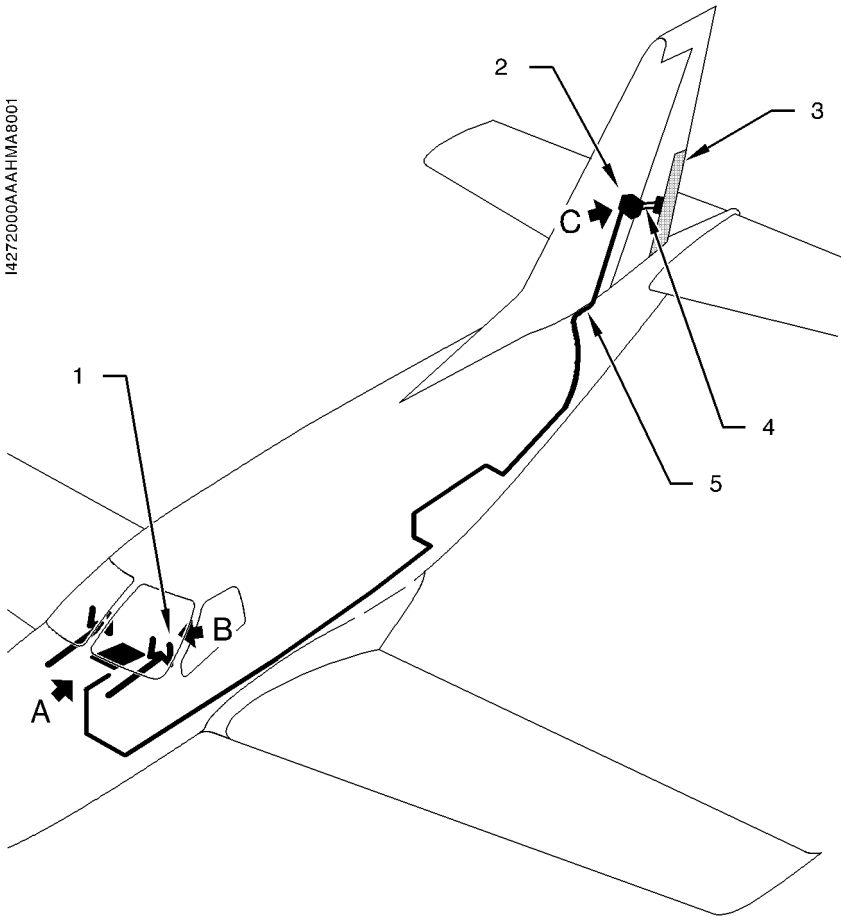
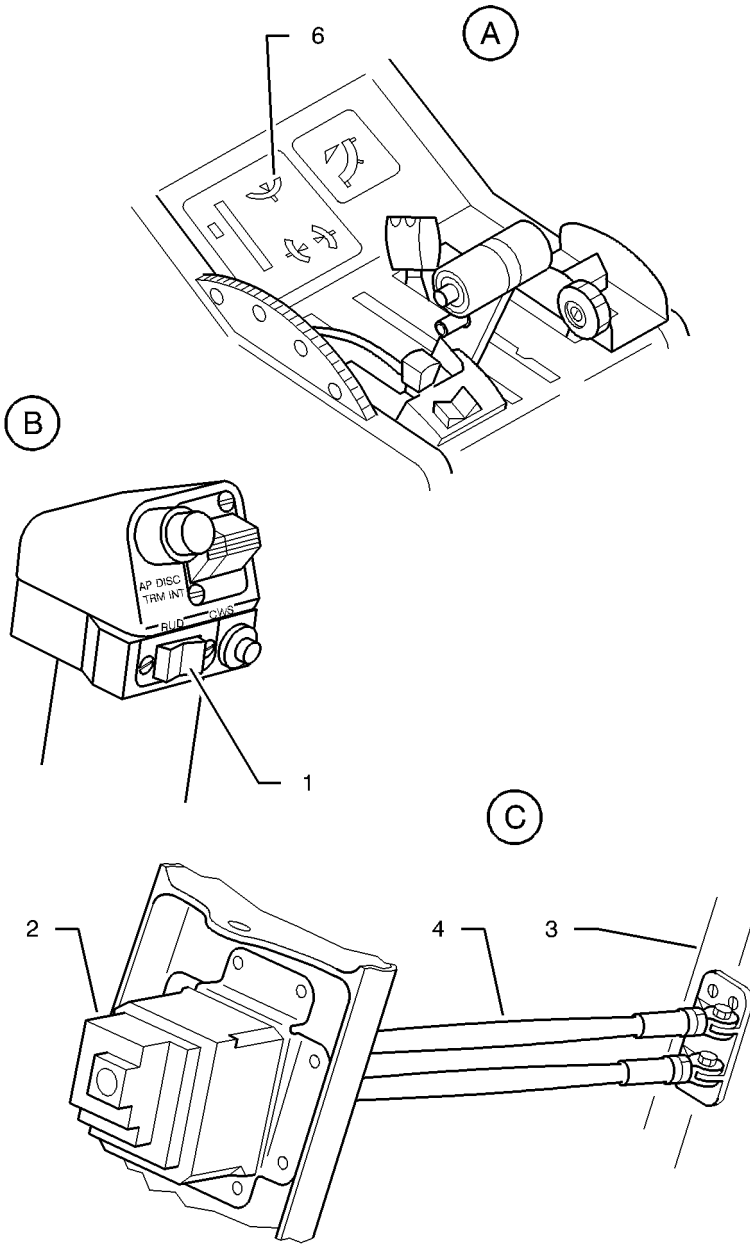

Figure 7.4.6 (1/2) - RUDDER TRIM



14272002AAAAGMA8000

Figure 7.4.6 (2/2) - RUDDER TRIM

INTENTIONALLY LEFT BLANK

7.5 - LANDING GEAR

The TBM 700 is equipped with electro-hydraulically actuated, fully retractable tricycle landing gear.

Each landing gear is equipped with one wheel and an oil-air shock absorber integrated in the strut.

Main landing gears swivel on two ball joints installed on wing spars. Each landing gear retracts toward airplane centerline. The operation is accomplished by a hydraulic actuating cylinder which also provides up and down locking.

Nose gear swivels on two ball joints installed on a tubular steel mount frame. Its operation is accomplished by a hydraulic actuating cylinder which also provides up and down locking. The nose wheel is steerable. It is connected to pedals through a spring rod and is provided with a shimmy damper. In UP position, nose wheel is automatically disconnected.

Actuating cylinders have a locking device integrated at both ends. This device maintains landing gear in up or down position.

Landing gear doors, two on the nose gear, one on each main landing gear, are driven and kept in UP position by the landing gear itself.

All doors are mechanically kept in down position.

HYDRAULIC PRESSURE

- **Hydraulic pressure** required for landing gear operation is accomplished :
 - during normal operation, by an electro-hydraulic generator with integrated reservoir,
 - during emergency extension operation by a hand pump supplied with an auxiliary reservoir.

LANDING GEAR CONTROL (Figure 7.5.1)

Landing gear control, located on "LANDING GEAR" panel at the bottom of instrument panel left part, is accomplished by an electric selector actuated through a lever ending with a knob representing a wheel. Operation is carried out by pulling on lever and by putting it in the desired "UP" (retracted) or "DN" (extended) position. This selector controls hydraulic generator.

LANDING GEAR INDICATOR (Figure 7.5.1)

Landing gear position indication is accomplished by 4 warning lights :

- 3 green indicator lights (one per landing gear) indicate that each landing gear is down-locked,
- 1 red warning light indicates that landing gears are operating, or not locked down or up.

NOTE :

The red warning light flashes as soon as landing gears are operating and remains continuously on in case of locking problem.

When landing gear is correctly retracted, all warning lights are OFF. In case of doubt about "landing gear down-locked" position, an independant electrical circuit with the "CHECK DN" switch on the same panel as the warning lights allows testing of the control circuit, therefore providing a countercheck capability of the indication system.

Indication panel is provided with two tests which allow checking green indicator lights and red warning light bulbs through two distinct electric power supplies.

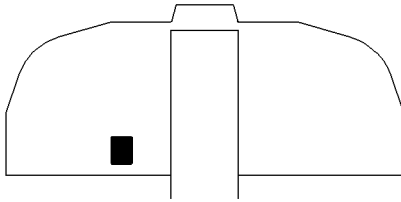

- 1) Red warning light (LDG GR)
- 2) Green indicator light (LDG GR)
- 3) Landing gear control selector
- 4) Test switch
- 5) Test knobs

14326001AAABMA8000

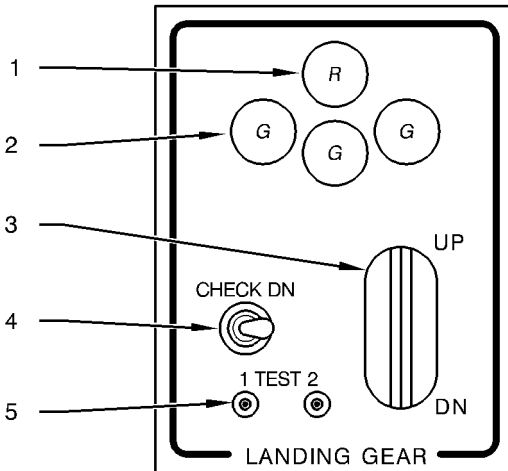

Figure 7.5.1 - CONTROL PANEL AND LANDING GEAR INDICATING

SAFETY

Safety switch (landing gear retraction)

A safety switch installed on each main landing gear prevents, by detecting shock strut compression, landing gear accidental retraction when airplane is on ground.

Landing gear horn

Landing gear horn is controlled by power lever and / or flaps. It sounds (continuous high-pitched sound) when :

- power lever is on IDLE position and landing gear is not down-locked,
- flaps are beyond "TO" position (Takeoff) and landing gear is not down-locked.

NOTE :

If one of above conditions exists and airplane is in stall configuration, the audio-warning signal becomes alternated (high-pitched sound / low-pitched sound).

Emergency landing gear extension control (Figure 7.5.2)

Emergency landing gear extension control consists of a hand pump and a by-pass selector.

This control is accessible by removing the floor panel located aft of the pedestal.

After bypass selector closing, hand pump operation sends hydraulic fluid directly into landing gear actuators ; landing gear full extension and locking requires up to 110 cycles.

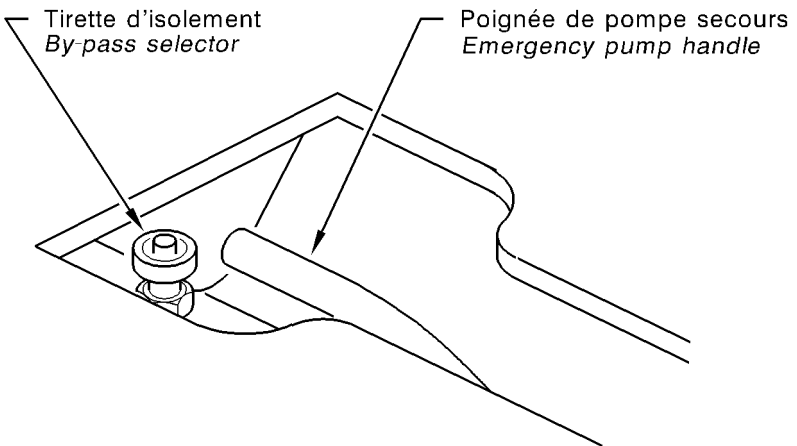
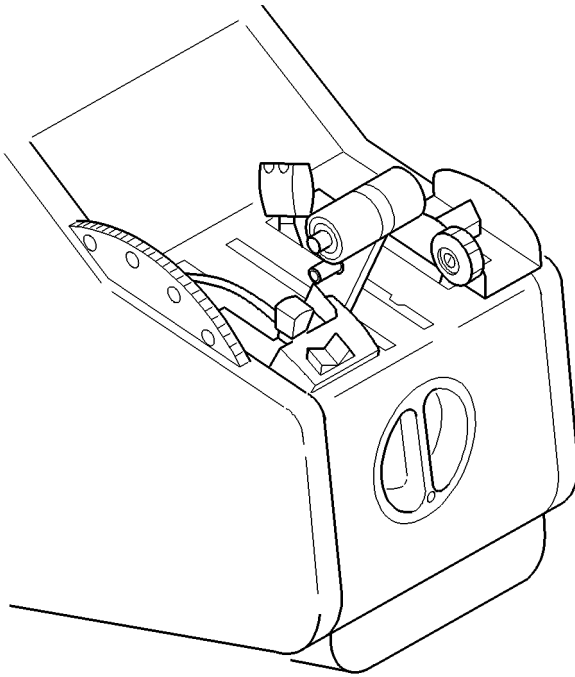

14323500AAAQMA8001

Figure 7.5.2 - EMERGENCY LANDING GEAR EXTENSION CONTROL

GROUND MANEUVERS

Nose gear steering control (Figures 7.5.3 and 7.5.4)

Nose gear steering control is combined with rudder pedals and is fitted with a shimmy damper. When one of rudder pedals is fully pushed, nose wheel swivels about 20°. Steering may be increased up to 28° by applying differential braking to each side.

Airplane may be towed by attaching a steering or towing bar on nose gear (Refer to Chapter 8.6 for operation). In that case nose wheel steering angle is limited to $\pm 28^\circ$.

Minimum turn diameter

Minimum turn diameter, Figure 7.5.4, is obtained by using nose gear steering and differential braking. Since tight turns lead to untimely tire wear, turns should be made using the largest possible turning radius.

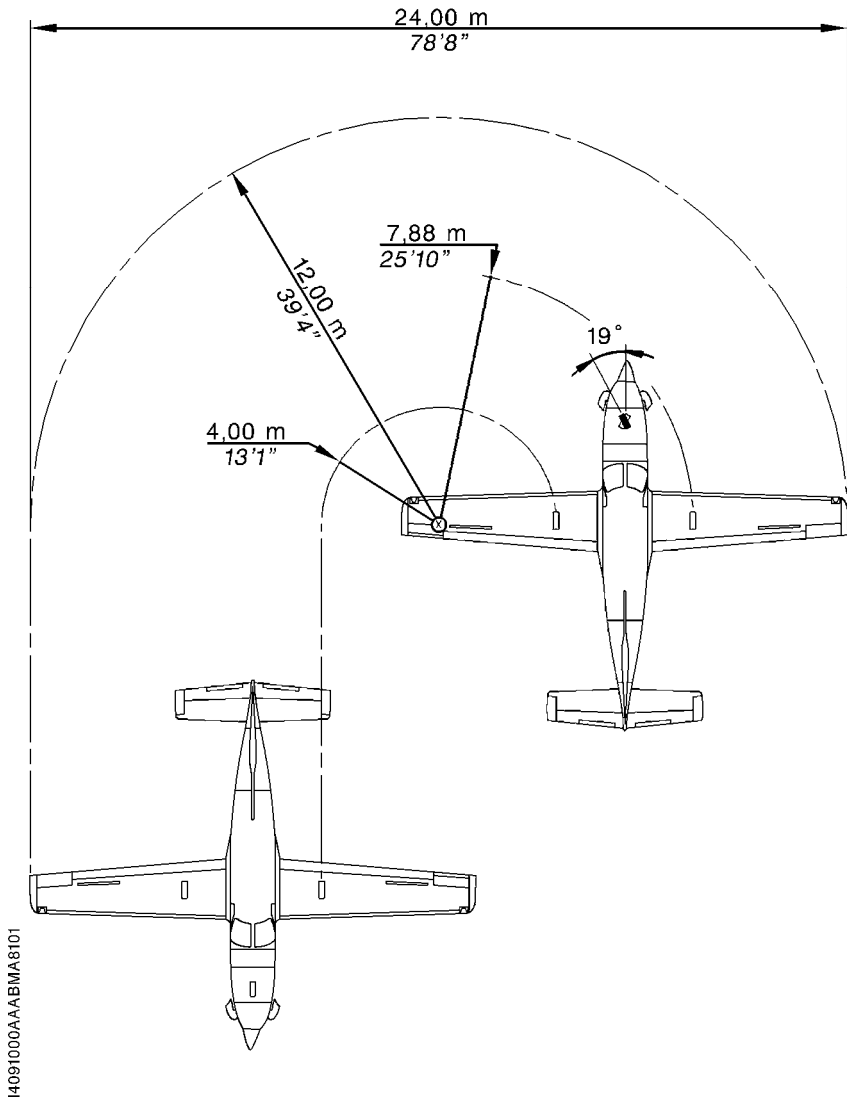
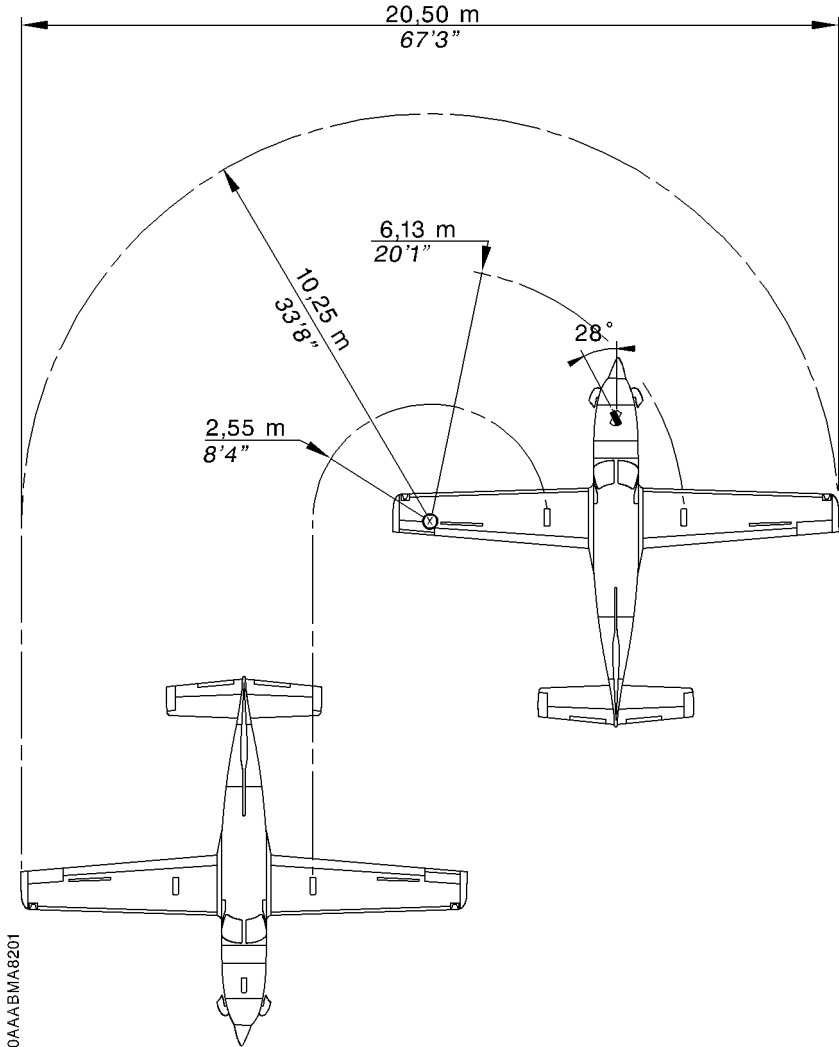

Figure 7.5.3 - MINIMUM TURN DIAMETER
(Full rudder pedals travel without
using differential braking)



14091000AAABMA8201

Figure 7.5.4 - MINIMUM TURN DIAMETER
(Full rudder pedals travel by
using differential braking)

BRAKE SYSTEM (Figure 7.5.5)

Airplane is equipped with a hydraulically actuated disc braking system installed on the main landing gear wheels.

Each toe brake at L.H. and R.H. stations is equipped with a master cylinder which sends hydraulic pressure to the corresponding disc brake : L.H. pedals L.H. brake ; R.H. pedals R.H. brake. This differential braking helps maneuvering during taxiing.

PARKING BRAKE (Figures 7.5.5 and 7.5.6)

Parking brake control consists of a control knob located on pilot's side lower instrument panel, a valve which regulates brake pressure and a "PARK BRAKE" warning light located on advisory panel.

To apply parking brake, press on toe brake of rudder pedals and position control knob on "ON".

"PARK BRAKE" warning light illuminates when control knob is positioned on "ON".

NOTE :



Operating the parking brake knob without applying pressure on rudder pedals does not cause the wheels to be braked.

To release the parking brake, turn the selector to the left in order to set the index upwards to "OFF" position and check at the same time that the "PARK BRAKE" warning light is OFF.

- 1) Reservoir
- 2) Vent
- 3) R.H. station master cylinders
- 4) Parking brake control knob
- 5) Parking brake valve
- 6) Drain
- 7) Pilot's station master cylinders
- 8) L.H. brake assembly
- 9) R.H. brake assembly

Figure 7.5.5 (1/2) - BRAKE SYSTEM

Légende - Key

-  Tuyauterie souple alimentation
Supply hose
-  Tuyauterie flexible pression
Pressure flexible pipe
-  Tuyauterie rigide pression
Pressure rigid pipe

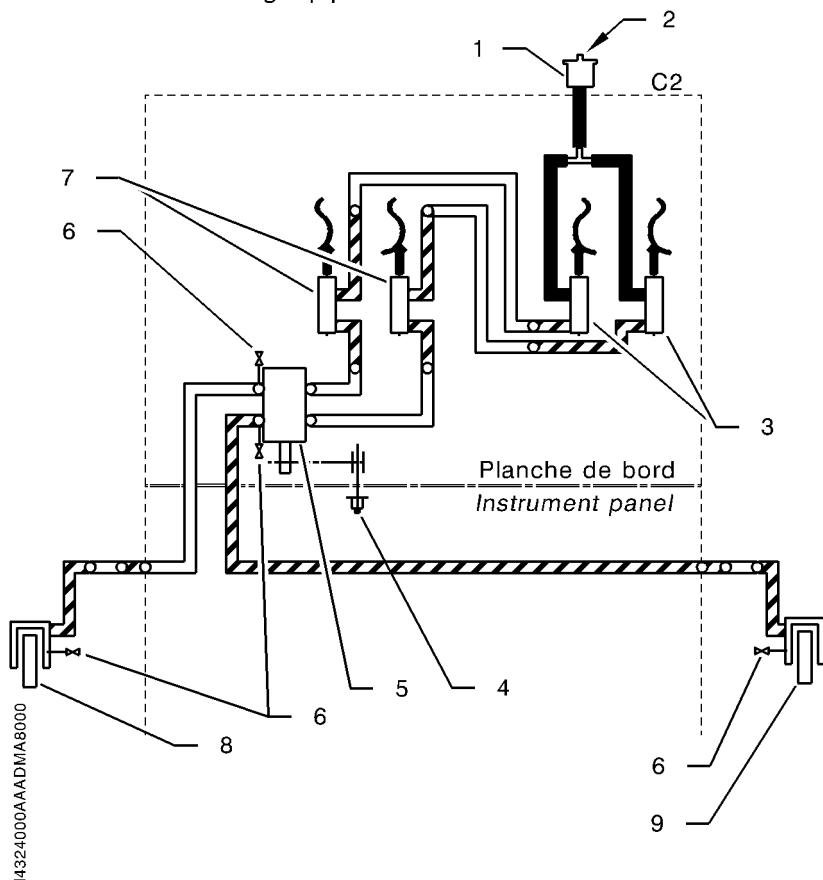
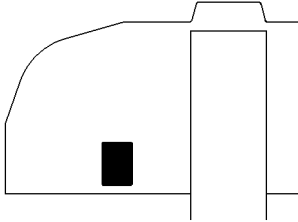

Figure 7.5.5 (2/2) - BRAKE SYSTEM



14351000AAAAA6202

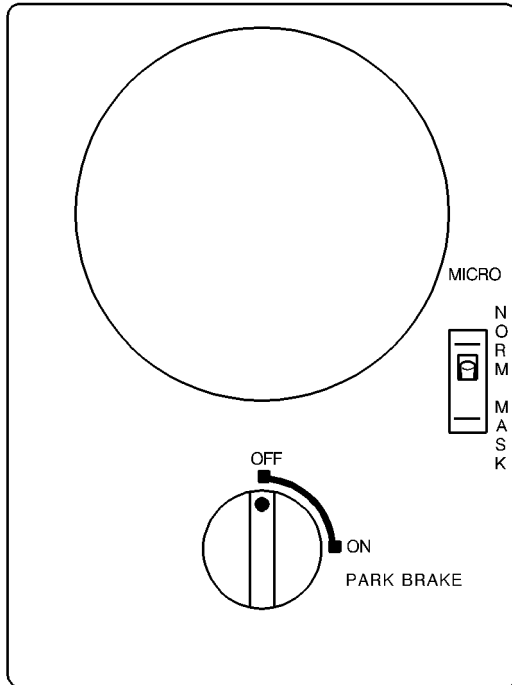

Figure 7.5.6 - PARKING BRAKE

7.6 - POWERPLANT

TURBOPROP ENGINE OPERATION (Figure 7.6.1)

The PRATT & WHITNEY CANADA turboprop engine (PT6A-64 type) is a free turbine engine developing thermodynamic power of 1580 SHP, derated to 700 SHP.

Intake air enters engine through an annular casing and is then ducted toward compressor. The latter consists of four axial stages and one single centrifugal stage assembly to form a whole assembly. Compressed air and fuel are mixed and sprayed into combustion chamber by fuel nozzles. The mixture is first ignited by two spark igniter plugs, then combustion continues as a result of air-fuel mixture flow. Gases resulting from combustion expand through a series of turbines. The first one (gas generator turbine) drives compressor assembly and accessories, the two other ones (power turbines), independent from the first one, drive propeller shaft through a reduction gear box. Hot gases are evacuated through two exhaust stubs located laterally on both sides forward of engine cowling.

All engine driven accessories, except power turbine tachometer and propeller governor, are installed on accessory gearbox located rearward of engine.

PRATT & WHITNEY CANADA PT6A-64 turboprop engines do not require any specific running-in procedure. They can be safely used in all normal ranges allowed by the manufacturer at the time of delivery of the airplane or a new engine or an engine having undergone an overhaul.

- 1) Propeller governor
- 2) Exhaust stub
- 3) Axial compressors
- 4) Accessory gearbox
- 5) FCU Fuel control unit
- 6) Oil to fuel heater
- 7) Compressor stubshaft
- 8) Air intake
- 9) Centrifugal impeller
- 10) Combustion chamber
- 11) Compressor turbine
- 12) Power turbine 1st stage
- 13) Power turbine 2nd stage
- 14) Power turbineshaft

Figure 7.6.1 (1/2) - POWER PLANT

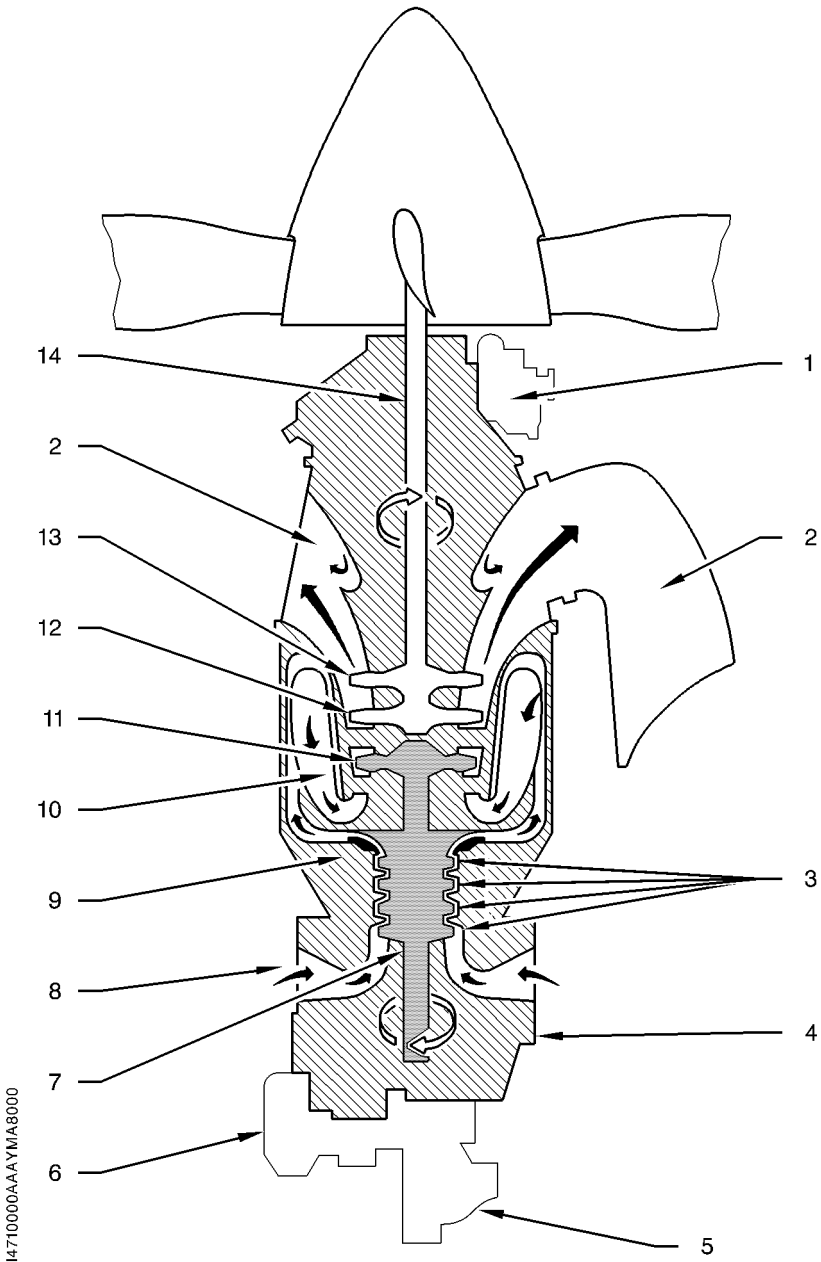

Figure 7.6.1 (2/2) - POWER PLANT

ENGINE CONTROLS (LEVERS) (Figure 7.6.2)

Engine operation requires use of four levers located on pedestal console in cabin :

- power lever (Item 2), and its detent for reverse (Item 6)
- propeller governor lever (Item 1),
- condition lever (Item 3),
- "MAN OVRD" emergency fuel regulation lever (Item 5),

NOTE :

Thumbwheel for lever friction (Item 4)

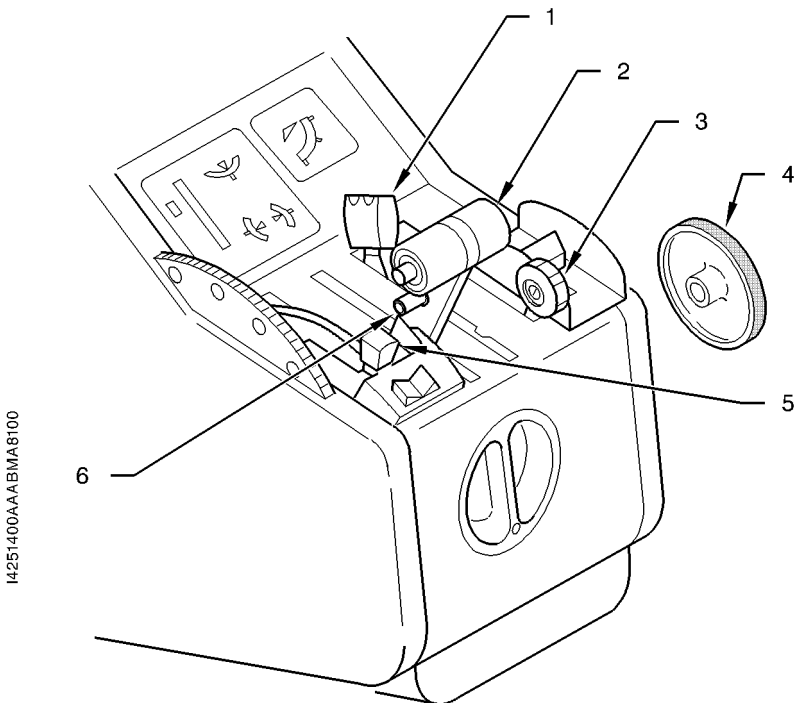

I4251400AAAB1MA8100

Figure 7.6.2 - ENGINE CONTROLS (LEVERS)

Power control lever

The power control lever is linked to fuel control unit. It modulates engine power from full reverse to takeoff.

Engine running, the power control lever rearward displacement, past the lock using the detent, allows to control :

- the engine power in the Beta range from idle to maximum reverse,
- the Beta valve to select the propeller pitch in reverse.

Return to idle position is accomplished by pushing the power control lever forward.

CAUTION

DO NOT MOVE THE COCKPIT POWER CONTROL LEVER INTO THE PROPELLER REVERSE POSITION OR DAMAGE TO THE LINKAGE WILL RESULT.

REVERSE MAY ONLY BE SELECTED WITH ENGINE RUNNING AND PROPELLER TURNING

When engine is shutdown, there is no oil pressure in the propeller and the feathering spring locks the Beta ring and the propeller reversing interconnect linkage on the engine.

All rearward effort on the power control lever, past the idle stop, may damage or break the flexible control cable.

Propeller governor lever

The propeller governor lever activates the propeller governor located forward of the engine to select and maintain any propeller speed between 1600 and 2000 RPM. This lever allows propeller feather. Changing from normal range to feather position requires "FEATH" stop by moving lever toward left side and back. The lever being locked in feather position, unlocking requires moving the lever toward left side and forward.

Condition lever

The fuel condition lever is linked to FCU. It can be positioned to cutoff, idle LO / IDLE or idle HI / IDLE. Change from idle LO / IDLE to cutoff position is only possible after having overridden the idle gate. To override idle gate, raise lever and move it rearwards. If the lever is locked in cutoff position, unlocking is performed by raising lever and moving it forward.

Post-MOD70-0256-76

The fuel condition lever has a "HI / IDLE" locked position. Change from idle "HI / IDLE" to "LO / IDLE" position is only possible after having overridden the idle gate. To override idle gate, raise lever and move it rearwards.

"MAN OVRD" emergency fuel regulation lever

Emergency fuel regulation lever is normally in locked position. In case of FCU or power lever failure, it allows setting engine power manually. Unlocking and locking are performed by pulling lever knob up.

NOTE :

The power available if the power lever fails will be limited by the position of the lever.

Lever friction (Figure 7.6.2)

A thumbwheel (Item 4) located on right side of pedestal console increases friction to avoid control slip after setting.

ENGINE INSTRUMENTS (Figure 7.6.3)

Engine indicating panel consists of the following instruments : a torquemeter, a propeller speed indicator, an ITT indicator, a gas generator speed indicator, an oil pressure and temperature indicator, an Engine Trend Monitoring (ETM) indicator/computer.

Torquemeter (TRQ) indicates engine torque expressed in percent (%).

Propeller speed indicator (PROP) indicates propeller speed in RPM.

ITT indicator indicates gas temperature between generator turbine and power turbine by a dual display (pointer and digital indication). Gages are graduated in "°C".

NOTE :

Interturbine temperature check is also assured by the "ITT" red warning light that illuminates on advisory panel when interturbine temperature exceeds 800 °C.

Gas generator speed indicator (Ng) indicates generator rotation speed expressed in percent (%).

Oil pressure and temperature indicator (ENG OIL) is a dual indicator graduated in "°C" and in PSI.

NOTE :

Each instrument is provided with marks indicating utilization limits. Lubrication system monitoring is ensured by "OIL PRESS" warning light, which illuminates on advisory panel when engine oil pressure is too low.

The Engine Trend Monitoring system (ETM) (Figure 7.6.4) is designed to monitor, display and record all engine operation parameters as well as aerodynamic airdata. The system provides the pilot with a centralized source of information for engine monitoring, fuel management, navigation and airdata parameters.

NOTE :

The ETM system cannot be considered as a primary source with regard to power and associated engine limits monitoring, as well as fuel management.

The most important information can be recorded anytime in the ETM system. Once analyzed, these records make it possible to immediately detect any deviations of the operating parameters and thus schedule appropriate maintenance operations.

Any exceedance in operating parameters is automatically recorded. The ETM can be connected to a navigation system (GPS).

The system consists of three major components :

- the panel-mounted indicator/computer
- the various engine and environment transducers
- the external data recorder with the datakey, located under the L.H. back seat

"PROP O' SPEED TEST" button allows checking the overspeed valve for correct operation.

"ITT TEST" button allows checking the ITT indicator for correct operation :

- digital display **"1888"**
- the pointer abuts against maximum limit
- the "ITT" indicator light illuminates on the advisory panel.

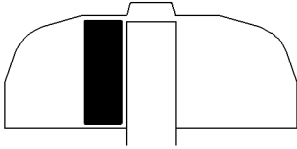

I477000AAAEM/AB100

- 1) Torque indicator
- 2) "PROP O'SPEED TEST" knob
- 3) Propeller indicator
- 4) ITT indicator
- 5) ITT test knob
- 6) Ng indicator
- 7) Oil pressure and temperature indicator
- 8) ETM indicator/computer

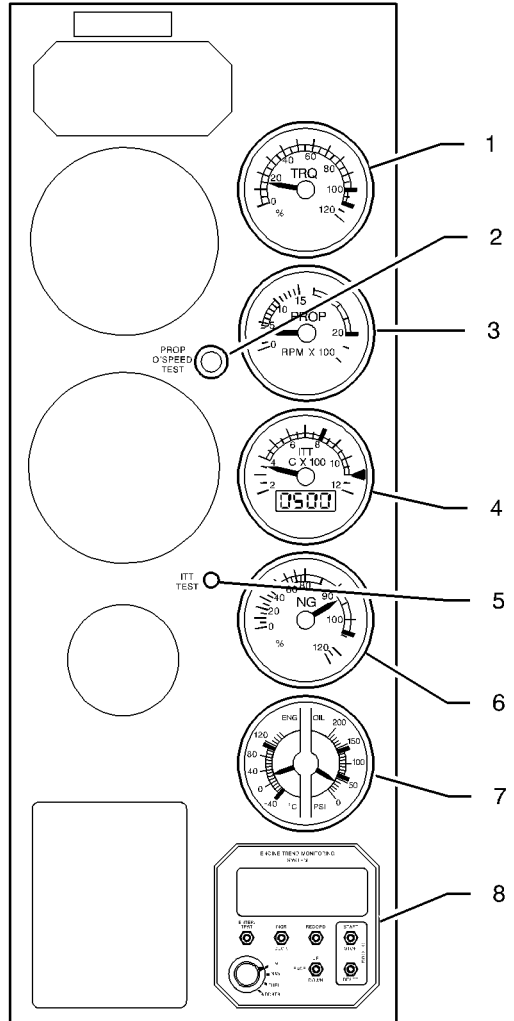
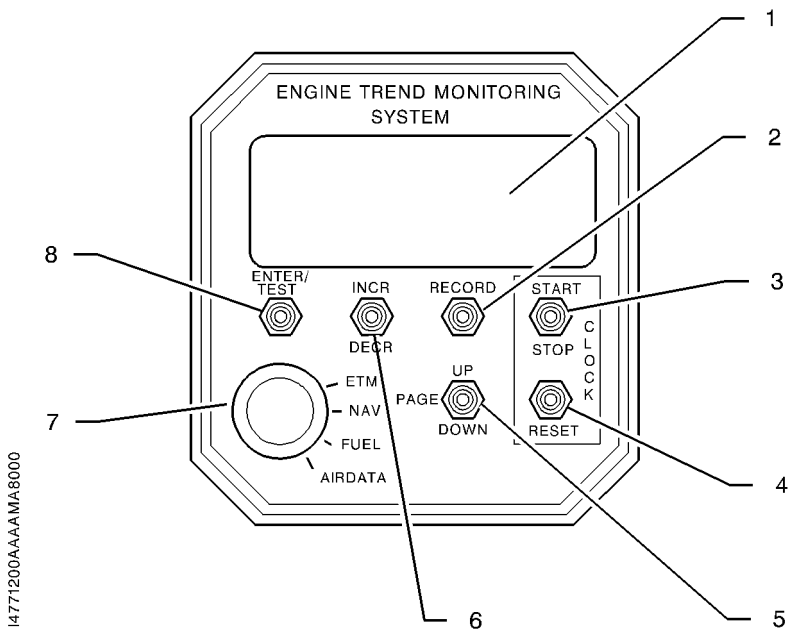

Figure 7.6.3 - ENGINE INSTRUMENTS

- 1 - DISPLAY
The window display of the ETM. It contains two lines, with 12 characters per line.
- 2 - RECORD BUTTON
This button is used to manually generate an output report
- 3 - STOPWATCH START / STOP SWITCH
When the stopwatch is activated, this switch starts and stops it
- 4 - STOPWATCH RESET BUTTON
Press this button to activate the stopwatch. Resets the stopwatch once it has been stopped
- 5 - PAGE UP / DOWN SWITCH
Used for scrolling through the pages of each file
- 6 - INCREMENT / DECREMENT SWITCH
This switch is used to scroll through subpages and increment or decrement an input value such as gross weight or fuel added
- 7 - ROTARY SWITCH
Selects from four files : ETM, NAV, FUEL, AIRDATA
- 8 - ENTER / TEST BUTTON
Used to activate the self test

Figure 7.6.4 (1/2) - ETM INDICATOR/COMPUTER



14771200AAAAMA8000

Figure 7.6.4 (2/2) - ETM INDICATOR/COMPUTER

ENGINE LUBRICATION

Engine oil is in a tank incorporated into the power plant. It ensures lubrication and engine cooling. A cooler located on left side in engine compartment maintains oil temperature within limits. Oil flow into the cooler is metered by a thermostatic valve. Engine oil also supplies propeller governor and engine torque meter.

Lubrication system content, cooler included, is 12.7 quarts (12 litres). A graduated dipstick allows checking oil quantity in system. A visual oil sight glass, located on engine left side, allows a rapid checking of oil level.

NOTE :

For checking and oil filling-up, refer to Section 8.

ENGINE STARTING (Figure 7.6.5)

Ignition function

Ignition system consists of an ignition unit and two spark igniter plugs in power plant, a three-position "IGNITION" switch "OFF - AUTO - ON" located on "ENGINE START" panel at upper panel and "IGNITION" warning light located on advisory panel.

Ignition unit supplies, from 28-Volt source, high voltage current necessary to spark igniter plugs. When "IGNITION" switch is positioned to "AUTO", ignition unit supply is ensured as long as "STARTER" switch located on left side of "IGNITION" switch is maintained "ON" : this is normal procedure for ground starting or flight air start with starter.

"ON" position for "IGNITION" switch is used in case of flight air start without starter. In this configuration, ignition unit is supplied permanently. In any case, "IGNITION" warning light illuminates as long as ignition unit is supplied.

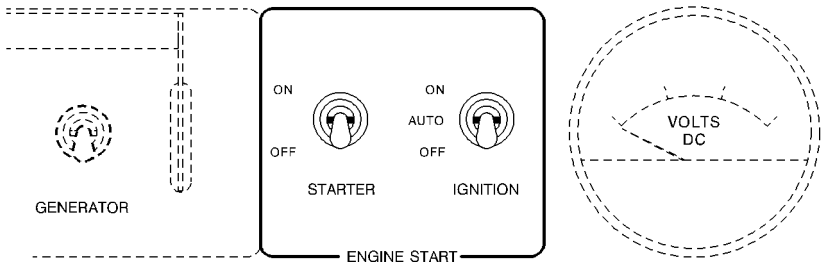
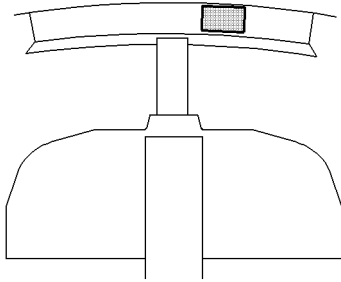

14240000AAAEMA8000

Figure 7.6.5 - ENGINE STARTING

Starter function

Starting system consists of "STARTER" switch located on "ENGINE START" panel, starter generator, "STARTER" warning light in advisory panel and ignition circuit (Refer to Paragraph "Ignition function").

Starting procedure is manual. Setting "STARTER" switch to "ON" connects the starter generator which drives power plant . "STARTER" warning light illuminates indicating that the starter generator is operating.

WARNING

ENGINE STARTING MUST BE PERFORMED BY QUALIFIED PERSONNEL AND BY FOLLOWING PROCEDURES AND PARAMETERS DESCRIBED IN SECTION 4 "NORMAL PROCEDURES"

ENGINE AIR INLET

Engine air inlet is located at front lower section of engine cowling. Air inlet port is protected against icing by a hot air flux provided by engine. Air is driven throughout a duct in engine casing before entering engine through a protective screen. An inertial separator system inside the air duct protects the engine from ingesting dense particles (water, ice, fine gravels, sand).

Separator consists of two movable vanes. During normal operation, air is channelled directly towards engine air inlet. To separate particles suspended in the air, vanes are positioned to force engine induction air to execute a sharp turn : under the effect of centrifugal force denser particles separate from the air and are discharged overboard through two apertures located under engine cowling.

Operation of inertial separator vanes is electrically controlled by "INERT SEP" inverter located on "DE-ICE SYSTEM" panel. When inverter is set to ON, an electric actuator activates vanes ; "INERT SEP" warning light on advisory panel illuminates when vanes have reached their maximum deflection and remains illuminated as long as switch remains ON. Full deflection takes about 30 seconds.

EXHAUST SYSTEM

Exhaust gases are evacuated through exhaust stubs located on sides of engine cowlings.

ENGINE ACCESSORIES

All engine driven accessories [except power turbine tacho-generator (Np) and propeller governor] are installed on accessory gearbox located rearwards of engine.

Oil pump

Oil pump is a self-controlled gear pump located at the bottom of oil casing.

Fuel high pressure pump (HP)

Fuel high pressure pump is installed on accessory gearbox. It supplies fuel nozzles, flow being controlled by fuel regulator (FCU). Fuel provided by engine driven main pump (mechanical) enters high pressure pump through a filter, then it is discharged under pressure into fuel regulator (FCU) through a second filter. In case of contamination of this second filter, a by-pass valve allows fuel to go directly from high pressure pump to the regulator.

Compressor turbine tacho-generator (Ng)

Compressor turbine tacho-generator (Ng) is attached on accessory gearbox. It supplies a voltage which feeds gas generator speed indicator.

Power turbine tacho-generator (Np)

Power turbine tacho-generator is attached on the right side of the reduction gearbox. It supplies a voltage which feeds propeller speed indicator.

Torque transmitter

Torque transmitter is attached on the torque limiter, it measures torque produced by the power turbine by comparing oil pressures (reduction gear and power turbine) and converts pressure difference into a voltage which is applied to torquemeter.

Propeller overspeed limiter

Propeller overspeed limiter is installed on left side of the reduction gear box. It prevents a propeller overspeed in case of main propeller governor failure.

Propeller overspeed limiter is equipped with a test solenoïd which allows performing ground tests by arming limiter under normal overspeed power.

"PROP O'SPEED TEST" propeller test push-button (Figure 7.6.3) of overspeed limiter is located on instrument panel near propeller speed indicator.

Torque limiter

Torque limiter is located on right side of the reduction gear box. It is rated to limit engine torque to 110 %.

PROPELLER

Airplane is equipped with an all-metal, four-bladed, constant-speed and full-feathering propeller.

Regulation

Propeller governor located on engine maintains rotation speed selected by pilot with propeller governor lever. Regulation is obtained through propeller blade pitch variation : counterweights drive propeller blades toward high pitch (low RPM) whereas oil pressure delivered by governor drives back blades toward low pitch (high RPM).

Propeller governor allows feathering either by voluntary pilot action via the propeller governor lever or automatically in case of engine failure or shutdown.

Propeller reverse pitch allows reduced taxiing speed or landing roll. Change from idle to reverse position is performed with power lever (Refer to Paragraph "ENGINE CONTROLS").

Propeller overspeed regulator tests (Figure 7.6.3)

"PROP O'SPEED TEST" push-button located on instrument panel near propeller speed indicator is used on ground to check proper operation of propeller overspeed regulator. This push-button activates a solenoid, attached on propeller overspeed regulator, which limits propeller rotation speed when power lever is positioned forwards.

INTENTIONALLY LEFT BLANK

7.7 - FUEL SYSTEM (Figure 7.7.1)

The fuel system comprises fuel tanks, fuel unit, selectors (manual and automatic), electric and mechanical boost pumps, engine fuel system, gaging installation, monitoring installation and drains.

FUEL TANKS

Fuel tanks are formed by sealed casings in each wing. Each fuel tank comprises a filling port located at the end of wing upper surface, two drain valves located at the lower surface (one near main landing gear, at trailing edge side, the second one near wing root side, at leading edge), a vent valve located on the lower surface, a suction strainer and three level gages.

FUEL UNIT

The fuel unit combines shut-off valve, tank selector and filter functions. It is connected to the manual selector through a mechanical control. The fuel filter is located in a bowl at the lower part of the unit. It is fitted with a by-pass valve, a clogging indicator and a drain valve.

TANK MANUAL SELECTOR (Figure 7.7.2)

The tank manual selector is located on the pedestal rear face. It allows selecting the tank ("R" or "L") to be used and setting unit to "OFF". To change from "L" position to "OFF" position, turn the selector clockwise ("L" → "R" → "OFF") ; change from "R" position to "OFF" position requires a voluntary action from the pilot (pull and turn). The "pull and turn" maneuver prevents involuntary operation. When the unit is set to "OFF", the "FUEL OFF" warning light on advisory panel remains illuminated.

- 1) Flow divider
- 2) Flowmeter
- 3) Collector tank
- 4) Fuel regulator
- 5) High pressure pump (HP)
- 6) Oil to fuel heater
- 7) Low pressure switch
- 8) Pressure transmitter
- 9) Fuel jet
- 10) Main mechanical boost pump
- 11) Electric boost pump
- 12) Fuel filter
- 13) Filter clogging by-pass valve
- 14) Filter clogging indicator
- 15) Fuel unit
- 16) Filter drain
- 17) Fuel return pipe
- 18) Filling port
- 19) NACA scoop
- 20) Tank vent valve
- 21) Fuel level gages
- 22) Tank drain valve
- 23) Check-valve
- 24) Low level detector
- 25) Suction strainer
- 26) Fuel pressure indicator
- 27) Fuel gage indicator
- 28) Sequencer
- 29) Advisory panel
- 30) ETM indicator/computer

Figure 7.7.1 (1/2) - FUEL SYSTEM

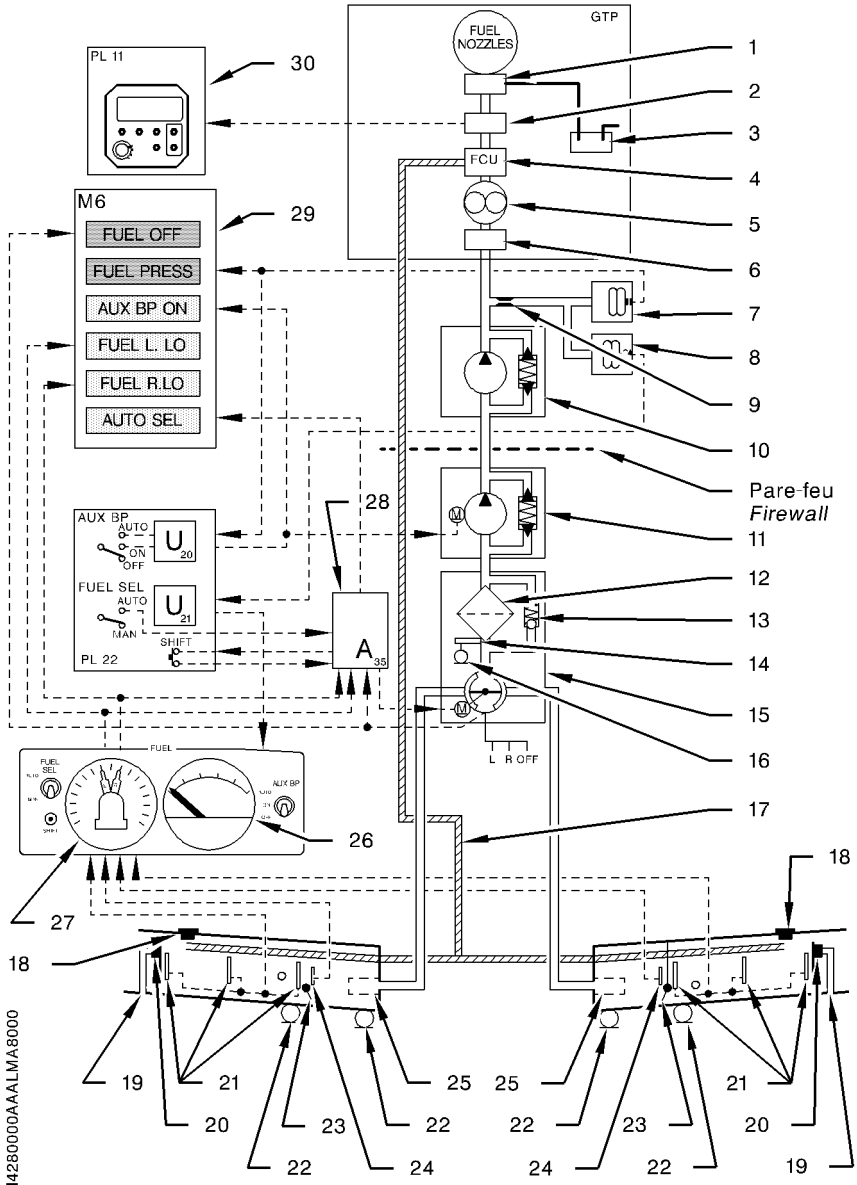

14280000AAALMA8000

Figure 7.7.1 (2/2) - FUEL SYSTEM

AUTOMATIC TANK SELECTOR (Figures 7.7.2 and 7.7.3)

Automatic tank selection allows, without pilot's intervention, feeding the engine from one tank to the other in predetermined sequences. These sequences depend on airplane configuration (ground, in-flight, fuel low level warning lights illuminated).

Automatic tank selection system comprises an electronic box (sequencer), an actuator attached on fuel unit, "FUEL SEL" two-position selector ("AUTO", "MAN") and "SHIFT" knob located on "FUEL" panel as well as "AUTO SEL" warning light located on advisory panel.

To operate the automatic selector, set "FUEL SEL" switch to "AUTO" position and manual selector to "R" or "L".

Selector operation

When the system is operated, "AUTO SEL" warning light goes out ; the sequencer chooses a tank ("R" or "L") and through the actuator, positions the fuel unit selector on the selected tank. The sequencer controls the time during which the selected tank will operate. This time varies, depending on airplane conditions.

Airplane on ground : tank is changed every minute and 15 seconds.

Pre-MOD70-402-28

Airplane in flight : tank is changed every ten minutes, as long as "FUEL L. LO" or "FUEL R. LO" low level warning light is not illuminated. When the first low level warning light illuminates, the sequencer immediately selects the other tank. The selected tank will operate until the second low level warning light illuminates. When both low level warning lights are illuminated, the sequencer changes tanks every minute and 15 seconds.

Post-MOD70-402-28

Airplane in flight : tank is changed every five minutes, as long as "FUEL L. LO" or "FUEL R. LO" low level warning light is not illuminated. When the first low level warning light illuminates, the sequencer immediately selects the other tank. The selected tank will operate until the second low level warning light illuminates. When both low level warning lights are illuminated, the sequencer changes tanks every minute and 15 seconds.

■ All

NOTE :

The manual selector is driven by the fuel unit and is positioned on "R" or "L" mark corresponding to the tank selected by the sequencer. Therefore, the pilot continuously knows the tank which is operating.

Test for system proper operation

"SHIFT" push-knob allows the pilot to test system proper operation anytime.

When the system operates, the fuel tank is changed when "SHIFT" push-knob is pressed once.

If airplane is on ground or in flight, low level warning lights not illuminated, the new selected tank remains operating and a new sequence is initiated.

NOTE :

This procedure allows the pilot to preferably choose the tank from which he wants to take fuel.

In all cases, proper system operation is indicated by rotation of the manual selector.

Setting "FUEL SEL" switch to "MAN" position or setting manual selector to "OFF" position leads to system de-activating and illumination of "AUTO SEL" warning light on advisory panel. "AUTO SEL" warning light also illuminates when order given by the sequencer has not been executed after 12 seconds.

ELECTRIC BOOST PUMP ("AUX BP")

Electric boost pump is an auxiliary pump located between fuel unit and main mechanical boost pump. It is controlled through "AUX BP" switch located on "FUEL" panel. This switch allows stopping or selecting the two pump operating modes :

- when set to "ON", electric boost pump operates permanently
- when set to "AUTO", electric boost pump is automatically operated in case of fuel pressure drop at the mechanical boost pump outlet.

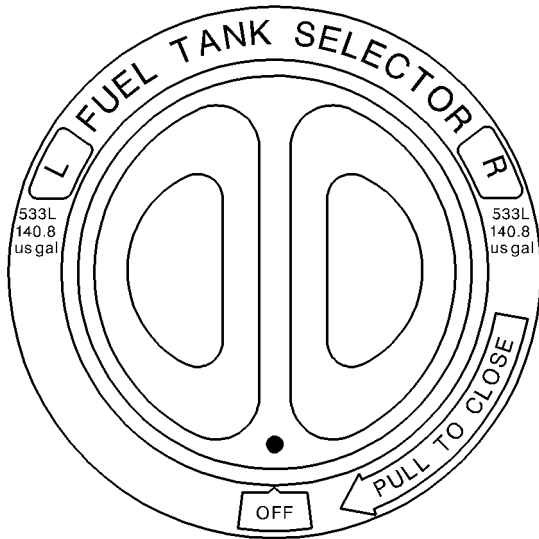
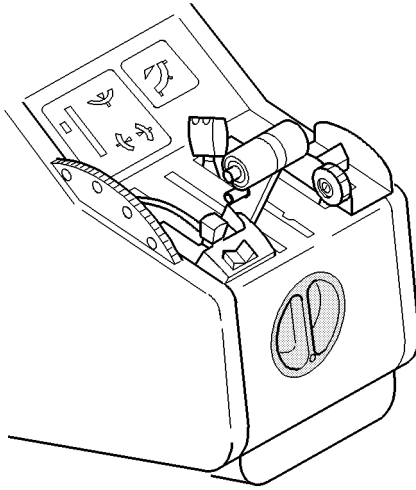

14282002AAAAGIMA8001

Figure 7.7.2 - MANUAL SELECTOR OF FUEL TANKS

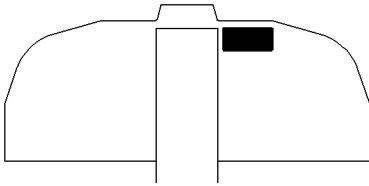

Indicateur quantité
réservoir gauche
*L.H. fuel quantity
indicator*

Indicateur quantité réservoir droit
*R.H. fuel quantity
indicator*

Indicateur pression
carburant
*Fuel pressure
indicator*

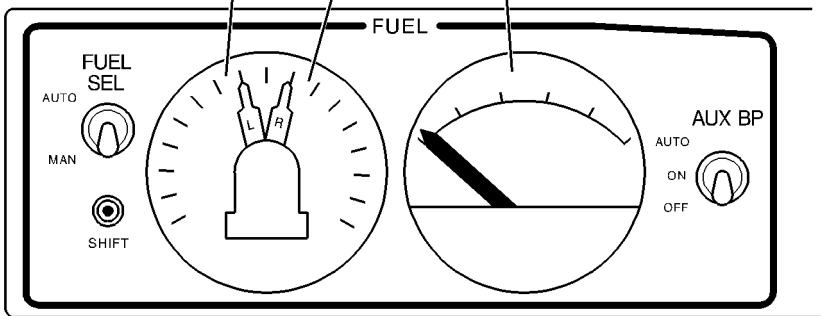

I4280001AAAA MA8100

Figure 7.7.3 - FUEL CONTROL PANEL

MAIN MECHANICAL BOOST PUMP

The mechanical boost pump is attached to accessory gearbox and supplies fuel necessary for engine operation.

ENGINE FUEL SYSTEM

The engine fuel system consists of a fuel regulator, pumps, filters, a fuel divider and fuel nozzles. The system provides the fuel flow necessary to satisfy the engine power and rating needs.

The fuel coming from airplane system goes through a heater which is automatically controlled by a thermostatic valve.

FUEL GAGING INSTALLATION

Fuel gaging installation is a capacitive type and consists of a dual indicator graduated in us gallons (Figure 7.7.3) and fuel level gages. Three fuel level gages are installed in each tank. The wing root side fuel level gage is equipped with a low level detector which leads to "FUEL L. LO" or "FUEL R. LO" warning light illumination when usable fuel quantity remaining in the concerned fuel tank is under about 9.1 us gal (34.6 Litres).

ETM INDICATOR/COMPUTER

Located at the lower part of L.H. instrument panel, the indicator/computer helps the pilot to control fuel during one or several flights. Indicator/computer operation is described in manufacturer technical data.

CAUTION

**THE INDICATOR/COMPUTER NEITHER REPLACES FUEL GAGES
NOR FUEL PRESSURE INDICATOR. THESE INSTRUMENTS SHALL
BE CONSULTED FIRST FOR FLIGHT MANAGEMENT.**

FUEL MONITORING INSTALLATION (Figure 7.7.3)

Monitoring installation comprises pressure indicator and warning lights grouped on advisory panel.

Pressure indicator is attached on "FUEL" panel ; it indicates fuel pressure at main booster pump outlet.

Indications provided by illumination of warning lights on advisory panel :

- "FUEL OFF" : Fuel tank selector set to "OFF"
- "FUEL PRESS" : Fuel pressure at mechanic pump outlet under 10 psi (± 2 psi)
- "AUX BP ON" : Electric boost pump operating
- "FUEL L. LO" : Fuel quantity in L.H. fuel tank under about 9.1 us gal (34.6 Litres) of usable fuel
- "FUEL R. LO" : Fuel quantity in R.H. fuel tank under about 9.1 us gal (34.6 Litres) of usable fuel
- "AUTO SEL" : Sequencer inactive or operating defect

FUEL SYSTEM DRAINING AND CLOGGING INDICATOR (Figure 7.7.4)

The fuel system comprises five drain points, a drain on the filter bowl, two drain valves on each tank, located on wing lower surface, one at wing root and the other past main landing gear well.

These drains allow draining water or sediments contained in fuel.

Fuel tank drain valves are provided with a slot which allows opening them with a screwdriver.

Fuel system draining shall be performed prior to the first flight of the day and after each tank refueling, using a sampler to pick off fuel at the two drain valves of each tank and at the filter vent valve.

A red filter bypass flag on the fuel unit and visible from outside, when an inspection door located on L.H. side under front baggage compartment is open, indicates filter clogging. A push-button, adjacent to the inspection door, controls the illumination of a light provided to improve visibility of the clogging indicator. This indicator shall be observed during preflight inspection.

NOTE :

When filter gets clogged in flight, the filter is by-passed in order not to deprive power plant from fuel. The power plant is then supplied with non-filtered fuel.

- | | |
|------------------------|-----------------|
| 1) Lighting switch | 5) Filter drain |
| 2) Mirror door | 6) Tank drain |
| 3) Clogging indicator | 7) Drain bowl |
| 4) Central access door | |

Figure 7.7.4 (1/2) - FUEL SYSTEM DRAINING POINTS AND CLOGGING INDICATOR

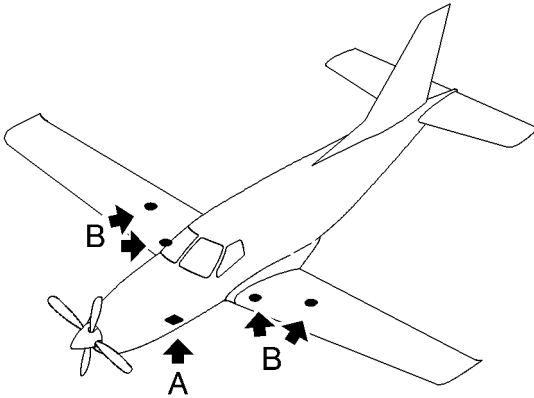

I4281001AAA BMA8102

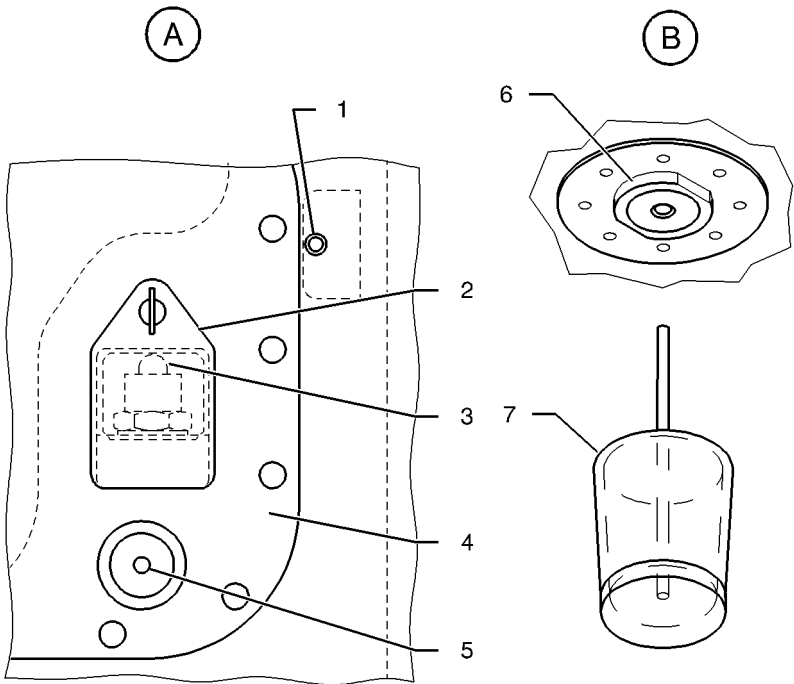

Figure 7.7.4 (2/2) - FUEL SYSTEM DRAINING POINTS AND CLOGGING INDICATOR

INTENTIONALLY LEFT BLANK

7.8 - ELECTRICAL SYSTEM (Figures 7.8.1 and 7.8.5)

The airplane is fitted with a direct-current electrical system rated to 28 volts with negative pole at ground.

Airplane mains supply is obtained from various power supplies :

- an engine driven starter generator
- a stand-by generator driven by the engine through a belt
- a battery located in engine compartment
- a ground power receptacle located in engine compartment, on L.H. side. It is accessible from outside through a door.

Connection relays, main bus bar, generator regulation and protection systems and control logic systems are grouped in electrical power center attached to front baggage compartment upper section.

Indicating and checking warning lights are grouped on advisory panel.

STARTER GENERATOR

The starter generator is the main electrical power source. It only performs its generator function when starting sequence is completed.

Generator connection with main bus bar is controlled through "GENERATOR" selector set to "MAIN" position. It will be effective when connection conditions are met. Generator connection is indicated by "MAIN GEN" warning light extinguishing.

STAND-BY GENERATOR

Stand-by generator supplies a 28-volt stand-by direct current which may be used in case of main generator failure.

Generator connection with main bus bar is controlled through "GENERATOR" selector set to "ST-BY", it will be effective when connection conditions are met.

NOTE :

In order to prevent possible errors during flight, access to "ST-BY" position requires a double action from the pilot (pull to unlock).

BATTERY

The battery provides the power required for starting when no ground power unit is available and is a power supply source when engine driven generators are stopped.

The battery is always connected to "BAT BUS" bus bar except when CRASH lever is pulled down.

Battery connection to main bus bar is controlled through "SOURCE" selector set to "BAT" position.

"BAT OFF" warning light is illuminated when battery is isolated from the main bus and when main bus is supplied through another source.

GROUND POWER RECEPTACLE

The ground power receptacle allows connection to a ground power unit. Ground power receptacle connection with main bus bar is controlled through "SOURCE" selector when set to "GPU" position, it will be effective when connection conditions are met.

NOTE :

Ground power receptacle has priority on other generators.

Ground power receptacle door opening is indicated by "GPU" warning light illumination.

INTENTIONALLY LEFT BLANK

DISTRIBUTION

Airplane electrical systems are connected to "BUS" bars and protected by circuit breakers located on L.H. side panel, near the pilot (See Figure 7.8.3) or on R.H. side panel, if "pilot" door installed (See Figure 7.8.3A). In case of overload of a system, the circuit breaker triggers and switches the system off. Allow it to cool for about three minutes, then the circuit breaker may be reengaged (pressed down). Some systems are equipped with "pull off" type circuit breakers which allow the pilot to insulate, if necessary, the corresponding equipment.

"BUS 1", "BUS 2" and "BUS 3" bus bars are directly connected to main bus bar and protected by fuses located in electrical power center.

"ESS 1" and "ESS 2" essential bus bars are connected to main bus bar through "ESS BUS TIE" selector set to "NORM" position. "ESS BUS TIE" selector is attached to circuit breaker panel, "NORM" position is protected and locked by a cover. Common power supply to both essential bus bars is protected by a fuse, each bar being individually protected by a circuit breaker.

"BUS BAT" bar is directly connected to the battery, it is protected by a fuse located in electrical power center.

NOTE :

The electrical distribution of bus bars is described in Figure 7.8.2.

EMERGENCY USE

With both generators de-activated in flight, it is still possible to use battery power to supply all airplane systems maintaining "SOURCE" selector on "BAT" position.

In order to save battery power, it is possible to shed the charges which are not essential for flight safety, for that set :

- "ESS BUS TIE" selector to "EMER" position

In this configuration, only "ESS 1", "ESS 2" and "BAT BUS" bars are supplied.

NOTE :

Supplying "BUS 1", "BUS 2" and "BUS 3" bars is always possible, resetting temporarily "ESS BUS TIE" selector to "NORM" position.

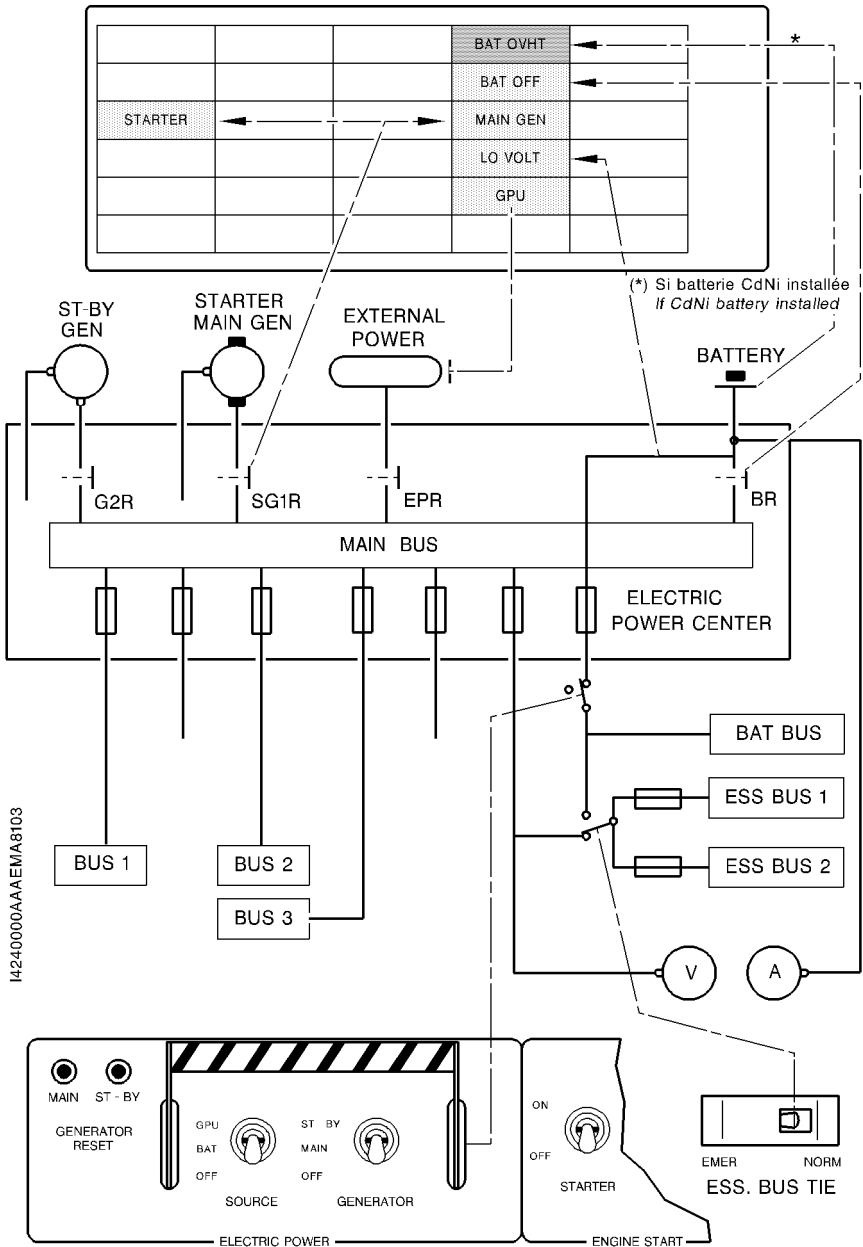

Figure 7.8.1 - ELECTRICAL DIAGRAM

14246000AAAACMA8000

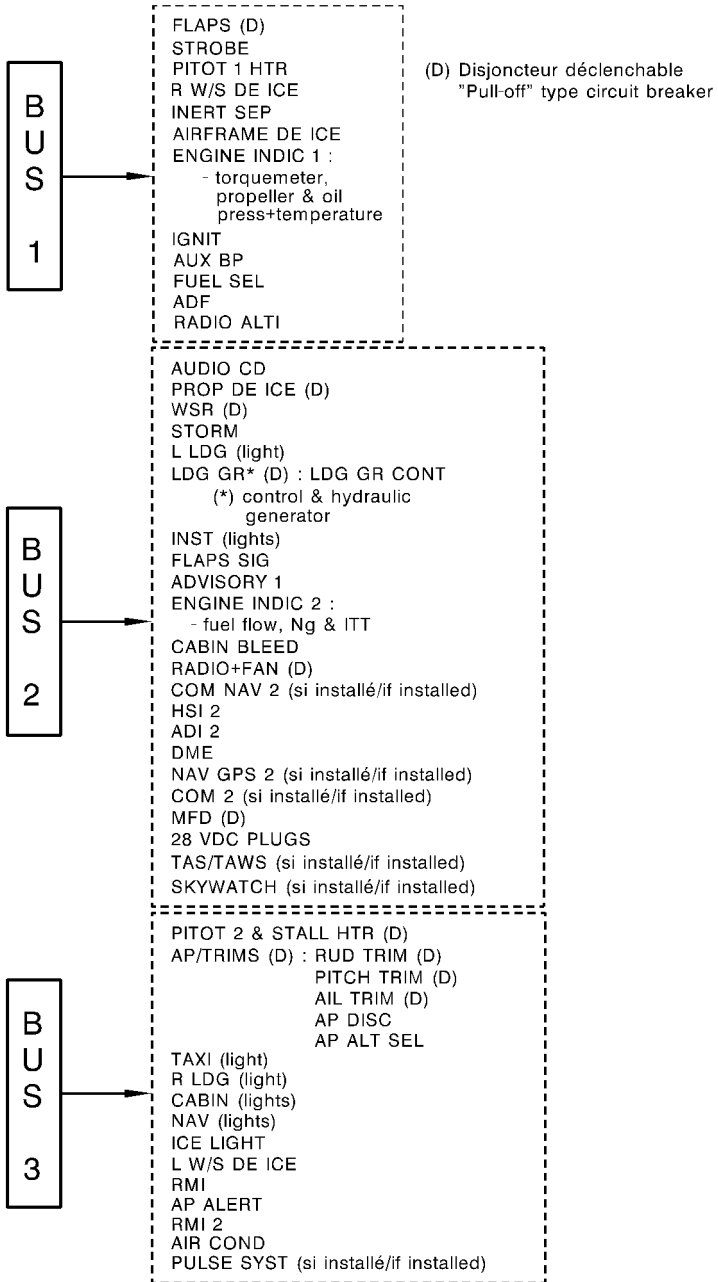
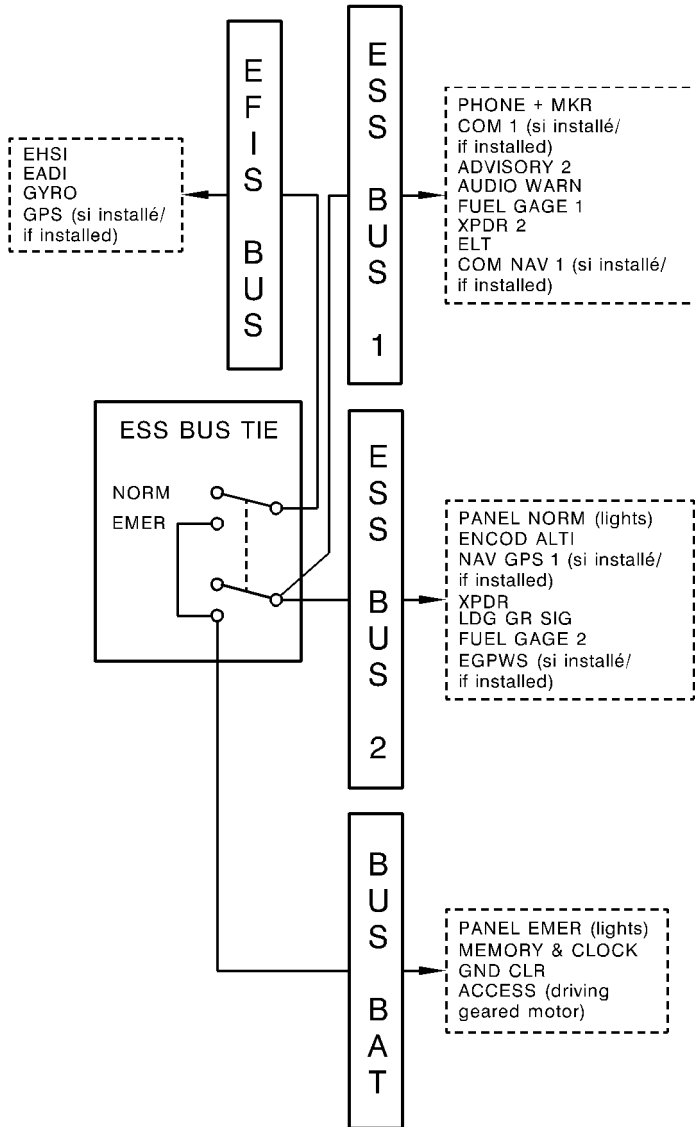

Figure 7.8.2 (1/2) - ELECTRICAL DISTRIBUTION OF BUS BARS



14246000AAACMA8100



Figure 7.8.2 (2/2) - ELECTRICAL DISTRIBUTION OF BUS BARS

AP / TRIMS	AP & trims general protec.	FUEL GAGE 1	L.H gage protection
RUD TRIM	Rudder trim protection	FUEL GAGE 2	R.H gage protection
AIL TRIM	Aileron trim protection	FUEL SEL	Timer protection
PITCH TRIM	Pitch trim protection	AUX BP	Fuel pump protection
FLAPS	Flaps protection	ENGINE INDIC 1	Power plant cont. protec. : Oil temp. & pres., torque, propeller
LDG GR	Landing gear general protec.	ENGINE INDIC 2	Power plant cont. protection : Ng, flowmeter & ITT
ESS BUS TIE	Essential bus NORM & EMER switch	IGNIT	Power plant ignit. protection
PITOT 1 HTR	Pitot 1 deicing protection	CABIN BLEED AIR COND	Cabin air bleed valve protec. Cabin ventilation and vapor cycle cooling system protec.
PITOT 2 & STALL HTR	Pitot 2 and stall warning deicing protection	MEMORY & CLOCK ACCESS	Stop watch and flowmeter protec. Cabin lightings & access door closing geared motor protec.
INERT SEP	Inertial separator protection	EHSI	EHSI protection
LW/S DE ICE	L.H. windshield deicing protection	EADI	EADI protection
RW/S DE ICE	R.H. windshield deicing protection	GYRO	EFIS static converter protection
PROP DE ICE	Propeller deicing protection	RMI	RMI 1 protection
AIRFRAME DE ICE	Empennage and wing leading edges deicing protection	ADI 2	ADI No. 2 protection
AUDIO CD	CD reader protection (if installed)	RMI 2	RMI 2 protection
FLAPS SIG	Flaps signalization protec.	HSI 2	HSI 2 protection
LDG GR CONT	Landing gear control protection	ELT	Emergency beacon protection
LDG GR SIG	Landing gear signalization protection	28VDC PLUGS	28 volts plugs protection
AP DISC	Trim and AP cont. protection	PHONE+MKR	Reception line and loudspeaker + MKR protection
AP ALERT	Trim and AP audio signalization protection	COM NAV 1	HONEYW. COM NAV 1 protec. (if installed)
AP ALT SEL	Altitude selector protection	NAV GPS 1	GARMIN NAV GPS 1 protec. (if installed)
ESS BUS 1	Essential bus 1 circuit protection	GND CLR	Ground communication protec.
ESS BUS 2	Essential bus 2 circuit protection	XPDR 2	Transponder 2 protection
ADVISORY 1	Visual warnings protection	COM NAV 2	HONEYW. COM NAV 2 protec. (if installed)
ADVISORY 2	Visual warnings protection	NAV GPS 2	GARMIN NAV GPS 2 protec. (if installed)
AUDIO WARN	Audio warnings protection	ENCOD ALTI	Encoding altimeter protection
L LDG	L.H. landing light protection	XPDR	Transponder 1 protection
TAXI	Taxi light protection	RADIO ALTI	RADIO ALTI protection
R LDG	R.H. landing light protection	RADIO + FAN	Radio ventilation + radio master protection
NAV	Navigation lights protection	ADF	ADF protection
STROBE	Strobe lights protection	DME	DME protection
ICE	L.H. wing leading edge light. and lighting test protection	TAS/TAWS	TAS/TAWS protec. (if installed)
LIGHT PULSE	Pulse lite system (if installed) protection	STORM	Stormscope protection
SYST	Instruments lighting protec.	WSR	Weather radar protection
INSTR	Instruments lighting protec.	MFD	Multi-function display protec.
PANEL NORM	Instrument panel normal lighting protection	GPS	HONEY. GPS protec. (if insta.)
PANEL EMER	Instrument panel emergency lighting protection	COM 1	VHF 1 protection (if installed)
CABIN	Passenger's reading lamps protection	COM 2	VHF 2 & radio protection (if installed)

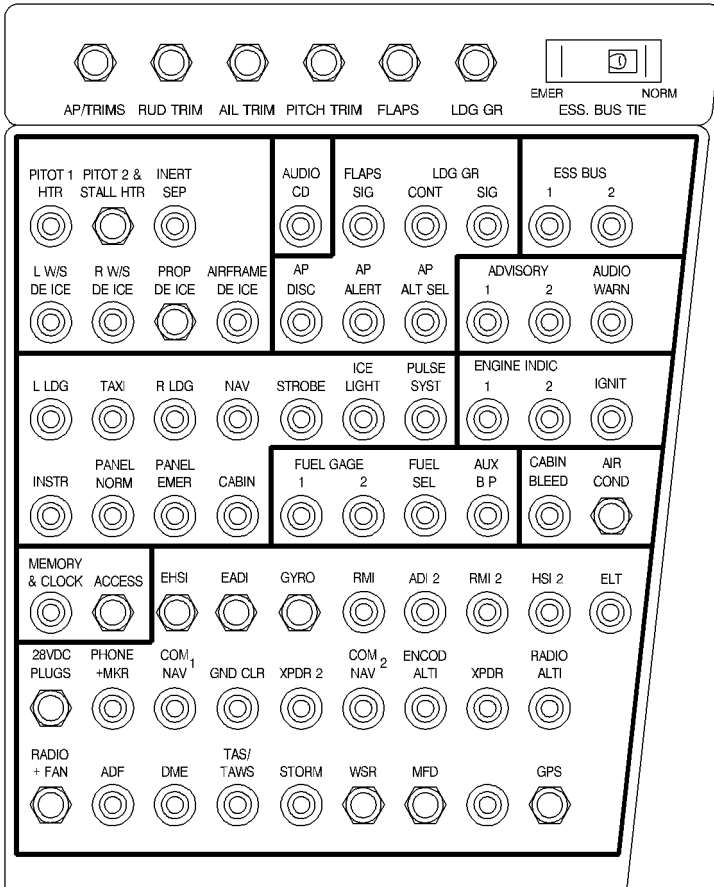
Figure 7.8.3 (1/3) - CIRCUIT BREAKER PANEL (Typical arrangement)



I4255004AAAGMA18103



-  Disjoncteur déclenchable
"PULL-OFF" type circuit breaker
-  Disjoncteur non déclenchable
Circuit breaker which cannot be pulled off

NOTE :
If an additional equipment is installed, its circuit breaker is installed on a free location.

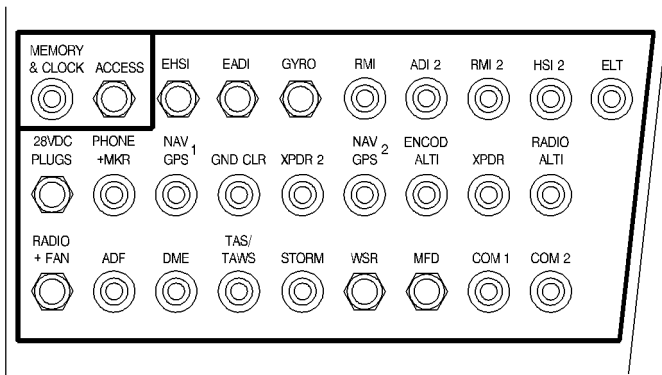
Figure 7.8.3 (2/3) - CIRCUIT BREAKER PANEL
("HONEYWELL" typical arrangement)



I4255004AAAGMA18203

-  Disjoncteur déclenchable
"PULL-OFF" type circuit breaker
-  Disjoncteur non déclenchable
Circuit breaker which cannot be pulled off

NOTE :

If an additional equipment is installed, its circuit breaker is installed on a free location.

Figure 7.8.3 (3/3) - CIRCUIT BREAKER PANEL
("GARMIN" typical arrangement)



INTENTIONALLY LEFT BLANK

ESS BUS TIE	Essential bus NORM & EMER switch	PULSE SYST	Pulse lite system (if installed) protection
LDG GR FLAPS	LDG general protection Flaps protection	ICE LIGHT	L.H. wing leading edge lighting and lighting test protection
PITCH TRIM	Pitch trim protection	STROBE	Strobe lights protection
AIL TRIM	Aileron trim protection	L LDG TAXI	L.H. landing light protection Taxi light protection
RUD TRIM	Rudder trim protection	R LDG NAV	R.H. landing light protection Navigation lights protection
AP / TRIMS	AP & trims general protec.	INSTR	Instruments lighting protec.
ESS BUS 1	Essential bus 1 circuit protection	PANEL NORM	Instrument panel normal lighting protection
ESS BUS 2	Essential bus 2 circuit protection	PANEL EMER	Instrument panel emergency lighting protection
ADVISORY 1	Visual warnings protection	CABIN	Passenger's reading lamps protection
ADVISORY 2	Visual warnings protection	ACCESS	Cabin lightings & access door closing geared motor protec.
AUDIO WARN	Audio warnings protection	MEMORY & CLOCK	Stop watch and flowmeter protec.
FLAPS SIG	Flaps signalization protec.	ELT	Emergency beacon protection
LDG GR CONT	Landing gear control protection	EHSI	EHSI protection
LDG GR SIG	Landing gear signalization protection	EADI	EADI protection
AP DISC	Trim and AP cont. protection	GYRO	EFIS static converter protection
AP ALERT	Trim and AP audio signalization protection	RMI	RMI 1 protection
AP ALT SEL	Altitude selector protection	ADI 2	ADI No. 2 protection
AUDIO CD	CD reader protection (if installed)	RMI 2	RMI 2 protection
PITOT 1 HTR	Pitot 1 deicing protection	HSI 2	HSI 2 protection
PITOT 2 & STALL HTR	Pitot 2 and stall warning deicing protection	RADIO ALTI	RADIO ALTI protection
INERT SEP	Inertial separator protection	28VDC PLUGS	28 volts plugs protection
LW/S DE ICE	L.H. windshield deicing protection	PHONE+MKR	Reception line and loudspeaker + MKR protection
RW/S DE ICE	R.H. windshield deicing protection	COM NAV 1	HONEYW. COM NAV 1 protec. (if installed)
PROP DE ICE	Propeller deicing protection	NAV GPS 1	GARMIN NAV GPS 1 protec. (if installed)
AIRFRAME DE ICE	Empennage and wing leading edges deicing protection	GND CLR	Ground communication protec.
ENGINE INDIC 1	Power plant contr. protec. : Oil T° & pres., torque, propel.	XPDR 2	Transponder 2 protection
ENGINE INDIC 2	Power plant cont. protec. : Ng, flowmeter & ITT	COM NAV 2	HONEYW. COM NAV 2 protec. (if installed)
IGNIT	Power plant ignit. protection	NAV GPS 2	GARMIN NAV GPS 2 protec. (if installed)
CABIN BLEED AIR COND	Cabin air bleed valve protec. Cabin ventilat. and vapor cycle cooling system protec.	ENCOD ALTI	Encoding altimeter protection
FUEL GAGE 1	L.H gage protection	XPDR	Transponder 1 protection
FUEL GAGE 2	R.H gage protection	GPS	HONEYW. GPS protection (if installed)
FUEL SEL	Timer protection	COM 1	VHF 1 protection (if installed)
AUX BP	Fuel pump protection	COM 2	VHF 2 & radio (if insta.) protec.
		ADF	ADF protection
		DME	DME protection
		TAS/TAWS	TAS/TAWS (if installed) protec.
		STORM WSR	Stormscope protection Weather radar protection
		MFD	Multi-function display protection
		RADIO+ FAN	Radio ventilation + radio master protection

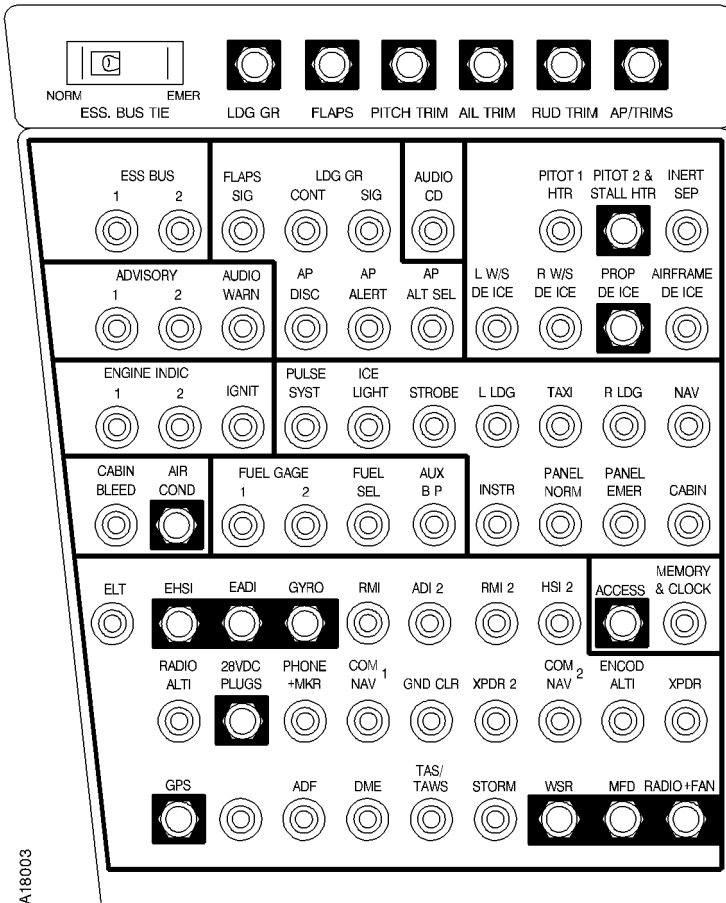
Figure 7.8.3A (1/3) - CIRCUIT BREAKER PANEL (Typical arrangement)



I4255004AAAGM/A18003

-  Disjoncteur déclenchable
"PULL-OFF" type circuit breaker
-  Disjoncteur non déclenchable
Circuit breaker which cannot be pulled off

NOTE :

If an additional equipment is installed, its circuit breaker is installed on a free location.

Figure 7.8.3A (2/3) - CIRCUIT BREAKER PANEL
("HONEYWELL" typical arrangement)

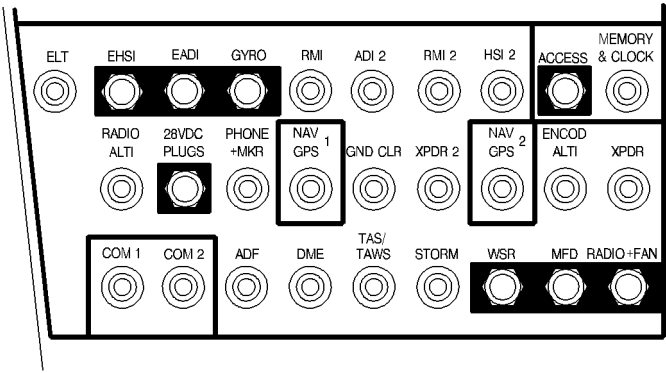

I4255004AAAGMA8303

- Disjoncteur déclenchable
"PULL-OFF" type circuit breaker
- Disjoncteur non déclenchable
Circuit breaker which cannot be pulled off

NOTE :
If an additional equipment is installed, its circuit breaker is installed on a free location.

Figure 7.8.3A (3/3) - CIRCUIT BREAKER PANEL
("GARMIN" typical arrangement)

INDICATING (Figure 7.8.4)

Electrical system indicating consists of a voltmeter and an ammeter located on the upper panel, as well as warning lights grouped on advisory panel.

The **voltmeter** indicates the voltage with generator connected to main bus bar. When the starter generator or stand-by generator are operating normally, the voltmeter needle will be in green sector.

The **ammeter**, graduated from - 200 to + 200 amperes, indicates the battery charge and discharge. The needle indicates a positive value when battery and starter generator (or stand-by generator) are connected to main bus bar.

Indications provided by warning light illumination are as follows :

- "BAT OVHT" : Overheat inside the battery (if Cadmium-Nickel battery installed)
- "BAT OFF" : Battery is not connected to main bus bar and the latter is supplied by another power source
- "MAIN GEN" : Starter generator is not connected to main bus bar
- "LO VOLT" : Battery voltage is below the minimum value and main bus bar is supplied
- "GPU" : Ground power receptacle access door is not closed

Moreover, the indicating system may be completed by a battery temperature indicator located on the R.H. lower part of the R.H. instrument panel. This indicator is connected to a probe installed on the battery. A "BAT TEMP TEST" push-button located near the indicator allows to test the illumination of the "BAT OVHT" warning light and to check simultaneously, on the indicator, the increase of the indicated temperature.

PROTECTION - SAFETY (Figure 7.8.5)

The electrical power center provides systems protection in case of :

- overvoltage coming from the starter generator, the stand-by generator or the ground power receptacle
- short-circuit in starter generator feeder
- starter generator undervoltage

In case of disconnection of starter generator or stand-by generator following a failure, it is possible to re-activate the system by pressing on "MAIN" or "ST-BY" knob of "GENERATOR RESET".

A **crash lever** located on upper panel center part allows isolating simultaneously "BUS BAT" bar and setting to "OFF", "SOURCE" and "GENERATOR" selectors when lowered. All bus bars are isolated from generators.

- 1) Ammeter
- 2) Voltmeter
- 3) General flashing red and amber warning lights
- 4) Electric system warning lights on the "ADVISORY PANEL"
- 5) Battery temperature indicator (if installed)
- 6) "BAT TEMP TEST" push-button (if installed)

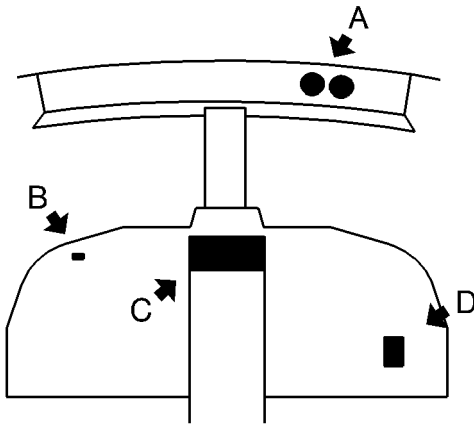

14251000AAA KMA8002

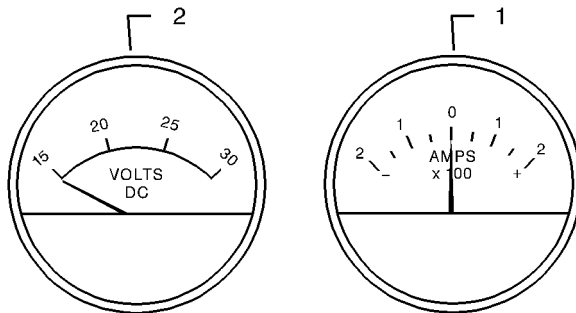
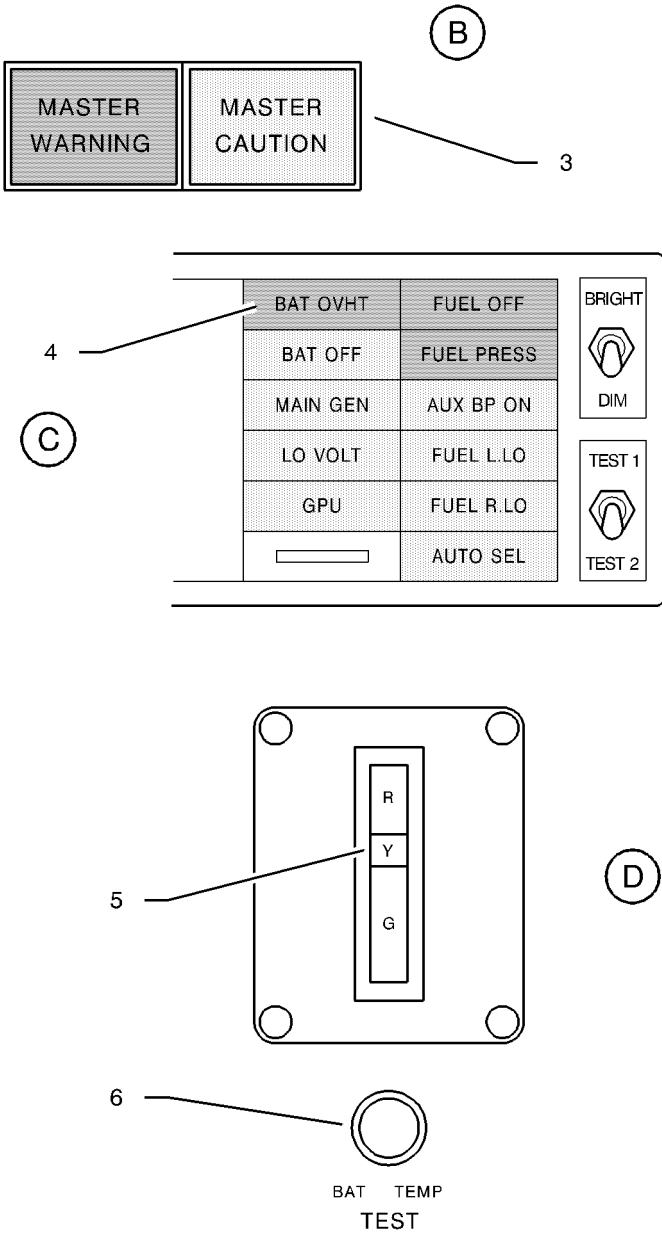
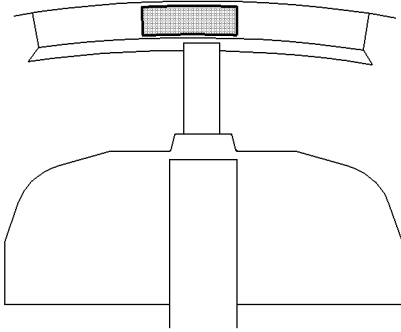

Figure 7.8.4 (1/2) - INDICATING



14315001AAABM/A8103

Figure 7.8.4 (2/2) - INDICATING



- 1) "MAIN" reset knob
- 2) "ST-BY" reset knob
- 3) Crash lever
- 4) "SOURCE" selector
- 5) "GENERATOR" selector

I424000AAA EIMA8200

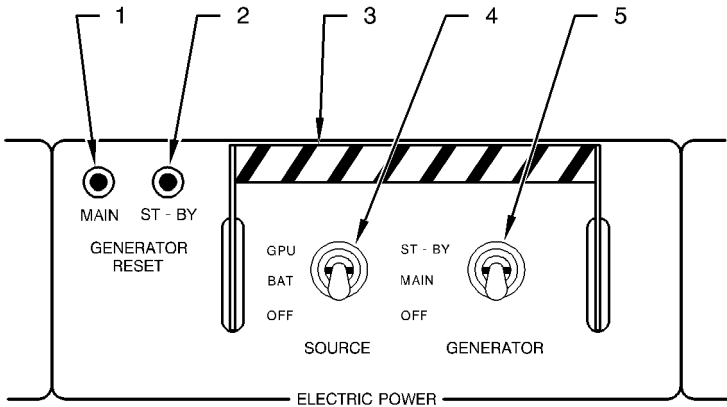

Figure 7.8.5 - ELECTRICAL CONTROL

EXTERIOR LIGHTING (Figure 7.8.6)

The airplane is equipped with two navigation lights, two strobe lights, two landing lights, a taxi light, a wing leading edge icing inspection light.

A "LTS TEST" test-knob located above lights switches allows checking proper operation of warning lights ; their brightness may be dimmed by main "DIM" switch on advisory panel.

Landing lights

Landing lights are located at each wing tip and located in leading edges. Lights illumination is controlled by "L. LDG" and "R. LDG" switches located on upper panel. A warning light is incorporated in each switch to indicate proper operation of used landing light.

The Pulse lite system (if installed) enables the pilot to control landing light flashing to be seen by the control tower or in heavy traffic areas.

Taxi light

The taxi light is attached to the nose gear, it is controlled by "TAXI" switch located on upper panel. A warning light is incorporated in this switch to indicate proper operation of used light.

Navigation lights and strobe lights

Navigation lights and strobe lights are installed on wing tips. They are controlled by "NAV" and "STROBE" switches located on upper panel.

NOTE :

By night, do not use anticollision lights in fog, clouds or mist as light beam reflexion may lead to dizziness and loss of sense of orientation.

Leading edge icing inspection light

The leading edge icing inspection light is installed on fuselage L.H. side, its beam illuminates the wing leading edge. It is controlled by the "ICE LIGHT" switch installed on "DE-ICE SYSTEM" panel (Figure 7.13.1).

FWD compartment light

The dome light of the FWD compartment has two positions :

- the first allows automatic illumination via the switch located in the upper section of the door frame,
- the second maintains the dome light permanently off regardless of the door position.

Fuel unit compartment light

The lighting of the fuel unit compartment allows improving the visibility of the clogging indicator by pressing the push-button located besides the inspection door.

- 1) L.H. landing light switch
- 2) Test knob (test light integrated to switches)
- 3) Taxi light switch
- 4) R.H. landing light switch
- 5) Navigation lights switch
- 6) Strobe lights switch
- 7) Pulse lite system switch (if installed)

Figure 7.8.6 (1/2) - EXTERNAL LIGHTING CONTROLS

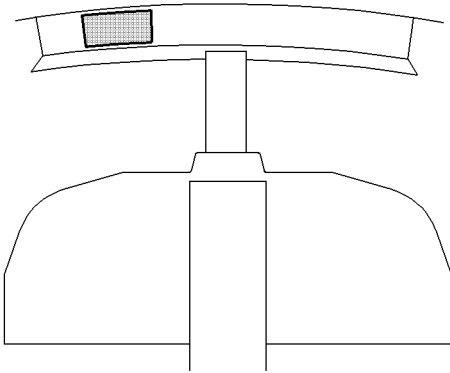

I4334000AAAAMAB100

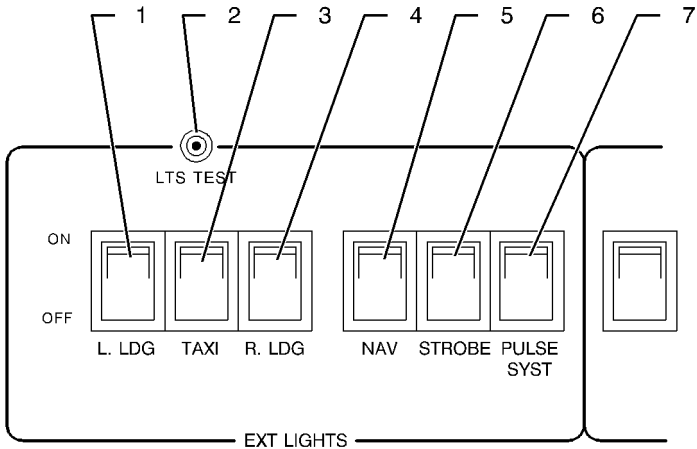

Figure 7.8.6 (2/2) - EXTERNAL LIGHTING CONTROLS

INTERIOR LIGHTING (Figure 7.8.7)

Interior lighting consists of access, cabin, instrument panel, instruments, baggage compartment and emergency lighting.

Access lighting

Access lighting consists of two floodlights located on the ceiling upholstery (one at the level of the access door, the other at the level of the storage cabinet) and the L.H. dome light of baggage compartment. "ACCESS" push-button on "INT LIGHTS" panel and the push-button located on access door rear frame control these 3 lights via a delayed breaker.

If the CRASH lever is down, access lighting is automatically cut out after 3 minutes.

If the CRASH lever is up, there is no access lighting automatic cut out.

Cabin lighting

Cabin lighting consists of two swiveling floodlights for front seats, six individual floodlights for rear passenger seats and the baggage compartment R.H. dome light. Each floodlight is controlled by a switch located on side upholstery strip. The floodlight above the table is controlled by two switches which are two-way switches type. The pilot can switch off the cabin floodlights and the baggage compartment dome light with the "CABIN" switch.

Instrument panel lighting

Instrument panel lighting is controlled by the "PANEL" rheostat located on "INT. LIGHTS" panel. This lighting consists of visor lighting and the two postlights located on the upper duct (forward of emergency floodlights).

Instruments and radio equipment lighting

The lighting, controlled by the "INSTR" rheostat located on "INT. LIGHTS" panel is integrated in instruments and radio equipment.

NOTE :

"PANEL" and "INSTR" rheostats control lighting operation and intensity. Clockwise rotation of control knob allows changing from "OFF" position to maximum lighting. Counterclockwise rotation reduces lighting to minimum brightness.

Emergency lighting

Emergency lighting consists of two swiveling floodlights located on the upper duct above front seats. It illuminates instrument panel assembly in case of visor lighting and / or instrument integrated lighting failure.

The rheostat located near R.H. floodlight controls emergency lighting operation and intensity. Forward rotation of control knob allows changing from "OFF" position to minimum lighting then increasing lighting to maximum brightness.

Map reading light illumination

The illumination of the map reading lights located on control wheels is controlled by the switch (rheostat) located on each light.

- 1) Instrument lighting switch (rheostat)
- 2) Instrument panel lighting switch (rheostat)
- 3) Cabin lighting switch (rear seats reading light)
- 4) Access door, baggage compartment and FWD dome light (delayed breaker) push-button
- 5) Emergency lighting switch (rheostat)

Figure 7.8.7 (1/2) - INTERNAL LIGHTING CONTROLS

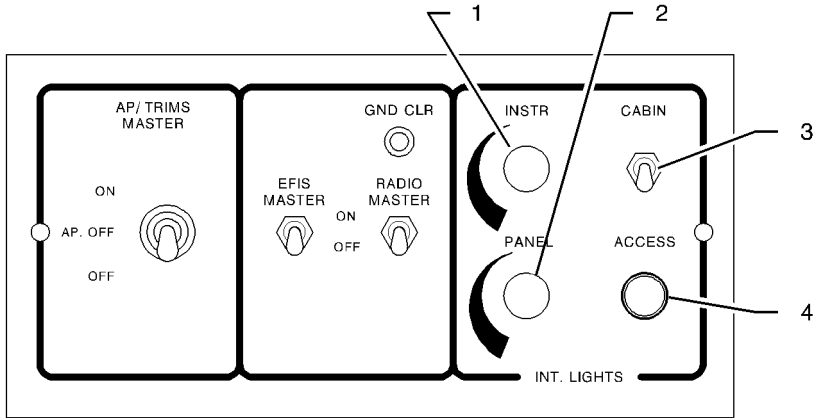
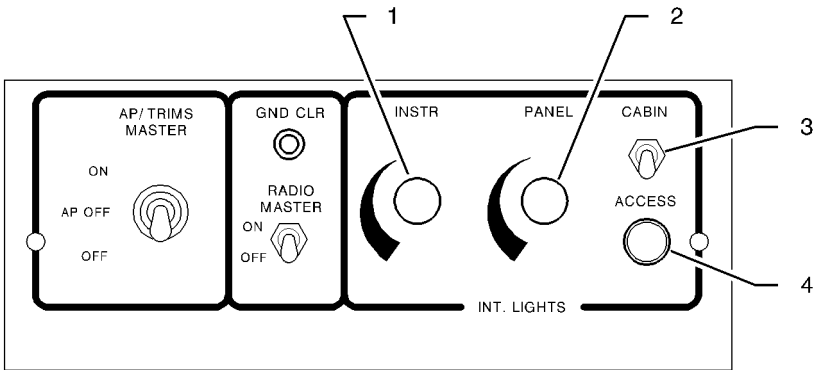
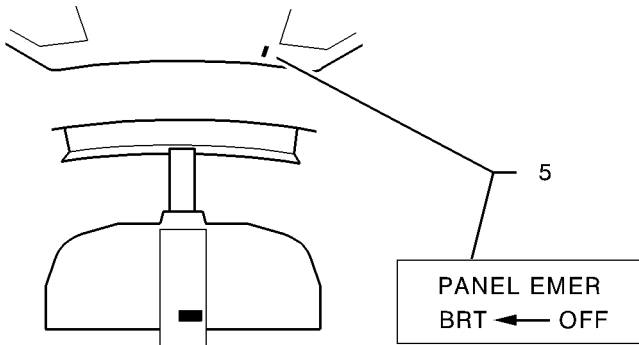

Figure 7.8.7 (2/2) - INTERNAL LIGHTING CONTROLS

INTENTIONALLY LEFT BLANK

7.9 - AIR CONDITIONING AND PRESSURIZATION

AIR CONDITIONING (Figure 7.9.1)

Air conditioning system includes the temperature and flow-pressure regulation system (ACS), the vapor cycle cooling system (VCCS), control and check systems and distribution.

Temperature and flow-pressure regulation system

Air necessary for conditioning is picked up from the engine. A valve regulates pressure and bleed hot air flow and is also used as shutoff valve. This valve is controlled by the "BLEED" switch. Hot air is cooled by going through a temperature exchanger and a cooling turbine, then it reduces the humidity through the water separator before entering the cabin through a check-valve.

Temperature exchanger is located in a duct which directs cooling air. This air is picked up outside by the NACA scoop located on R.H. FWD engine cowling. When the airplane is on ground, air flow is created by the cooling turbine driven by air picked up from the engine.

Temperature regulation is accomplished by adding hot air to the air coming from cooling turbine. An electronic control unit analyses the temperature of conditioned air, as it enters the cabin, as well as cabin ambient temperature and acts on the temperature regulation valve according to the requested temperature.

Vapor cycle cooling system

The vapor cycle cooling system improves the passengers and crew comfort in warm and / or humid atmospheric conditions. The refrigerant used is called R134A.

The installation comprises :

- A high pressure pack consisting of :
 - . a condenser heat exchanger,
 - . a condenser fan,
 - . a compressor,
 - . an electric motor,
 - . a receiver drier,
 - . two pressure switches,
 - . an overpressure relief valve.

The horseshoe condenser surrounds the electric motor, which directly drives the compressor.

The fan is driven by its own electric motor.

A low pressure switch (LP) rated at 0.725 psi (0.05 bars) and a high pressure switch (HP) rated at 406 psi (28 bars) ensure system safety by cutting out electrical power supply of the high pressure pack, when either pressure is reached. This pack is also equipped with an overpressure relief valve rated to open at 464 psi (32 bars).

The pack is installed in the FWD compartment between frames C1 and C2 inside a metallic housing. This housing is connected by means of a flexible duct with a screened air inlet located on the R.H. side in front of the windshield.

The high pressure pack is supplied by the "VENT" BUS bar.

- An evaporator heat exchanger,
- A fan,
- A solenoïd valve.

The evaporator heat exchanger is attached between frames C16 and C17 on L.H. side on baggage compartment floor. This exchanger has a thermal expansion valve controlled by a temperature control/sensor, which is installed on the hose at evaporator heat exchanger outlet.

The fan provides air circulation in the cabin through the evaporator. It is attached under the floor, on R.H. side, between frames C14 and C15. The fan is supplied by the "BUS 4" bar and protected by the CB 111 "FAN" circuit breaker.

The solenoid valve is installed on high pressure line and controlled by the high pressure pack. It is intended to avoid refrigerant migrations, when the system is off.

- Two service valves,

The low pressure (LP) service valve and the high pressure (HP) service valve are installed into supply hoses in the R.H. equipment compartment between frames C1 and C2.

Both valves fool-proofing is ensured by their different diameters ; LP service valve diameter is more important than HP one.

- A sight glass, used to check correct refrigerant filling without bubbles. It is located on the flexible hose at high pressure pack inlet.

- | | |
|--|---|
| 1) Heat exchanger/cooling turbine pack | 21) Cabin differential pressure switch |
| 2) Water separator | 22) Auxiliary volume tank |
| 3) Check valve | 23) Emergency air supply |
| 4) Duct overtemperature switch | 24) Controller |
| 5) Duct temperature sensor | 25) Compressor/condenser pack |
| 6) Demisting outlets | 26) Pressure regulator and shut-off valve |
| 7) Distribution box | 27) Overpressure switch |
| 8) Demisting microswitch | 28) Temperature control valve |
| 9) Air outlets and distribution orifices | 29) Water injector |
| 10) Outflow valve | 30) Overtemperature switch |
| 11) Safety valve | |
| 12) Cabin fan | |
| 13) Depressurization solenoïd valve | |
| 14) Evaporator | |
| 15) Refrigerant solenoïd valve | |
| 16) Cabin temperature sensor | |
| 17) Ground safety switch | |
| 18) Control panel | |
| 19) Cabin altitude switch | |
| 20) Advisory panel | |

Figure 7.9.1 (1/2) - AIR CONDITIONING

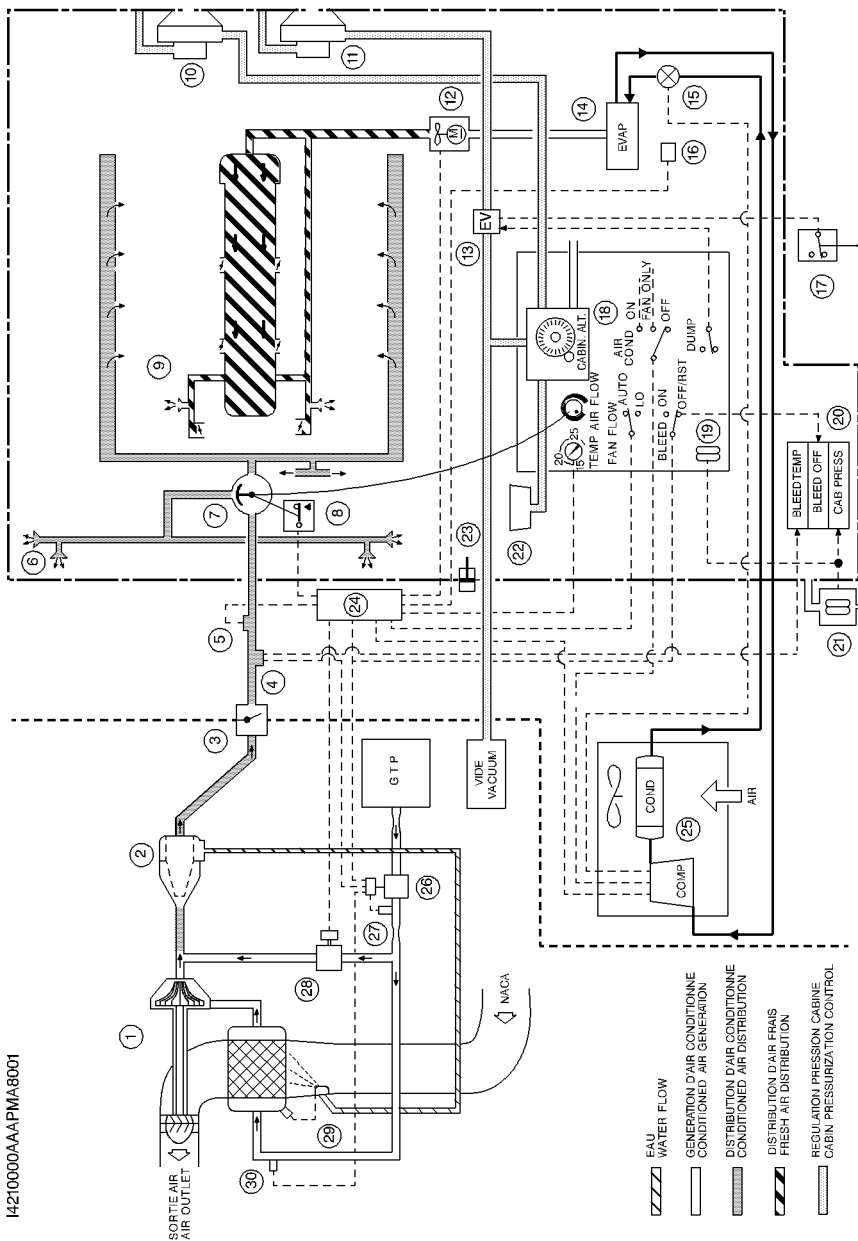

Figure 7.9.1 (2/2) - AIR CONDITIONING

When vapor cycle cooling system operation is requested by the controller, the compressor pressurizes the refrigerant and discharges it to the condenser heat exchanger through the HP pressure switch.

At the condenser heat exchanger outlet, refrigerant cooled by the condenser fan flows through the receiver drier to the thermal expansion valve located at the evaporator heat exchanger inlet.

The temperature control/sensor monitors the hose temperature at the evaporator heat exchanger outlet and pilots the thermal expansion valve opening or closing to control the refrigerant flow through the exchanger.

The expansion of the high pressure liquid refrigerant to a low pressure liquid extracts heat from the cabin air flowing through the evaporator and the low pressure refrigerant gas flows back to the compressor through the LP pressure switch.

The evaporator fan suctions hot and moistened cabin air through the evaporator heat exchanger and expels it cold and dry in a duct where it is blown into the cabin overhead duct equipped with air outlets and through air outlets located on arm rests of pilot and R.H. front passenger stations.

The system operates under two modes :

- engine running with "GENERATOR" selector on "MAIN",
- engine off with "SOURCE" selector on "GPU".

The system includes an automatic load shedding feature which operates when :

- "GENERATOR" selector is on "ST-BY",
- "AIRFRAME DE-ICE" switch is "ON",
- "PROP DE-ICE" switch is "ON",
- engine is started with system fed by a GPU.

Distribution

Conditioned air enters the distribution box from where it is dispatched either into the cabin through two outlets located at the level of rudder pedals, through a row of ports located on the lower section of the L.H. and R.H. side upholstery or through the demisting outlets. Each seat is also provided with a swivelling and adjustable air outlet, supplied with fresh air by the vapor cycle cooling system.

NOTE :

For a better efficiency of vapor cycle cooling system, do not obstruct air suction point at the level of baggage compartment.

Control and check (Figure 7.9.3)

AIR CONDITIONING SYSTEM

Air conditioning system controls are located on "ECS" panel and indicator lights are grouped on advisory panel.

Conditioning occurs when :

- "BLEED" switch is set to "ON", what leads to opening of pressure regulator and shut-off valve and switches off "BLEED OFF" warning light, and at the same time
- "AIR COND" switch is set to "ON", what ensures automatic regulation of cabin temperature.

Two overtemperature switches cause the illumination of "BLEED OFF" and "BLEED TEMP" warning lights located on advisory panel and simultaneously the closing of the pressure regulator and shut-off valve. These overtemperature switches are located at the temperature exchanger inlet and at the cabin inlet. System cannot be reactivated as long as "BLEED TEMP" warning light is illuminated. After "BLEED TEMP" warning light has gone out, set "BLEED" switch to "OFF/RST", then to "ON" to reactivate the system.

An air overpressure switch located after pressure regulator and shut-off valve causes the illumination of "BLEED OFF" warning light and simultaneously the closing of the pressure regulator and shut-off valve. To reactivate the system, set "BLEED" switch to "OFF/RST", then to "ON".

VAPOR CYCLE COOLING SYSTEM

The "AIR COND" switch has three positions :

- "OFF" : No automatic regulation of cabin temperature.
- "FAN ONLY" : Controls only cabin fan operation.
- "ON" : Controls operation of the cabin fan and automatic regulation of cabin temperature.

The "FAN FLOW" switch has two positions :

- "AUTO" : Selects full speed for the cabin fan, when "AIR COND" switch is set to "FAN ONLY" and lets controller manage speed, when "AIR COND" switch is set to "ON".
- "LO" : Selects low speed for the cabin fan.

"CABIN TEMP/°C" selector enables to select requested temperature in the cabin.

- An "ECS FAULT" amber light illuminates when the controller detects a faulty operation of ECS system.

NOTE :

- *If "ECS FAULT" light illuminates, inform maintenance service.*

"AIR FLOW" distributor directs air flow to demisting outlets ("DEFOG") or to the cabin ("CABIN").

Whatever the selected cabin temperature is, "HOT" position enables hot air to be directed only to demisting outlets and starts vapor cycle cooling system operation, when "AIR COND" switch is set to "ON".

Emergency air control ("RAM AIR" control knob), located under R.H. instrument panel facing control wheel, enables outside air to enter the cabin through a valve. In "NORMAL" position, the valve is closed and the control is locked. To open emergency ventilation valve, press on locking knob and move control rearwards.

PRESSURIZATION (Figures 7.9.2 and 7.9.3)

Pressurization system maintains the pressure corresponding to an altitude compatible with passengers' safety and comfort inside the cabin.

The system uses the air conditioning system to pressurize the cabin and the vacuum generation system for check and safety. Pressure controller, located on "ECS" panel allows pilot selecting :

- - a cabin altitude between sea level and 9350 ft,
- the cabin climb speed.

A three position indicator shows cabin altitude, cabin climb speed and cabin-atmosphere differential pressure. Cabin altitude is maintained by an outflow valve and a safety valve limits differential pressure between cabin and atmosphere at 6.2 psi (427 mb).

These valves are attached to rear pressure bulkhead and each one is connected to a static port located on rear cone for the outflow valve and under rear baggage compartment for safety valve.

Cabin is automatically depressurized as soon as the airplane is on ground through landing gear switch (airplane on ground) or, if necessary, by actuating "DUMP" switch located on "ECS" panel (in normal operation, this switch is protected and locked by a cover).

Indicating

In addition to the three purpose indicator, the system consists of the "CAB PRESS" warning light which illuminates when cabin altitude reaches 10000 ft or if cabin-atmosphere differential pressure exceeds 6.2 psi (427 mb).

NOTE :

*"CAB PRESS" warning light illumination has no effect on system functioning
- Refer to Section 3 "Emergency procedures".*

- 1) Check valve
- 2) Cabin differential pressure switch
- 3) Advisory panel
- 4) Outflow valve
- 5) Safety valve
- 6) Depressurization valve
- 7) Landing gear switch (airplane on ground)
- 8) Pressure controller
- 9) Cabin altitude switch
- 10) Auxiliary volume tank

Figure 7.9.2 (1/2) - PRESSURIZATION

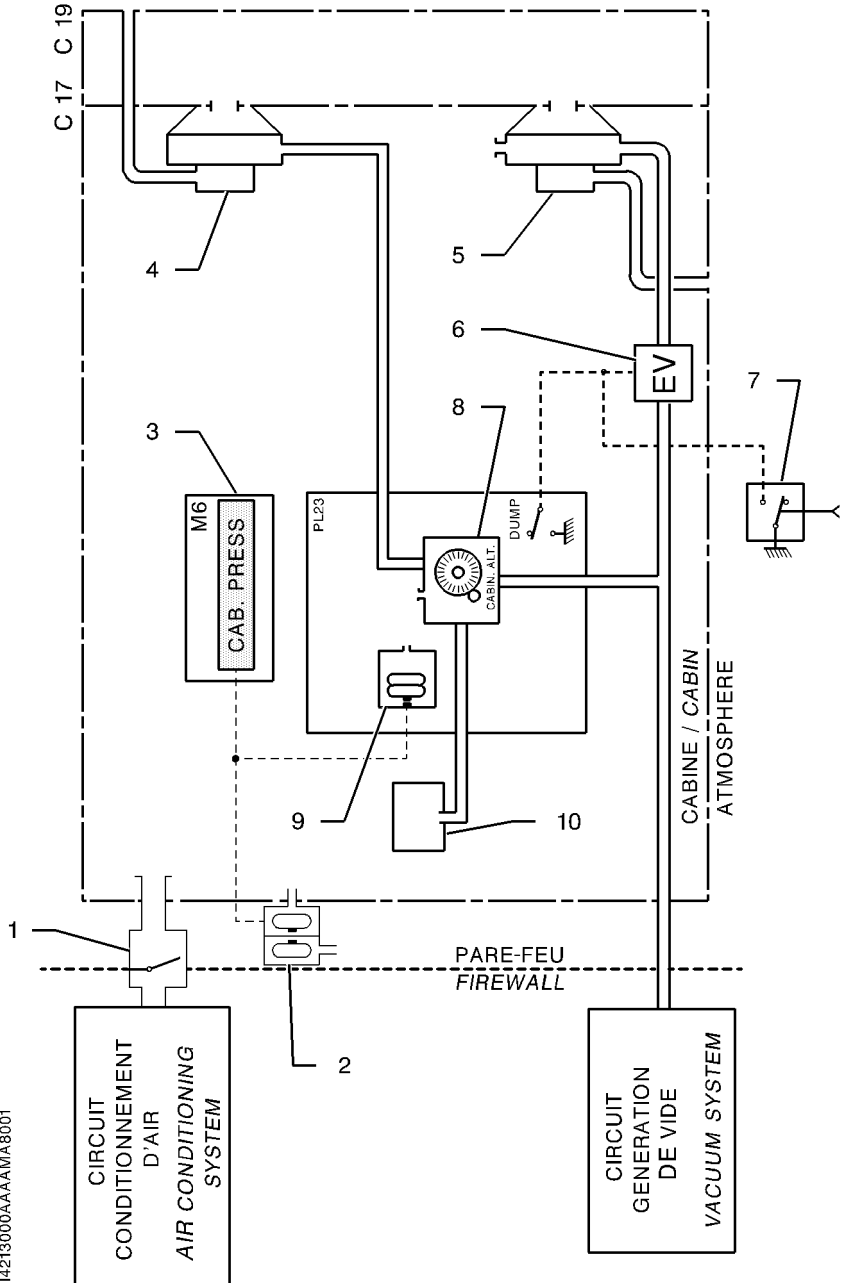

14215000AAAAA8001

Figure 7.9.2 (2/2) - PRESSURIZATION

- 1) Amber warning light
- 2) Warning light test push-button
- 3) "BLEED" switch - "ON/OFF/RST"
- 4) "AIR COND" switch - "ON/FAN ONLY/OFF"
- 5) "FAN FLOW" switch - "AUTO/LO"
- 6) "DUMP" switch
- 7) "AIR FLOW" distributor - "HOT/DEFOG/CABIN"
- 8) "CABIN TEMP/°C" selector
- 9) Cabin rate selector
- 10) Cabin altitude selector
- 11) Three-position indicator (cabin altitude, cabin climb speed and differential pressure)

Figure 7.9.3 (1/2) - "ECS" CONTROL AND CHECK PANEL

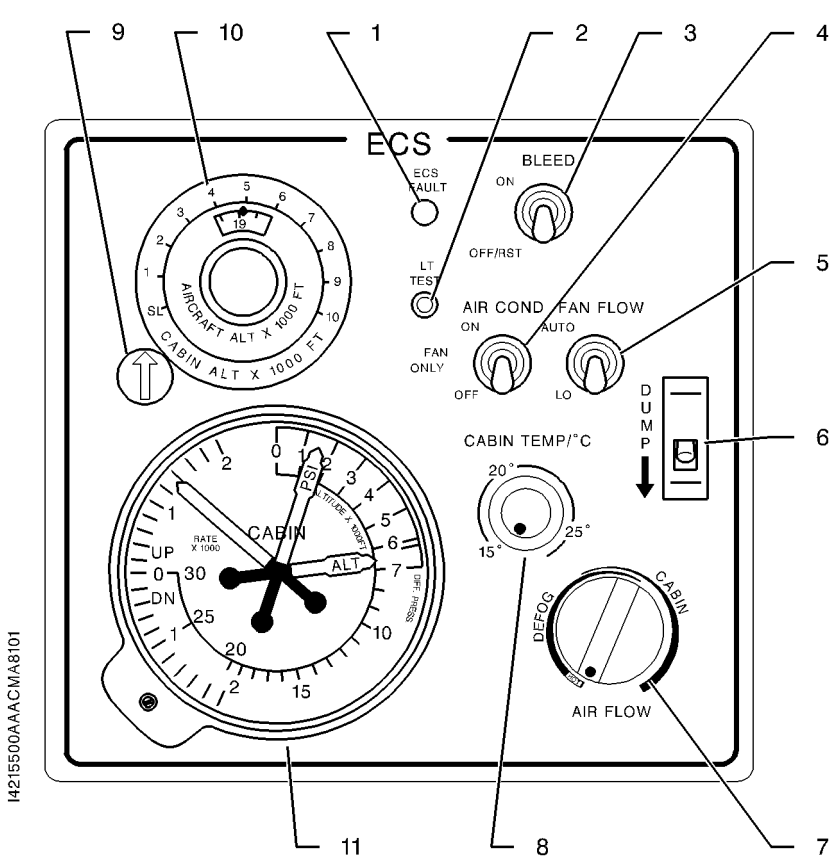
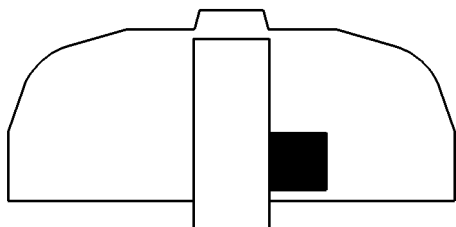

Figure 7.9.3 (2/2) - "ECS" CONTROL AND CHECK PANEL

INTENTIONALLY LEFT BLANK

7.10 - EMERGENCY OXYGEN SYSTEM (Figure 7.10.1)

The gaseous oxygen system will be used by the crew and the passengers, when the cabin altitude is greater than 10000 ft following a loss of pressurization or in case of cabin air contamination.

The oxygen reserve is contained in an oxygen cylinder made of composite material and located outside of the pressurized cabin into the R.H. karman. Its capacity is 50.3 cu.ft (1425 litres) "STPD" (Standard Temperature Pressure Dry) and use limit pressures are :

- maximum pressure 1850 PSIG (127 bars) at 70°F (21°C).
Evolution of this pressure according to the outside temperature is given in Section 8, Figure 8.7.4, as well as on a placard on the inside of the cylinder service door,
- minimum pressure 217 PSIG (15 bars).

The oxygen cylinder head is equipped with :

- a hand-controlled isolation valve to permit cylinder installation and removal,
- a microswitch supplying the "OXYGEN" warning light located on the advisory panel. This warning light illuminates, when the isolation valve is closed,
- a graduated pressure gage,
- a charging valve - refer to the replenishment procedure in Section 8,
- an overpressure system consisting of a safety disc. This disc is designed to rupture between 2500 and 2775 PSIG (172 and 191 bars) discharging the cylinder contents outboard,
- a pressure reducing valve adjusting utilization pressure to a value comprised between 64 and 85 PSIG (4.4 and 5.9 bars),
- a low pressure safety valve calibrated to 116 PSIG (8 bars).

1) Microphone switch

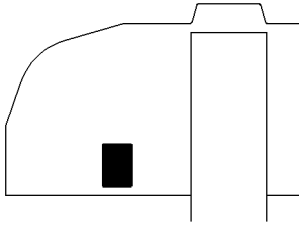

14351000AAAAMA18002

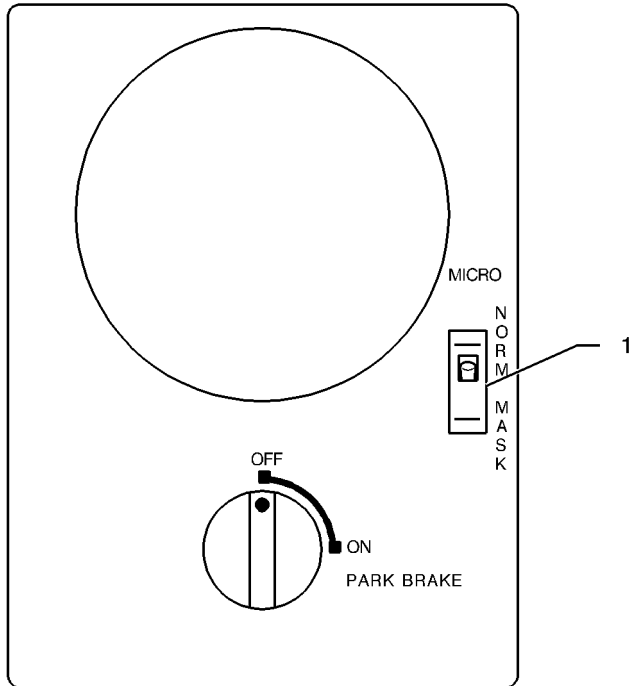

Figure 7.10.1 - EMERGENCY OXYGEN SYSTEM

An indicating and control panel located in the cockpit overhead panel at the disposal of the pilot includes :

- a graduated pressure gage to permit checking the cylinder charge,
- a two-position valve "ON/OFF" ("OXYGEN" switch) to permit the supply of the front seats occupiers masks,
- a two-position valve "ON/OFF" ("PASSENGERS OXYGEN" switch) with guard to permit the supply of the passengers four masks, when the first valve is open.

An altimetric valve provides an automatic passengers masks actuation function at a cabin altitude between 12500 and 14750 ft when "OXYGEN" switch is set to "ON".

Two pressure-demand type masks allowing quick donning with only one hand, covering the nose and the mouth, as well as two pairs of smoke goggles are at disposal of the pilot and of the R.H. front seat occupier. Masks are installed in cups on the cabin walls aft of the front seats. Permanently connected to the oxygen system, they are equipped with a micro controlled by the switch ("NORMAL/MASK" micro inverter) under cover located on the instrument panel near the pilot's control wheel, with a three-position selector "NORMAL", "100 %" and "EMERGENCY" and with a push-button "PRESS TO TEST". The proper flow is signaled by a flow indicator (blinker) into the oxygen tubing.

The smoke goggles are stowed in the drawer of the cabinet at the rear of the pilot.

Four passengers constant-flow type masks, covering the nose and the mouth and permanently connected, are installed in two containers on the cabin ceiling. The opening of these containers and the descent of the masks are controlled by the pilot, when both switches at its disposal are set to "ON", or automatically at a cabin altitude between 12500 and 14750 ft with the "OXYGEN" switch set to "ON". The oxygen flow is obtained by pulling on the mask bounded by a lanyard cord to a pin. A proper flow is signaled by the filling of the green bag located on each passenger mask.

WARNING

DO NOT SMOKE DURING OXYGEN SYSTEM USE.

**OIL, GREASE, SOAP, MAKE UP, LIPSTICK AND ANY OTHER GREASY
SUBSTANCES CONSTITUTE A SERIOUS FIRE OR BURNING
HAZARD, WHEN ON CONTACT WITH OXYGEN**

FLIGHT ABOVE 15000 FT WITH EMERGENCY DESCENT

Number of occupants		OUTSIDE TEMPERATURE						
Cockpit	Cabin	110°F/ 43°C	90°F/ 32°C	70°F/ 21°C	50°F/ 10°C	30°F/ -1°C	10°F/ -12°C	-10°F/ -23°C
1	0	631	614	597	580	563	546	529
1	1	759	736	713	691	668	646	623
1	2	885	856	828	799	771	743	715
1	3	1010	976	941	907	873	839	806
1	4	1137	1096	1056	1015	975	935	897
2	0	1037	1001	965	930	894	859	825
2	1	1164	1122	1080	1038	997	956	916
2	2	1289	1241	1192	1144	1097	1050	1004
2	3	1416	1361	1306	1252	1198	1145	1093
2	4	1541	1480	1418	1357	1297	1238	1180

(Values in PSIG)

Conditions :

1. 4 minutes from 31000 to 15000 ft. All equipment used from 31000 ft.
2. Plus 30 minutes usage by each pilot and passenger at 15000 ft.
3. Plus 86 minutes usage by each pilot at 10000 ft.

NOTE :

After a long parking time in the sunshine, increase pressures indicated in the table here above by 8 %.

WHEN REQUIRED TO REMAIN ABOVE 15000 FT DUE TO MINIMUM "EN ROUTE" ALTITUDE

Number of occupants		OUTSIDE TEMPERATURE						
Cockpit	Cabin	110°F/ 43°C	90°F/ 32°C	70°F/ 21°C	50°F/ 10°C	30°F/ -1°C	10°F/ -12°C	-10°F/ -23°C
1	0	618	602	585	569	552	536	520
1	1	842	816	789	763	736	710	685
1	2	1067	1029	992	955	918	882	846
1	3	1513	1240	1192	1144	1097	1050	1004
1	4	1513	1452	1392	1333	1275	1217	1161
2	0	992	958	925	891	858	825	793
2	1	1215	1170	1125	1081	1037	994	952
2	2	1439	1382	1326	1270	1215	1161	1108
2	3	1662	1593	1525	1457	1391	1326	1262
2	4	1888	1807	1725	1645	1567	1490	1415

(Values in PSIG)

Conditions :

1. Flight above 15000 ft. All equipment used.
2. 1 hour usage by each pilot and passenger.
3. Plus 1 hour usage by each pilot under 15000 ft.

NOTE :

After a long parking time in the sunshine, increase pressures indicated in the table here above by 8 %.

FLIGHT BETWEEN 15000 FT AND 10000 FT

Number of occupants		OUTSIDE TEMPERATURE						
Cockpit	Cabin	110°F/ 43°C	90°F/ 32°C	70°F/ 21°C	50°F/ 10°C	30°F/ -1°C	10°F/ -12°C	-10°F/ -23°C
1	0	618	602	585	569	552	536	520
1	1	961	929	896	864	833	801	770
1	2	961	929	896	864	833	801	770
1	3	961	929	896	864	833	801	770
1	4	961	929	896	864	833	801	770
2	0	992	958	925	891	858	825	793
2	1	1333	1282	1231	1181	1131	1083	1035
2	2	1333	1282	1231	1181	1131	1083	1035
2	3	1333	1282	1231	1181	1131	1083	1035
2	4	1333	1282	1231	1181	1131	1083	1035

(Values in PSIG)

Conditions :

1. Flight under 15000 ft.
2. 90 minutes usage by each pilot and one passenger.
3. Plus 30 minutes usage by each pilot at 10000 ft.

NOTE :

After a long parking time in the sunshine, increase pressures indicated in the table here above by 8 %.

7.11 - AIR DATA SYSTEM AND INSTRUMENTS (Figure 7.11.1)

Airplane air data system consists of :

- two separate static pressure systems supplying the altimeters, airspeed and vertical speed indicators. They also provide a static pressure reference to the ΔP cabin and to the Autopilot system Air Data Computer (ADC).

System 1 is backed up by an alternate system which operation is controlled by a switching valve (normal / alternate) attached to instrument panel under R.H. control wheel. In case of obstruction or icing of ports, this selector isolates airplane normal static system. When selector is on alternate position (pulled rearwards), static pressure is picked from a port located in airplane rear fuselage.

- two separate dynamic pressure systems supplying the airspeed indicators systems, V_{MO} audio warning detector and the Autopilot system Air Data Computer (ADC).

STATIC PRESSURE SYSTEMS

Primary systems

Two dual static ports (one on either side of the fuselage tail part) supply a dual system routed towards the cockpit.

System 1 is connected to the switching valve (normal / alternate) which supplies the encoding altimeter, the ΔP cabin, vertical speed 1 and airspeed 1 indicators and the Autopilot system Air Data Computer (ADC).

System 2 is directly connected to the second altimeter and optional equipment.

Both systems feature a drain valve located under the instrument panel on R.H. side. On static system 1, an additional drain is installed on ADC system. It is attached under floor and attainable through emergency landing gear door.

- 1) Pitot 1
- 2) Pitot 2
- 3) Pitot 2 dynamic drain
- 4) Pitot 1 dynamic drain
- 5) V_{MO} detector
- 6) Static drain
- 7) Emergency static drain
- 8) Static drain
- 9) FWD pressure bulkhead
- 10) Airspeed indicator 1
- 11) Encoding altimeter 1
- 12) Vertical speed indicator 1
- 13) ΔP cabin
- 14) Altimeter 2
- 15) Airspeed indicator 2
- 16) Vertical speed indicator 2
- 17) ADC dynamic drain
- 18) Autopilot system Air Data Computer (ADC)
- 19) Static source (Normal / Alternate)
- 20) Instrument panel
- 21) ADC static drain
- 22) Rear pressure bulkhead
- 23) R.H. static ports
- 24) Emergency bleed on frame C19
- 25) L.H. static ports

Figure 7.11.1 (1/2) - AIR DATA SYSTEM

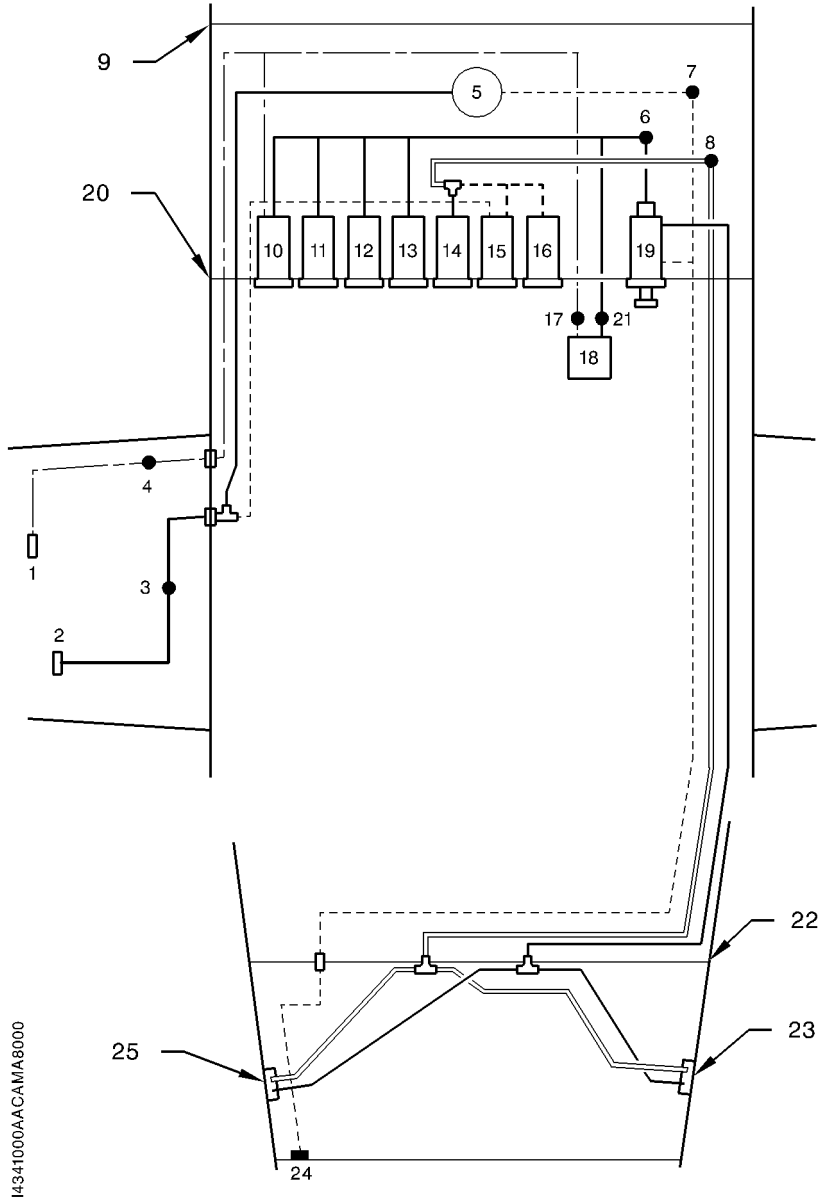

I4341000AACAMA8000

Figure 7.11.1 (2/2) - AIR DATA SYSTEM

Alternate static source

The alternate static port located in the rear fuselage supplies a system routed to the switching valve (normal / alternate) in order to replace static system 1 and also supplies the V_{MO} warning.

The alternate line incorporates a drain plug located under the instrument panel on R.H. side.

DYNAMIC PRESSURE SYSTEM

Two heated pitot probes are installed under the L.H. wing. The first one supplies the airspeed indicator 1 and the Autopilot system Air Data Computer (ADC).

The second one supplies the V_{MO} audio warning and optional equipment.

Both lines incorporate a drain plug located in the L.H. wing root. On dynamic system 1, an additional drain is installed on ADC system. It is located under the floor and is accessible from emergency landing gear door.

Pitot heating

Pitot heating is controlled by "PITOT 1 HTR" and "PITOT 2 & STALL HTR" switches, installed on "DE-ICE SYSTEM" panel.

"PITOT 1", "PITOT 2" and / or "STALL HTR" warning lights, located on the advisory panel are illuminated when corresponding switch is set to "OFF" or if heating system does not operate when the switch is set to "ON".

NOTE :

Do not use heating during prolonged periods on ground to avoid pitot overheat.

7.12 - VACUUM SYSTEM AND INSTRUMENTS (Figure 7.12.1)

The airplane is fitted with a vacuum system providing the suction necessary to operate the stand-by attitude indicator, the cabin pressurization and the leading edge deicing.

Vacuum system includes :

- A pressure regulator
- An ejector
- A regulating and relief valve
- A signalization microswitch
- A suction gage indicator

Compressed air necessary for the ejector to create decompressed air is taken from the power plant. The air flow is regulated before going into the ejector which creates necessary vacuum by venturi effect.

A relief valve fixed in cabin to frame C2, maintains the vacuum for pressurization and instrument systems. In case of pressure drop, a microswitch, installed in the system, indicates the failure by illuminating "VACUUM LO" warning light on the advisory panel.

ATTITUDE INDICATOR

The attitude indicator provides a visual reference of actual airplane flight attitude. An index at the top of the indicator shows bank attitude relative to the bank scale which has index marks at 10°, 20°, 30°, 60° and 90° either side of the center mark.

Pitch and roll attitudes are shown by a miniature airplane superimposed over a symbolic horizon area divided into two sections by a white horizon bar. The upper "sky blue" area and the lower "ground" area have arbitrary pitch reference lines useful for pitch attitude control.

- 1) Pressure regulator
- 2) Ejector
- 3) Valve
- 4) Regulating and relief valve
- 5) Pressure switch
- 6) Failure warning light (Figure 7.3.8)

Figure 7.12.1 (1/2) - VACUUM SYSTEM

14370000AAAPMA8000

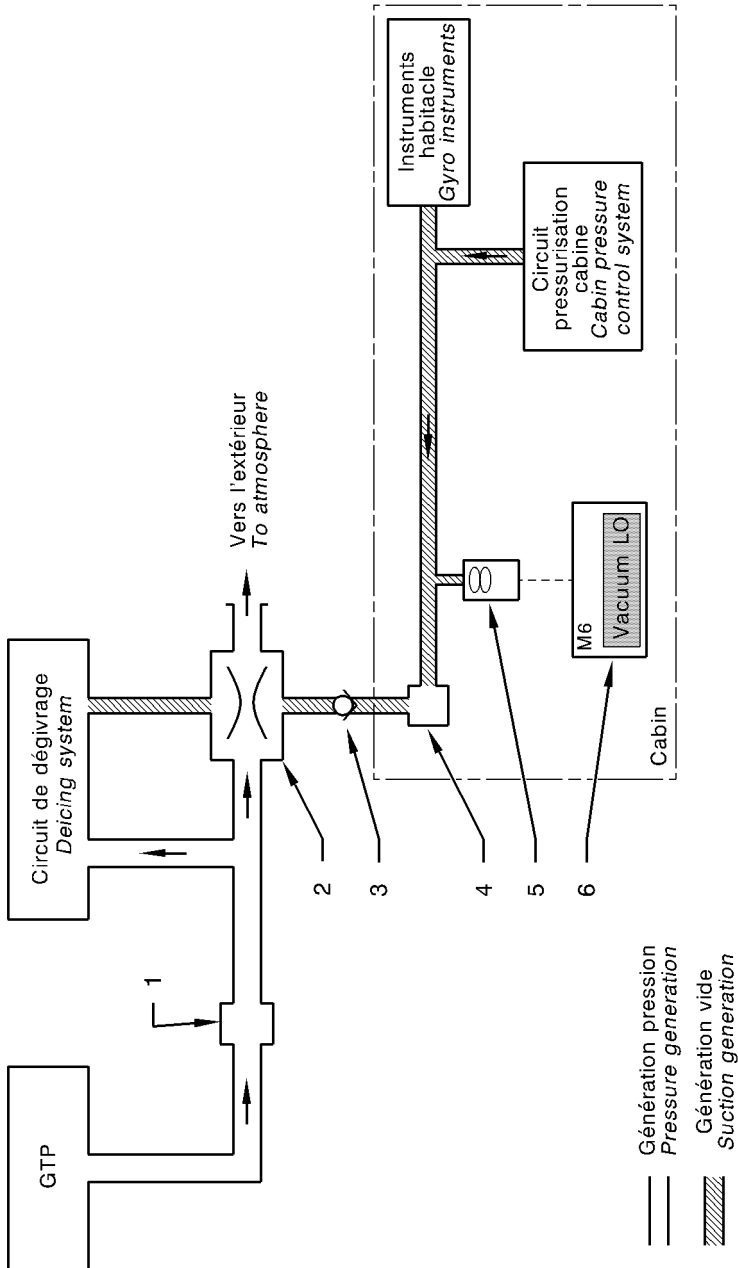
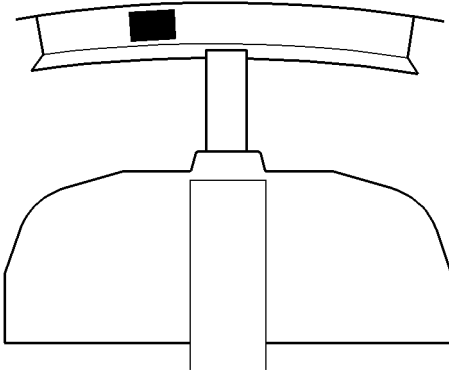

Figure 7.12.1 (2/2) - VACUUM SYSTEM



14342000AAADM/A8100

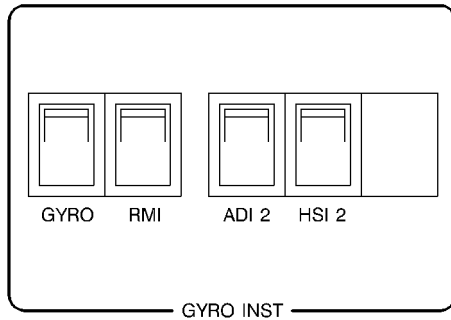

Figure 7.12.2 - GYROSCOPIC INSTRUMENTS CONTROL

GYROSCOPIC INSTRUMENTS CONTROL (Figure 7.12.2)

Gyroscopic instruments : electrical attitude gyros, HSI, RMI, ADI, etc... are controlled by switches located on instrument panel upper strip.

SUCTION GAGE

The suction gage is calibrated in inches of mercury and indicates the suction available for operation of the attitude indicator. The desired vacuum range is 4.4 to 5.2 in.Hg.

A vacuum reading out of this range may indicate a system malfunction or improper adjustment. In this case, all pneumatic instruments should be considered unreliable.

The suction gage is located on L.H. panel of pilot's instrument panel.

INTENTIONALLY LEFT BLANK

7.13 - ICE PROTECTION EQUIPMENT (Figure 7.13.1)

Ice protection equipment is as follows :

- Pneumatic deice system for inboard, central and outboard wing and for stabilizers : "AIRFRAME DE-ICE"
- Propeller electrical deice system : "PROP DE-ICE"
- Windshield electrical deice system : "L.WINDSHIELD" and "R.WINDSHIELD"
- Electrical heating system for both pitots and for the stall warning sensor : "PITOT 1 HTR" and "PITOT 2 & STALL HTR"
- Turbine air inlet deice systems : "INERT SEP"

Deicing check and control panel is located on the lower L.H. side of the instrument panel.

WING AND EMPENNAGE DEICING

A pneumatic deice system assures protection of wing leading edges, horizontal stabilizer, elevator horns and vertical stabilizer. The system automatically cycles when "AIRFRAME DE-ICE" switch is set to "ON". The 67-second cycle breaks down in two inflation cycles :

- a first cycle induces inflation of leading edges deicer boots in horizontal stabilizer, elevator horns, vertical stabilizer and wing inboard section,
- the second cycle induces inflation of leading edges deicer boots in wing central and outboard sections.

During each inflation cycle, one of the two corresponding warning lights located above "AIRFRAME DE-ICE" switch, remains illuminated.

Wing leading edge icing inspection light - see Chapter 7.8 Paragraph "EXTERIOR LIGHTING".

PROPELLER DEICING

Propeller deicing is accomplished through electrical heating of blade roots. This system operates cyclically and alternately on two opposite blades at the same time. Each cycle is 180 seconds long. The system operation is correct when green warning light located above "PROP DE ICE" switch illuminates. The cycles continue as long as the switch remains set to "ON".

WINDSHIELD DEICING

The windshields are deiced electrically by embedded heating resistors. The system includes a controller and two heat probes embedded in each windshield. They are operated by "L.WINDSHIELD" and "R.WINDSHIELD" switches.

When the switch is positioned to "ON", the controller supplies the heating resistors, the windshield temperature is monitored by probe # 1. When the temperature reaches 45°C (113°F), the controller cuts the electrical supply to the heating resistors and resumes supply when the temperature falls below 30°C (86°F). The cycle continues as long as the switch remains set to "ON".

In the event of failure by probe # 1, the controller receives the temperature data from probe # 2. The electrical supply to the heating resistors is cut when the windshield temperature reaches 56°C (133°F). In that case, the windshield is no longer heated, the pilot can reset the system by setting the switch to "OFF", then to "ON".

A green light located above "L.WINDSHIELD" and "R.WINDSHIELD" switches goes on when the heating resistors are being supplied.

**HEATING OF PITOTS AND STALL WARNING SENSOR ("PITOT 1 HTR"
AND "PITOT 2 & STALL HTR")**

The two pitots, which supply airspeed indicators and the stall warning sensor are electrically heated. This deice equipment must be used even during flight into non-icing conditions ; in that case ("PITOT 1 HTR", "PITOT 2 & STALL HTR" switches set to "ON") when "PITOT 1", "PITOT 2" or "STALL HTR" are lit, corresponding probe heating has failed.

NOTE :

Correct operation of the audible stall warning may be altered by severe or prolonged icing.

TURBINE AIR INLET PROTECTION

Operation and description are set forth in Chapter 7.6 Paragraph "ENGINE AIR INLET".

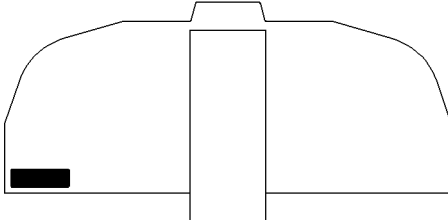

I4300001AAAAA8000

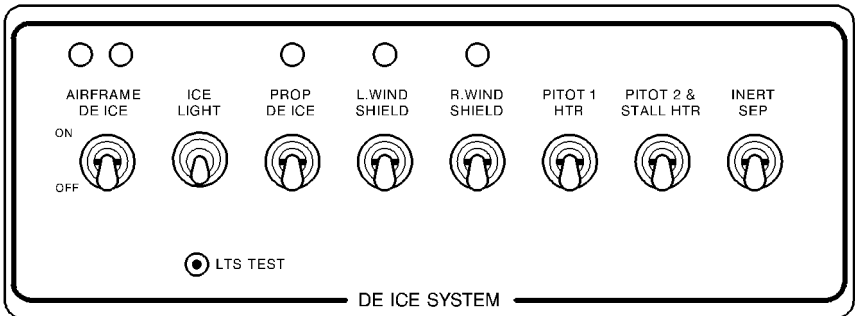

Figure 7.13.1 - DEICING CONTROL AND CHECK PANEL

7.14 - RADIO MASTER AND GROUND COMMUNICATION

(Figure 7.14.1)

The electrical supply of radio communication and radio navigation equipment assembly is controlled by the "RADIO MASTER" switch located on the "INT LIGHTS" panel.

Airplanes are equipped with the ground clearance function which enables to use the COM 1 installation from the BUS BAT when the "SOURCE" selector is "OFF". The ground clearance function is operating as soon as the "RADIO MASTER" switch is set to "ON" and the "SOURCE" selector is "OFF". The "GND CLR" green indicator light located near the "RADIO MASTER" switch is ON when the function is activated.

The "SOURCE" selector setting to the "BAT" or "GPU" positions de-activates the ground clearance function.

NOTE :

The electrical supply of radio communication and radio navigation equipment is automatically cut-off during the starting phase and is operating after the starter stop.

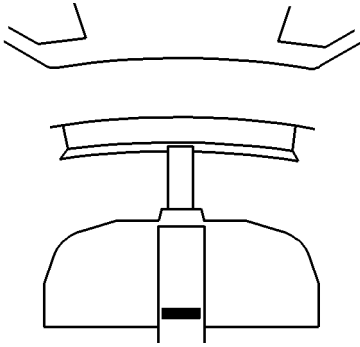

- 1) "RADIO MASTER" switch
- 2) "GND CLR" (ground clearance) ground communication indicator light

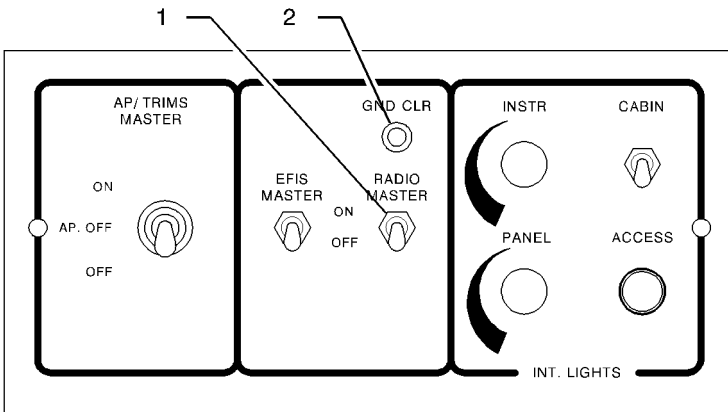
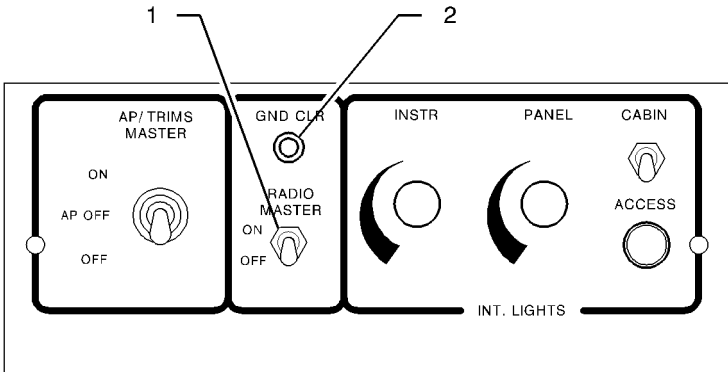

I423000AAA/EMA/8100

Figure 7.14.1 - RADIO MASTER AND GROUND COMMUNICATION

7.15 - MISCELLANEOUS EQUIPMENT

STALL WARNING SYSTEM

The airplane is equipped with an electrically deiced stall sensor in the leading edge of the right wing. This sensor fitted with a vane is electrically connected to an audible warning. The vane senses the change in airflow over the wing and operates the warning unit, which produces a tone over the alarm speaker. This warning tone begins between 5 and 10 knots above the stall in all configurations.

The stall warning system should be checked during the preflight inspection by momentarily turning on the "SOURCE" selector and by manipulating the vane in the wing. The system is operational if a continuous tone (low-pitched sound) is heard on the alarms speaker.

NOTE :

The audible stall warning may be altered by severe or prolonged icing.

STATIC DISCHARGERS

As an aid in flight, static dischargers are installed to improve radio communications during flight by reducing interference from dust or various forms of precipitations (rain, snow or ice crystals).

Under these conditions, the build-up and discharge of static electricity from the trailing edges of the wings (flaps and ailerons), rudder, stabilator, propeller tips and radio antennas can result in loss of usable radio signals on all communications and navigation radio equipment. Usually, the ADF is first and VHF communication equipment is the last to be affected.

Installation of static dischargers reduces interference from precipitation static, but it is possible to encounter severe precipitation static conditions which might cause the loss of radio signals, even with static dischargers installed. Whenever possible, avoid known severe precipitation areas to prevent loss of dependable radio signals. If avoidance is impractical, minimize airspeed and anticipate temporary loss of radio signals while in these areas.

CABIN FIRE EXTINGUISHER

The fire extinguisher is located behind FWD R.H. seat. It is attached on the floor by means of a quick-disconnect support. A pressure gage allows checking the fire extinguisher condition. Follow the recommendations indicated on the extinguisher.

Pre-MOD70-0391-26D

If there is a R.H. cabinet, the fire extinguisher is fixed on the cabinet or on the floor, between FWD R.H. seat and R.H. cabinet.

Post-MOD70-0391-26D

The fire extinguisher is located in the lower drawer of the R.H. cabinet, inserted in foam.

AUTOPILOT

Refer to Section 9 "Supplements".

EMERGENCY LOCATOR TRANSMITTER

The airplane is equipped with an emergency locator transmitter which enables to locate it in case of distress. It is located in fuselage rear section with a service door on fuselage R.H. side.

The emergency locator transmitter assembly is constituted of a transmitter supplied by a battery, of an antenna attached on upper fuselage and of a remote control located on R.H. instrument panel.

NOTE :

For test sequences, refer to manufacturer manual.

ELT ARTEX C406-1

Operation of the emergency locator transmitter is obtained as follows :

- from the instrument panel by setting "ON/ARM" remote control switch to "ON" (locator transmitter "ON/OFF" switch set to "OFF"),
- from the locator transmitter by setting its "ON/OFF" control switch to "ON",
- automatically in case of shock, when remote control switch is set to "ARM" and locator transmitter switch is set to "OFF".

A red indicator light located on "ELT" remote control switch in the cockpit indicates to the pilot the emergency locator transmitter is transmitting.

A red indicator light located above locator transmitter switch and a buzzer located in the fuselage rear section indicate the emergency locator transmitter is transmitting.

Reset after an inadvertent activation

- | | |
|---|--|
| 1) Set remote control switch or ELT switch to "ON". | a) The ELT keeps on transmitting emergency signal. |
| | b) On remote control box, red indicator light flashes. |
| | c) On ELT, red indicator light flashes. |
| | d) Near ELT, the buzzer sounds. |
| 2) Wait approximately for 1 second. | |
| 3) Set remote control switch to "ARM" or ELT switch to "OFF". | a) The ELT does not transmit emergency signal any longer. |
| | b) On remote control box, red indicator light illuminates for about 1 second, then goes off. |
| | or |
| | c) On ELT, red indicator light goes off. |
| | d) Near ELT, the buzzer does no more sound. |

CABIN FIRE EXTINGUISHER

The fire extinguisher is located behind FWD R.H. seat. It is attached on the floor by means of a quick-disconnect support. A pressure gage allows checking the fire extinguisher condition. Follow the recommendations indicated on the extinguisher.

AUTOPILOT

Refer to Section 9 "Supplements".

EMERGENCY LOCATOR TRANSMITTER

The airplane is equipped with an emergency locator transmitter which enables to locate it in case of distress. It is located in fuselage rear section with a service door on fuselage R.H. side.

The emergency locator transmitter assembly is constituted of a transmitter supplied by a battery, of an antenna attached on upper fuselage and of a remote control located on R.H. instrument panel.

NOTE :

For test sequences, refer to manufacturer manual.

ELT ARTEX C406-1

Operation of the emergency locator transmitter is obtained as follows :

- from the instrument panel by setting "ON/ARM" remote control switch to "ON" (locator transmitter "ON/OFF" switch set to "OFF"),
- from the locator transmitter by setting its "ON/OFF" control switch to "ON",
- automatically in case of shock, when remote control switch is set to "ARM" and locator transmitter switch is set to "OFF".

A red indicator light located on "ELT" remote control switch in the cockpit indicates to the pilot the emergency locator transmitter is transmitting.

A red indicator light located above locator transmitter switch and a buzzer located in the fuselage rear section indicate the emergency locator transmitter is transmitting.

Reset after an inadvertent activation

- | | |
|---|--|
| 1) Set remote control switch or ELT switch to "ON". | a) The ELT keeps on transmitting emergency signal.
b) On remote control box, red indicator light flashes.
c) On ELT, red indicator light flashes.
d) Near ELT, the buzzer sounds. |
| 2) Wait approximately for 1 second. | |
| 3) Set remote control switch to "ARM" or ELT switch to "OFF". | a) The ELT does not transmit emergency signal any longer.
b) On remote control box, red indicator light illuminates for about 1 second, then goes off.
or
c) On ELT, red indicator light goes off.
d) Near ELT, the buzzer does no more sound. |

ELT KANNAD 406 AF

Operation of the emergency locator transmitter is obtained as follows :

- from the instrument panel by setting "ON/ARMED/RESET-TEST" remote control switch to "ON" (locator transmitter "ARM/ON/OFF" switch set to "ARM"),
- from the locator transmitter by setting its "ARM/ON/OFF" control switch to "ON",
- automatically in case of shock, when remote control switch is set to "ARMED" and locator transmitter switch is set to "ARM".

A red indicator light located on "ELT" remote control switch in the cockpit indicates to the pilot the emergency locator transmitter is transmitting.

A red indicator light located above locator transmitter switch and a buzzer located in the fuselage rear section indicate the emergency locator transmitter is transmitting.

Reset after an inadvertent activation

On "ON/ARMED/RESET-TEST" remote control switch, press on "RESET-TEST" or set locator transmitter switch to "OFF", then to "ARM".

SECTION 8

HANDLING, SERVICING AND MAINTENANCE

TABLE OF CONTENTS

	Page
8.1 GENERAL	8.1.1
8.2 IDENTIFICATION PLATE	8.2.1
8.3 PUBLICATIONS	8.3.1
8.4 INSPECTION PERIODS	8.4.1
8.5 ALTERATIONS OR REPAIRS	8.5.1
8.6 GROUND HANDLING	8.6.1
TOWING	8.6.1
PARKING	8.6.1
TIE-DOWN	8.6.3
JACKING	8.6.3
LEVELING	8.6.3
FLYABLE STORAGE	8.6.5
LONG TERM STORAGE WITHOUT FLYING	8.6.5
8.7 SERVICING	8.7.1
MAINTENANCE	8.7.1
ENGINE OIL	8.7.1
FUEL	8.7.2
LANDING GEAR	8.7.7
OXYGEN	8.7.8
ETM DATAKEY OPERATION	8.7.14

TABLE OF CONTENTS

(Continued)

	Page
8.8 AIRPLANE CLEANING AND CARE	8.8.1
WINDSHIELD AND WINDOWS	8.8.1
PAINTED SURFACES	8.8.2
PROPELLER CARE	8.8.2
ENGINE CARE	8.8.2
INTERIOR CARE	8.8.2
8.9 UTILIZATION BY COLD WEATHER (- 0°C to - 25°C) OR VERY COLD WEATHER (- 25°C to - 40°C)	8.9.1

8.1 - GENERAL

This section contains the procedures recommended by the manufacturer for the proper ground handling and routine care and servicing of TBM 700 airplane. Also included in this section are the inspection and maintenance requirements which must be followed if your airplane is to retain its performance and dependability.

It is recommended that a planned schedule of lubrication and preventive maintenance be followed, and that this schedule be tailored to the climatic or flying conditions to which the airplane is subjected.

For this, see Manufacturer's Maintenance Manual.

INTENTIONALLY LEFT BLANK

8.2 - IDENTIFICATION PLATE

Any correspondence regarding your airplane should include its serial number. This number together with the model number, type certificate number and production certificate number are stamped on the identification plate attached to the left side of the fuselage beneath the horizontal stabilizer.

INTENTIONALLY LEFT BLANK

8.3 - PUBLICATIONS

When the airplane is delivered from the factory, it is supplied with a Pilot's Operating Handbook and supplemental data covering optional equipment installed in the airplane (refer to Section 9 "Supplements" and pilot's guides).

In addition, the owner may purchase the following :

- Maintenance Manual
- Wiring Manual
- Illustrated Parts Catalog (Bilingual)
- Illustrated Tool and Equipment Manual
- Catalog of Service Bulletins, Service Letters and Service Information Letters

CAUTION

**PILOT'S OPERATING HANDBOOK MUST ALWAYS
BE IN THE AIRPLANE**

INTENTIONALLY LEFT BLANK

8.4 - INSPECTION PERIODS

Refer to regulations in force in the certification country for information concerning preventive maintenance to be carried out.

A maintenance Manual must be obtained prior to performing any preventive maintenance to make sure that proper procedures are followed. Maintenance must be accomplished by licensed personnel.

INTENTIONALLY LEFT BLANK

8.5 - ALTERATIONS OR REPAIRS

It is essential that the Airworthiness authorities be contacted prior to any alterations or repairs on the airplane to make sure that airworthiness of the airplane is not violated. Alterations or repairs must be accomplished by licensed personnel.

INTENTIONALLY LEFT BLANK

8.6 - GROUND HANDLING

CAUTION

ONLY MOVE OR TOW THE AIRPLANE WITH SOMEONE IN THE COCKPIT

TOWING

CAUTION

USING THE PROPELLER FOR GROUND HANDLING COULD RESULT IN SERIOUS DAMAGE, ESPECIALLY IF PRESSURE OR PULL IS EXERTED ON BLADE TIPS

The airplane should be moved on the ground with a towing bar and a suitable vehicle in order not to damage the nose gear steering mechanism. Nose gear fork is equipped with an integrated towing fitting.

CAUTION

DO NOT TOW THE AIRPLANE WHEN CONTROLS ARE SECURED

WHEN TOWING WITH A VEHICLE, DO NOT EXCEED THE NOSE GEAR TURNING ANGLE, AS THIS MAY RESULT IN DAMAGE TO THE GEAR AND STEERING MECHANISM

(see Figure 8.6.1)

PARKING

When parking the airplane, head it into the wind. Do not set the parking brake when brakes are overheated or during cold weather when accumulated moisture may freeze the brakes. Care should be taken when using the parking brake for an extended period of time during which an air temperature rise or drop could cause difficulty in releasing the parking brake or damage the brake system.

Make sure that the fuel selector is set to "OFF".

14091000AAAABMA8000

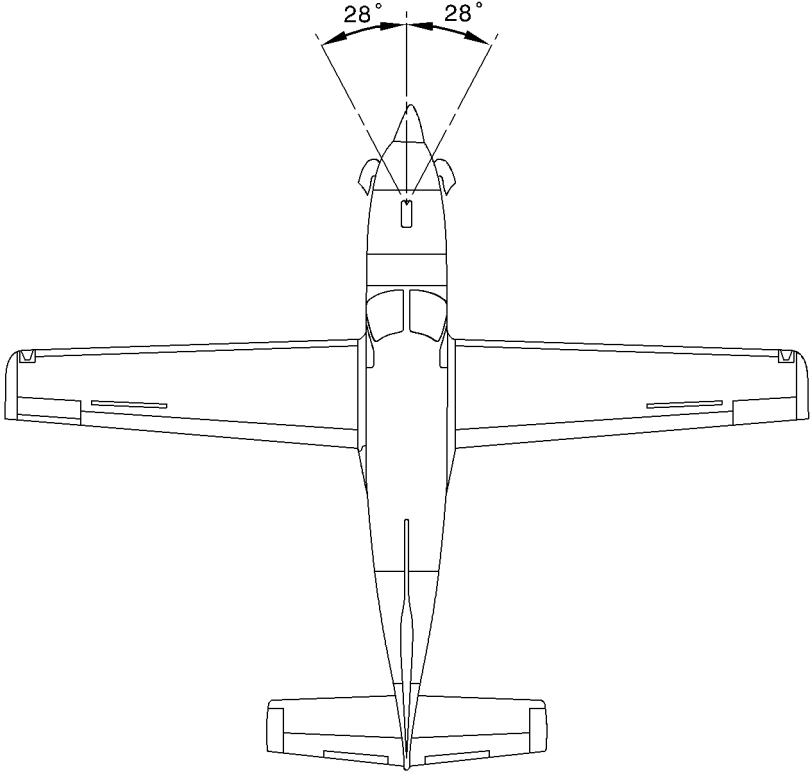

Figure 8.6.1 - TURNING ANGLE LIMITS

NOTE :

Do not use solar screens or shields installed on the airplane inside, or leave sun visors down against windshield when airplane on ground. The reflected heat from these items causes a temperature increase which accelerates the crack growth or crazing and may cause the formation of bubbles in the inner layer of multilayer windshields.

Beyond 24 hours parking, use windshield protection screen provided with lateral and underside straps.

For long term parking, blanking covers (static ports, pitot, engine air inlet), cockpit cover, tie-downs, wheel chocks and control lock are recommended.

In severe weather and high wind conditions, tie the airplane down as outlined in the following paragraph.

TIE-DOWN

Proper tie-down procedure is the best protection against damage to the airplane by gusty or strong winds. To tiedown the airplane securely, proceed as follows :

- Install control lock (see Figure 8.6.2).
- Chock all wheels.
- Tie sufficiently strong ropes or chains to hold airplane down ; insert a rope in each tie-down hole located on flap hinge arm ; secure each rope to a ramp tie-down or to mooring rod.
- Check that doors are closed and locked.

JACKING

When it is necessary to jack the airplane off the ground, refer to Maintenance Manual for specific procedures and equipment required.

LEVELING

Level the airplane as described in Maintenance Manual.

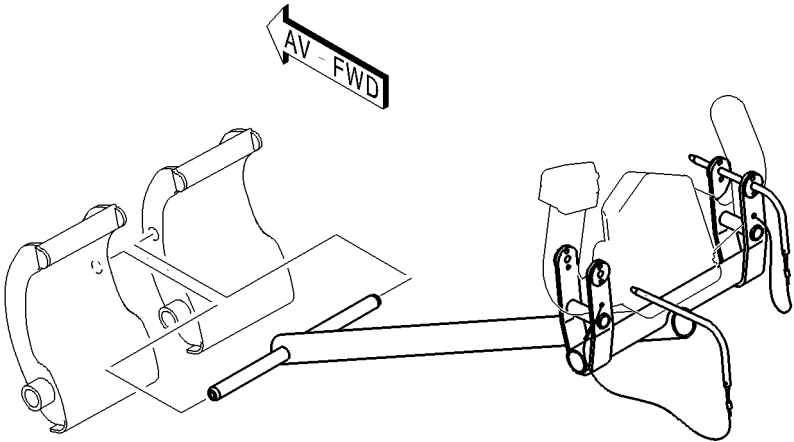
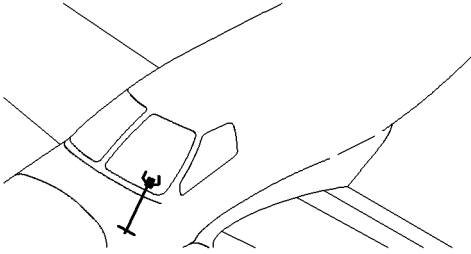

14101000AAADMA8002

Figure 8.6.2 - CONTROL LOCK DEVICE

FLYABLE STORAGE

Airplanes placed in storage for a maximum of 28 days are considered in flyable storage.

Storage from 0 to 7 days :

- Engine : according to Maintenance Manual P & W C.

Airplane fueling :

- Keep fuel tanks full to minimize condensation in the tanks. Keep the battery fully charged to prevent the electrolyte from freezing in cold weather.

Close oxygen cylinder isolation valve.

Storage from 8 to 28 days :

- Engine : according to Maintenance Manual P & W C.

Airplane fueling :

- Keep fuel tanks full to minimize condensation in the tanks. Keep the battery fully charged to prevent the electrolyte from freezing in cold weather.

Close oxygen cylinder isolation valve.

Battery (remaining in the airplane or removed) :

- Disconnect battery and check its charge level at regular intervals.

LONG TERM STORAGE WITHOUT FLYING

Refer to Maintenance Manual for the procedures to follow.

INTENTIONALLY LEFT BLANK

8.7 - SERVICING

MAINTENANCE

In addition to the preflight inspection (refer to Section 4, "Normal Procedures"), servicing, inspection and test requirements for the airplane are detailed in the Maintenance Manual.

Maintenance Manual outlines all items which require servicing, inspection, testing or overhaul.

ENGINE OIL

Type of oil :

CAUTION

DO NOT MIX DIFFERENT BRANDS OR TYPES

Nominal viscosity	US specification (US)	French specification (FR)	English specification (UK)	NATO code
Type 5cSt	MIL-L-23699C Amdt 1	MIL-L-23699C Amdt 1	DERD 2499 Issue 1	O.156

Figure 8.7.1 - RECOMMENDED ENGINE OIL TYPES
(Reference : Service Bulletin P & W C. No. 14001)

Oil capacity :

System total capacity :

12.7 Quarts (12 Litres) (oil cooler included)

Usable capacity :

6 Quarts (5.7 Litres)

The engine oil should be changed and the oil filter cleaned at intervals recommended in Pratt & Whitney Canada Service Bulletin No. 14001 which has been updated with revisions and / or Supplements.

Refill through the system filling inlet which is located on the engine upper rear part. A gage located on the filling cap indicates oil level and is calibrated in quarts to maximum level under cold conditions "MAX COLD" and to maximum level under hot conditions "MAX HOT". Normal oil level is approximately one quart below maximum level.

To avoid over servicing of oil tank and high oil consumption, check oil level within 10 minutes after engine shutdown.

If more than 10 minutes but less than 30 minutes have passed and the dipstick indicates that oil is needed, carry out a normal dry motoring cycle and reverify level before adding oil.

If more than 30 minutes have passed and the dipstick indicates that oil is needed, start the engine and run at ground idle (low idle) for 5 minutes. Reverify oil level before adding oil.

FUEL

Total capacity each tank : 145.3 us gal (550 l).

NOTE :

To minimize condensation, it is recommended that airplane be refueled after each flight, respecting weight and balance limits.

CAUTION

NEVER FLY THE AIRPLANE WITH CONTAMINATED (WATER, SAND, RUST, DUST...) OR UNAPPROVED FUEL

■ Before each flight and after each fueling, use a sampler to bleed off some fuel through each tank and fuel filter drain to detect possible contamination and be sure that fuel used is the proper quality. If there is contamination present, continue draining through all draining points until fuel is free of contamination. If quality of fuel used is not correct, defuel airplane completely and refuel with proper quality fuel.

CAUTION

DURING FUELING OPERATIONS, TAKE CARE NOT TO DAMAGE PNEUMATIC DEICER BOOTS LOCATED ON WING LEADING EDGE.

THE USE OF AVIATION GASOLINE (AVGAS) MUST BE RESTRICTED TO EMERGENCIES ONLY. AVGAS WILL NOT BE USED FOR MORE THAN 150 CUMULATIVE HOURS DURING ANY PERIOD BETWEEN ENGINE OVERHAUL

WARNING

DURING ALL FUELING OPERATIONS, FIRE FIGHTING EQUIPMENT MUST BE AVAILABLE ; ATTACH GROUNDING WIRE TO AN UNPAINTED METALLIC PART OF THE AIRPLANE.

DO NOT OPERATE ANY AVIONICS OR ELECTRICAL EQUIPMENT ON THE AIRPLANE DURING FUELING. DO NOT ALLOW OPEN FLAME OR SMOKING IN THE VICINITY OF THE AIRPLANE WHILE FUELING

NOTE :

Use of AVGAS must be recorded in engine module logbook

US Specification (US)	French Specification (FR)	English Specification (UK)	NATO Code
ASTM-D1655 JET A ASTM-D1655 JET A1 ASTM-D1655 JET B	AIR 3405C Grade F35	DERD 2494 Issue 9	F35 without additive
MIL-DTL-5624 Grade JP-4	AIR 3407B	DERD 2454 Issue 4 Amdt 1	F40 with additive
MIL-DTL-5624 Grade JP-5	AIR 3404C Grade F44	DERD 2452 Issue 2 Amdt 1	F44 with additive when utilization
MIL-DTL-83133 Grade JP-8	AIR 3405C Grade F34	DERD 2453 Issue 4 Amdt 1	F34 with additive S748
	AIR 3404C Grade F43	DERD 2498 Issue 7	F43 without additive

Figure 8.7.2 - RECOMMENDED FUEL TYPES
(Reference : Service Bulletin P & W C. No. 14004)

Fuel additives

Fuel used must contain an anti-ice additive conforming to MIL-I-27686 or MIL-I-85470 specification.

Strict adherence to recommended preflight draining instructions as called for in Section 4 will eliminate any free water accumulations from the tank sumps. While small amounts of water may still remain emulsified in the gasoline, it will normally be consumed and go unnoticed in the operation of the engine.

One exception to this can be encountered when operating under the combined effect of use of certain fuels, with high humidity conditions on the ground followed by flight at high altitude and low temperature. Under these unusual conditions, small amounts of water emulsified can precipitate from the fuel stream and freeze in sufficient quantities to induce partial icing of the engine fuel system.

While these conditions are quite rare and will not normally be a problem to owners and operators, they do exist in certain areas of the world and consequently must be dealt with, when encountered.

Therefore, to alleviate the possibility of fuel icing occurring under these unusual conditions, it is required to add an ethylene glycol monomethyl ether (EGME or DIEGME) compound to the fuel supply.

The introduction of an EGME or DIEGME compound into the fuel provides two distinct effects :

- it absorbs the dissolved water from the fuel
- alcohol has a freezing temperature depressant effect.

EGME or DIEGME must be carefully mixed with the fuel in concentration, it must be between a minimum of 0.06 % and a maximum of 0.15 % by volume. Figure 8.7.3 provides EGME or DIEGME / fuel mixing ratio information.

CAUTION

DO NOT PERMIT THE CONCENTRATE OF EGME OR DIEGME TO COME IN CONTACT WITH THE AIRPLANE FINISH OR FUEL TANK

MIXING OF THE EGME OR DIEGME WITH THE FUEL IS EXTREMELY IMPORTANT. AN EXCESSIVE CONCENTRATION (GREATER THAN 0.15 % BY VOLUME MAXIMUM) WILL RESULT IN DETRIMENTAL EFFECTS TO THE FUEL TANKS BY DETERIORATION OF PROTECTIVE PRIMER, SEALANTS AND SEALS OF SYSTEM AND ENGINE COMPONENTS. USE ONLY BLENDING EQUIPMENT RECOMMENDED BY THE MANUFACTURER TO OBTAIN PROPER PROPORTIONING.

Prolonged storage of the airplane will result in a water buildup in the fuel which "leeches out" the additive. An indication of this is when an excessive amount of water accumulates in the fuel tank sumps. The concentration can be checked using a differential refractometer. It is imperative that the technical manual for the differential refractometer be followed explicitly when checking the additive concentration.

Fuel and fuel additives in Ukraine and CIS countries

It is possible to use kerosene GOST 10227 RT with addition of anti-icing liquid :

- "ДНК" - GOST 13302-77 or
- liquid "И" - GOST 8313-88 or
- "ТГФ" М – TU-6-10-1457

with antistatic additives "СИГБ 01" – TU 38.101741-78.

Above-mentioned liquids are added in the quantity equal to 0.1 percent (up to 0.3 percent with regard to anti-icing liquid used) per volume.

CAUTION

REFER TO SERVICE BULLETIN P & WC No. 14004 AT ITS LATEST REVISION FOR APPROPRIATE QUANTITIES

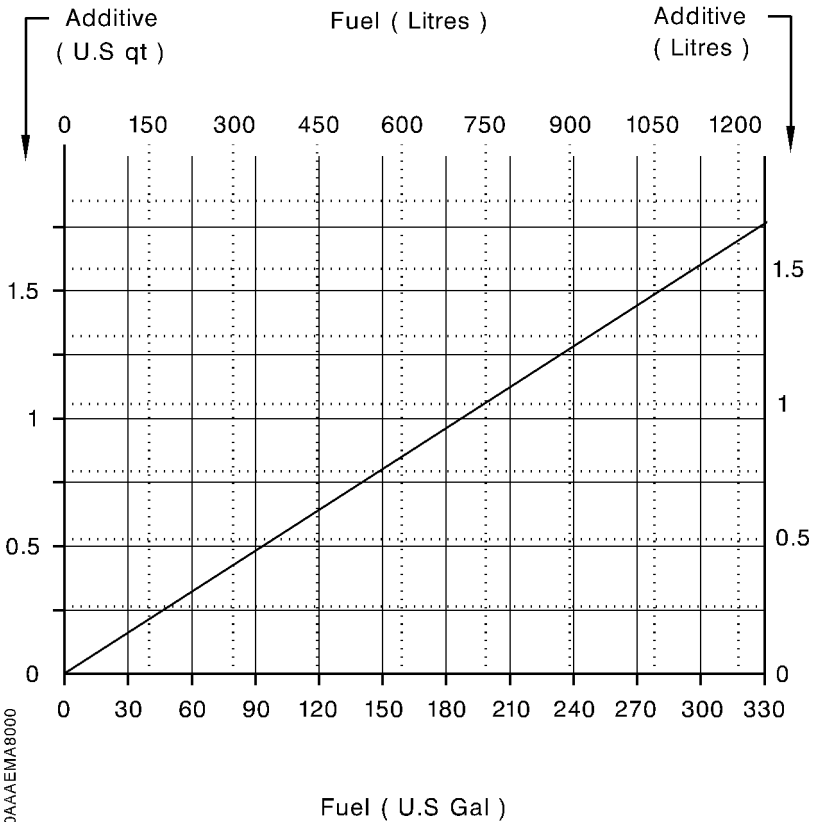

14284000AAAEIMA8000

Figure 8.7.3 - ADDITIVE MIXING RATIO (EGME or DIEGME)

LANDING GEAR

■ (Refer to Supplement 41 for TBM 700C2 airplane)

Nose gear tire :

5.00-5 10 PR – Inflation pressure : 98 psi (6.7 bars) *

Main gear tires :

18 5.5 8 PR – Inflation pressure : 125 psi (8.6 bars) *

Nose gear shock absorber :

Fill with hydraulic fluid AIR 3520 B (MIL.H5606E) ; inflate with nitrogen to 87 psi (6 bars).

Main gear shock absorbers :

Fill with hydraulic fluid AIR 3520 B (MIL.H5606E) ; inflate with nitrogen to 160 psi (11 bars).

Hydraulic system :

Check every 100 hours and service with AIR 3520 B (MIL.H5606E) hydraulic fluid.

Brakes :

Service as required with AIR 3520 B (MIL.H5606E) hydraulic fluid.

NOTE :

A higher inflation pressure has to be applied to tires and shock absorbers when in very cold conditions (refer to Chapter 8.9).

(*) Tire inflation pressures are given for an airplane on ground at 21 °C.
An ambient temperature change of 3 °C produces approximately 1 % pressure change.

OXYGEN

The replenishment device of the oxygen cylinder is installed directly on the cylinder head. It consists of a charging valve and of a pressure gage graduated from 0 to 2000 PSIG. A chart – see Figure 8.7.4, located on the inside of the cylinder service door, gives the cylinder charge maximum pressure according to the environment temperature.

I4112400AAAAA8000

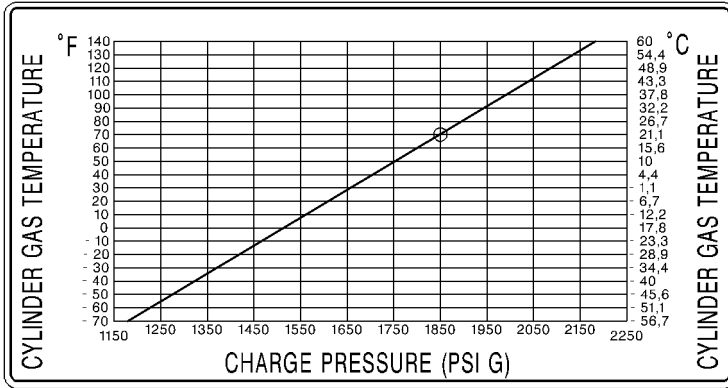

Figure 8.7.4 - Charge pressure chart

Replenishment procedure**WARNING**

MAKE SURE THAT THE AIRPLANE IS FITTED WITH A GROUING CABLE AND IS PROPERLY GROUNDED. THE OXYGEN CART MUST BE ELECTRICALLY BONDED TO THE AIRPLANE.

DO NOT OPERATE THE AIRPLANE ELECTRICAL SWITCHES OR CONNECT/DISCONNECT GROUND POWER DURING OXYGEN SYSTEM REPLENISHMENT.

DO NOT OPERATE THE OXYGEN SYSTEM DURING REFUELING/DEFUELING OR PERFORM ANY OTHER SERVICING PROCEDURE THAT COULD CAUSE IGNITION.

INTRODUCTION OF PETROLEUM BASED SUBSTANCES SUCH AS GREASE OR OIL TO OXYGEN CREATES A SERIOUS FIRE HAZARD. USE NO OIL OR GREASE WITH THE OXYGEN REPLENISHMENT EQUIPMENT.

ALWAYS OPEN SHUT-OFF VALVE SLOWLY TO AVOID GENERATING HEAT AND REPLENISH THE SYSTEM SLOWLY AT A RATE NOT EXCEEDING 200 PSIG (13.7 BARS) PER MINUTE

CAUTION

REPLENISHMENT OF THE OXYGEN SYSTEM SHOULD ONLY BE CARRIED OUT BY QUALIFIED PERSONNEL

NOTE :

The cylinder full charge is assured for a pressure of 1850 PSIG (127 bars) at a temperature of 70°F (21°C). If the cylinder temperature differs from 70°F (21°C), refer to Figure 8.7.4 which lists the required pressures according to the cylinder temperature.

Open the oxygen service door on the R.H. rear karman.

Measure the oxygen cylinder temperature.

Make sure the thermometer indication is constant. Note the indication.

Refer to the temperature/pressure chart for the correct oxygen cylinder pressure.

If the pressure on the oxygen cylinder gage is lower, fill the oxygen cylinder.

Make sure the area around the oxygen cylinder charging valve is clean. Remove the cap from the charging valve.

Make sure the oxygen supply hose is clean and connect it to the charging valve.

Slowly pressurize the oxygen cylinder to the correct pressure.

Close the oxygen supply and let the cylinder temperature become stable.

Monitor the oxygen pressure on the gage and fill to the correct pressure if necessary.

Release the pressure in the oxygen supply hose and disconnect from the charging valve.

Install the cap on the charging valve.

Make sure all the tools and materials are removed and the work area is clean and free from debris.

Close the oxygen service door.

Passengers' masks repacking instructions

WARNING

DO NOT USE OIL OR OTHER PETROLEUM BASED LUBRICANTS ON PASSENGER OXYGEN MASK OR DEPLOYMENT CONTAINER. OIL BASED LUBRICANTS ARE A FIRE HAZARD IN OXYGEN-RICH ENVIRONMENTS

WARNING

REPACKING PROCEDURES SHALL BE PERFORMED BY PERSONNEL FAMILIAR WITH THE INSTRUCTIONS AND WARNINGS IN THIS DOCUMENT. IMPROPERLY PACKED MASKS CAN DAMAGE THE MASKS OR RESULT IN FAILURE OF THE MASKS TO DEPLOY

WARNING**MASKS SHALL BE REPACKED IN AN AREA FREE OF OIL, GREASE,
FLAMMABLE SOLVENTS OR OTHER CONTAMINANTS**

Inspect and disinfect mask and deployment container with an aqueous solution of Zephiran Chloride ("Scott Aviation" P/N 00-2572) or with disinfection cleaners ("EROS" P/N SAN50). After disinfecting and thoroughly drying the mask, lightly dust the outside of the facepiece with Neo-Novacite powder ("Scott Aviation" P/N 00-736). Contamination can be removed with mild soap and water solution.

Fold headstrap into facepiece. Pull lanyard cord out to side of facepiece so that it does not interfere with repacking.

Lay reservoir bag on flat surface and smooth out wrinkles.

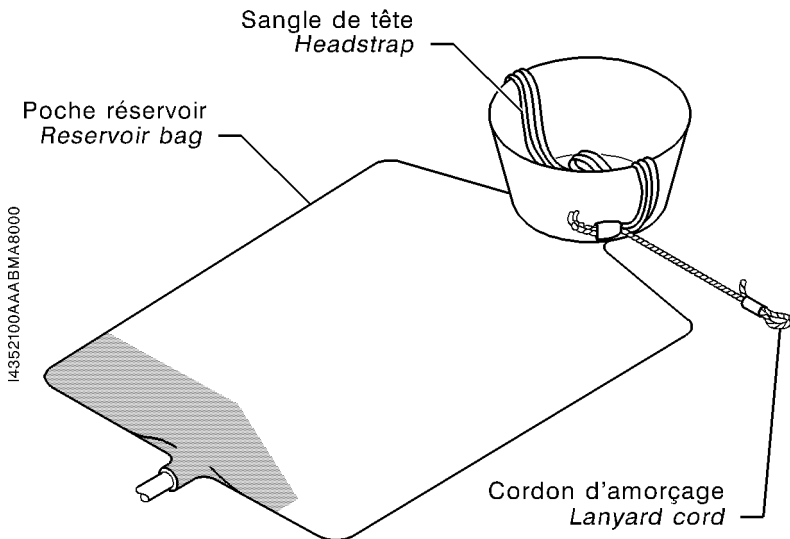

Gently fold reservoir bag lengthwise into thirds (outside edges folded inward over center of bag). Do not crease bag.

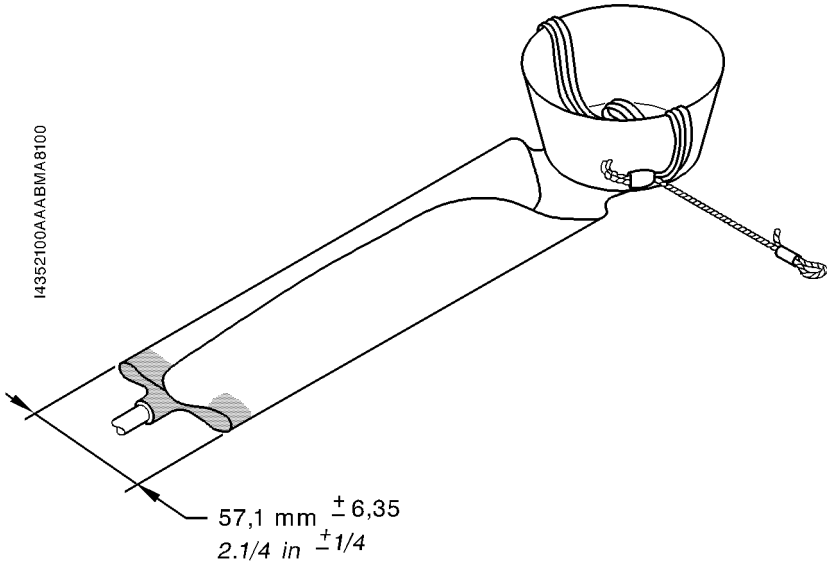

Fold reservoir bag away from breathing valves and into facepiece. Make sure bag does not cover breathing valves.

Vue de dessus
Top view

Vue de dessous
Bottom view

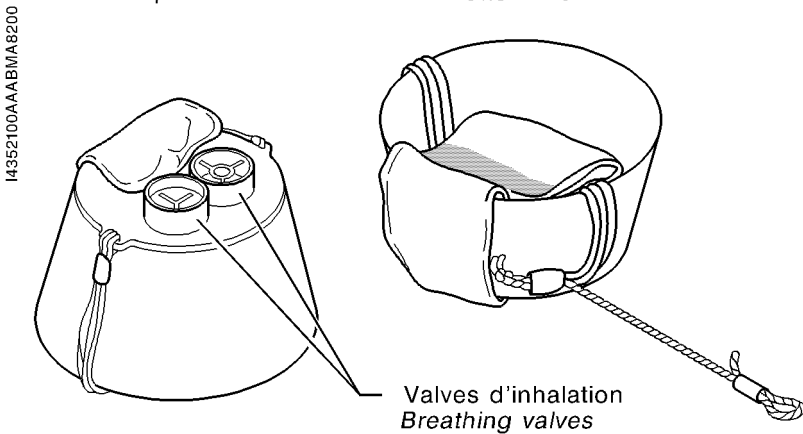

Coil oxygen tubing inside facepiece over reservoir bag.

14352100AAA BMA 18000

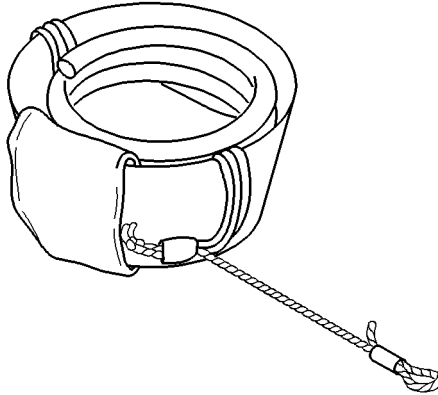

Connect oxygen tubing to manifold oxygen fitting.

WARNING

MAKE SURE LANYARD PIN IS INSERTED INTO CORRECT CHECK VALVE FOR MASK BEING INSTALLED. CROSS CONNECTED PINS WILL RESULT IN PASSENGERS PULLING LANYARD CORDS ONLY TO INITIATE OXYGEN FLOW TO ANOTHER MASK

Insert lanyard pin into corresponding check valve.

Place mask facepiece - first in deployment container. Make sure that oxygen tubing and lanyard cord are free to deploy and are not caught between the container and lid.

Close and latch deployment container lid.

ETM DATAKEY OPERATION

The key is inserted into its receptacle in the airplane prior to turning power on and removed after power is turned off. While inserted the reports which are recorded during the flight are electronically written to a memory chip in the key. When the key is removed from the airplane, it can then be carried to a personal computer with a receptacle attached for the key and downloaded.

Operating using the Datakey

- a) Insert initialized key into airplane receptacle prior to power up (turn 90°).
- b) Conduct flight.
- c) Remove key after power down.

NOTE :

The key will hold several flights of data depending of the number of events per flight. The key should be downloaded as soon as practical after removal. Exposure to electrostatic charges may cause permanent damage.

8.8 - AIRPLANE CLEANING AND CARE

WINDSHIELD AND WINDOWS

The windshield and windows should be cleaned with an airplane windshield cleaner.

NOTE :

Refer to the Maintenance Manual for products and procedures to apply.

Apply the cleaner sparingly with soft cloths and rub with moderate pressure until all dirt, oil scum and bug stains are removed. Allow the cleaner to dry, then wipe it off with soft flannel cloth.

CAUTION

DO NOT USE ANY OF THE FOLLOWING PRODUCTS ON, OR FOR CLEANING WINDOWS : METHANOL, METHYLATED ALCOHOL, GASOLINE, BENZENE, XYLENE, METHYL-ETHYL-KETONE, ACETONE, CARBON TETRACHLORIDE, LACQUER PAINT THINNERS, COMMERCIAL OR HOUSEHOLD WINDOW CLEANING SPRAYS. IN CASE OF DOUBT CONCERNING A PRODUCT, DO NOT USE IT.

DURING CLEANING OPERATION, AVOID WEARING OBJECTS SUCH AS RING, WATCH, BRACELET AND EXERCISE CARE TO PREVENT BUTTONS, BUCKLES AND ANY HARD OBJECTS FROM TOUCHING THE WINDSHIELD AND THE WINDOWS.

ADHESIVE TAPES OTHER THAN MINNESOTA 3M TYPE 670 SHALL NOT BE USED ON ACRYLIC SURFACES.

NEVER USE BUFFING MACHINES AS EXCESSIVE FORCES OR SPEEDS MIGHT PRODUCE REDHIBITORY DEFECTS

Follow by carefully washing with a mild detergent and plenty of water. Rinse thoroughly, then dry with a clean moist chamois. Do not rub the plastic with a dry cloth since this builds up an electrostatic charge which attracts dust. Waxing will finish the cleaning operation. A thin, even coat of wax polished out by hand with clean soft flannel cloth will fill in minor scratches and help prevent further scratching.

Do not use a canvas cover on the windshield unless freezing rain or sleet is anticipated since the cover may scratch the plastic surface.

PAINTED SURFACES

Refer to Maintenance Manual for the products and procedures to apply.

PROPELLER CARE

Preflight inspection of propeller blades for nicks and cleaning them occasionally with a cloth soaked with soapy water to clean off grass and bug stains will assure long blade life. Small nicks on the propeller, particularly near the tips and on the leading edges, should be dressed out as soon as possible since these nicks produce stress concentrations, and if not removed, may result in cracks. Never use an alkaline cleaner on the blades ; remove grease and dirt.

ENGINE CARE

Refer to Maintenance Manual for the procedures to follow.

INTERIOR CARE

To remove dust and loose dirt from the upholstery and carpet, clean the interior regularly with a vacuum cleaner.

For additional information, refer to Maintenance Manual.

8.9 - UTILIZATION BY COLD WEATHER (- 0°C TO - 25°C) OR VERY COLD WEATHER (- 25°C TO - 40°C)

■ (Refer to Supplement 41 for TBM 700C2 airplane)

If a landing is foreseen by cold or very cold weather or in case of airplane prolonged operation in such conditions, it is recommended to prepare the airplane as follows :

- 1 - Smear with silicone grease the door and engine cowlings seals, as well as the leading edge deicers.
- 2 - Apply engine oil on the engine cowling latches.
- 3 - Inflate main landing gear shock absorbers to 247 psi (17 bars) at a room temperature of 15°C.
- 4 - Position a 0.59 in (15 mm) shim at the bottom of the piston tube and against forward landing gear half-fork to reduce shock absorber travel. Refill with hydraulic liquid. Remove the shim and inflate shock absorber to 138 psi (9.5 bars) at a room temperature of 15°C.
- 5 - Inflate main landing gear tires to 131 psi (9 bars) and nose tire to 102 psi (7 bars) at a room temperature of 15°C.

Check pressure values and inflate, if necessary, according to following table 1 during operation in cold weather only :

		OAT (°C)	- 40°	- 30°	- 20°	- 10°	+ 15°
P R E S S U R E S psi (bars)	Main landing gear shock absorber		189 (13)	196 (13.5)	203 (14)	218 (15)	247 (17)
	Nose gear shock absorber		102 (7)	109 (7.5)	116 (8)	123 (8.5)	138 (9.5)
	Main landing gear tire		120 (8.25)	120 (8.25)	131 (9)	131 (9)	131 (9)
	Nose gear tire		94 (6.5)	94 (6.5)	102 (7)	102 (7)	102 (7)

Table 1

INTENTIONALLY LEFT BLANK

LIST OF SUPPLEMENTS AND VALIDITIES

Supp. No.		Edition Date
A -	General <u>All</u> From S/N 1 to S/N 433, except S/N 269	31.01.90
1 -	"BENDIX / KING" autopilot type KFC 275 <u>TBM 700A and TBM 700B</u> From S/N 1	31.03.90
2 -	"BENDIX / KING" vertical speed and altitude selector type KAS 297C <u>All</u> From S/N 1 to S/N 433, except S/N 269	31.03.90
3 -	"BENDIX / KING" RDS 81 weather radar <u>TBM 700A and TBM 700B</u> From S/N 1	30.11.90
4 -	"BENDIX / KING" RDS 82 weather radar <u>TBM 700A and TBM 700B</u> From S/N 1	30.11.90
5 -	"BENDIX / KING" RDS 82 VP vertical profile weather radar <u>TBM 700A and TBM 700B</u> From S/N 1	30.11.90
6 -	"BFG" WX-500 or WX-950 or WX-1000 or 1000+ or 1000E stormscope <u>All</u> From S/N 1	30.11.90
7 -	7-place accomodation <u>TBM 700A and TBM 700B</u> From S/N 1	28.02.91

LIST OF SUPPLEMENTS AND VALIDITIES (cont'd)

Supp. No.	Edition Date
8 - "BENDIX / KING" GC 381A radar graphics interface <u>TBM 700A and TBM 700B</u> From S/N 1	28.02.91
9 - "BENDIX / KING" EFS 40 <u>All</u> From S/N 1 to S/N 433, except S/N 269	31.05.91
10 - "BENDIX / KING" autopilot type KFC 325 <u>All</u> From S/N 1 to S/N 433, except S/N 269	31.05.91
11 - "CASEY COPTER" freon air conditioning <u>TBM 700A</u> From S/N 24	31.05.92
12 - Window and capability of Camera / Observation <u>TBM 700A</u> From S/N 1	31.01.94
13 - "BENDIX / KING" KLN90A GPS navigation system interfaced with HSI KI 525A <u>TBM 700A and TBM 700B</u> From S/N 1	30.04.94
14 - "BENDIX / KING" KLN90A GPS navigation system interfaced with EHSI OF EFS 40 <u>TBM 700A and TBM 700B</u> From S/N 1	30.06.94
15 - "KEITH" vapor cycle cooling system <u>TBM 700A and TBM 700B</u> From S/N 96	30.06.94

LIST OF SUPPLEMENTS AND VALIDITIES (cont'd)

Supp. No.		Edition Date
16	"BENDIX / KING" KRA 405 radar altimeter <u>All</u> From S/N 1 to S/N 433, except S/N 269	30.09.95
17	"BENDIX / KING" KLN90B GPS navigation system interfaced with EHSI OF EFS 40 <u>TBM 700A and TBM 700B</u> From S/N 1	30.04.96
18	"L'HOTELLIER" Engine fire detection system <u>All</u> From S/N 1	31.01.96
19	"SHADIN" ETM (Engine Trend Monitor) <u>TBM 700A, TBM 700B and TBM 850</u> From S/N 1	31.01.96
20	"BENDIX / KING" GC 360A radar graphics interface <u>TBM 700A and TBM 700B</u> From S/N 1	29.02.96
21	"BENDIX / KING" KLN90B GPS navigation system interfaced with the HSI KI525A <u>TBM 700A and TBM 700B</u> From S/N 1	30.04.96
22	"BENDIX / KING" RDR 2000 vertical profile weather radar <u>All</u> From S/N 1 to S/N 433, except S/N 269	30.06.96
23	AMS 44 dual channel audio control box <u>TBM 700A</u> From S/N 1	31.07.96

LIST OF SUPPLEMENTS AND VALIDITIES (cont'd)

Supp. No.		Edition Date
24 -	"NAVCAL" flight inspection system capability <u>TBM 700A</u> From S/N 1	31.07.96
25 -	"EVENTIDE" ARGUS 7000 CE moving map display <u>TBM 700A and TBM 700B</u> From S/N 1	10.06.98
26 -	"BENDIX / KING" KLN90B GPS (B-RNAV) navigation system interfaced with EFS 40 EHSI <u>TBM 700A, TBM 700B and TBM 700C</u> From S/N 1	30.11.98
27 -	"BENDIX / KING" KLN90B GPS (B-RNAV) navigation system interfaced with electromechanical HSI <u>TBM 700A and TBM 700B</u> From S/N 1	15.06.99
28 -	"BFG" SKYWATCH SKY 497 or SKY 899 traffic advisory system <u>All</u> From S/N 1 to S/N 433, except S/N 269	31.08.99
29 -	"EROS/INTERTECHNIQUE" gaseous oxygen system (30000 ft) <u>TBM 700A and TBM 700B</u> From S/N 40, plus S/N 24 and 36	30.09.99
30 -	Cargo transportation capability TBM 700B and TBM 700C1 airplanes equipped with option OPT70 52002A "Pilot door"	15.06.01
31 -	Intentionally left free	

LIST OF SUPPLEMENTS AND VALIDITIES (cont'd)

Supp. No.		Edition Date
32	- "GARMIN GNS 430" GPS navigation system interfaced with electromechanical instruments <u>TBM 700A and TBM 700B</u> From S/N 1	30.04.00
33	- Intentionally left free	
34	- "GARMIN GNS 430" GPS (B-RNAV) navigation system interfaced with EHSI OF EFS 40 <u>TBM 700A and TBM 700B</u> From S/N 1	31.08.00
35	- "HONEYWELL" KMD 850 Multi-function display <u>TBM 700B, TBM 700C and TBM 850</u> From S/N 192 to S/N 433, except S/N 269	31.01.01
36	- "GARMIN GNS 530" GPS (B-RNAV) navigation system interfaced with EHSI OF EFS 40 <u>All</u> From S/N 1 to S/N 433, except S/N 269	31.10.01
37	- "EROS/INTERTECHNIQUE" gaseous oxygen system (31000 ft) <u>TBM 700A and TBM 700B</u> From S/N 40, plus S/N 24 and 36	30.08.01
38	- Operation at 31000 ft <u>TBM 700A and TBM 700B</u> From S/N 40, plus S/N 24 and 36	30.08.01
39	- KGP 560 "HONEYWELL" EGPWS system <u>All</u> From S/N 1 to S/N 433, except S/N 269	31.10.01
40	- Cargo transportation capability without pilot door TBM 700 airplanes equipped with the large door	15.11.01

LIST OF SUPPLEMENTS AND VALIDITIES (cont'd)

Supp. No.	Edition Date
41 - TBM 700C2 <u>TBM 700C2</u> From S/N 244, plus S/N 205 and S/N 240	15.02.03
42 - "HONEYWELL" KMH 880 EGPWS/TAS system <u>All</u> From S/N 1 to S/N 433, except S/N 269	30.09.02
43 - Provision for TBM 700C2 <u>TBM 700C1</u> From S/N 244, plus S/N 205 and S/N 240	10.12.02
44 - Chip detection system <u>All</u> From S/N 1	10.02.05
45 - Intentionally left free	
46 - "GARMIN" GMX 200 Multi-function display <u>All</u> TBM airplanes equipped with option OPT70 34040F From S/N 1 to S/N 433, except S/N 269	31.10.06

***The Supplement Revision 24 is approved under authority of DOA
EASA.21J.013.***

Approval Number : EASA.21J.013 09013 DAG/N DOA

Date : May 20, 2009

SUPPLEMENT

**"BENDIX / KING" VERTICAL SPEED AND
ALTITUDE SELECTOR
TYPE KAS 297C**

TABLE OF CONTENTS

	Page
1 - GENERAL	9.2.2
2 - LIMITATIONS	9.2.2
3 - EMERGENCY PROCEDURES	9.2.2
4 - NORMAL PROCEDURES	9.2.3
5 - PERFORMANCE	9.2.6
6 - WEIGHT AND BALANCE	9.2.6
7 - DESCRIPTION	9.2.7

SECTION 1

GENERAL

This supplement is provided to acquaint the pilot with the limitations as well as the normal and emergency operating procedures of the BENDIX / KING KAS 297C Vertical Speed and Altitude Selector when added to a KFC 275 or KFC 325 Flight Control System.

The KAS 297C provides the pilot with the following features : ability to select vertical speed hold ; ability to select, arm and, upon approaching the selected altitude, automatically transfer into Altitude Hold ; altitude alerting as specified by the regulation.

SECTION 2

LIMITATIONS

When the airplane is equipped with the KAS 297C, in addition to the autopilot, limitations are identical to those of the standard airplane plus those of the autopilot.

Refer to Section 2 "Limitations" of the basic Pilot's Operating Handbook and of the Autopilot Supplement.

SECTION 3

EMERGENCY PROCEDURES

No change in the basic emergency procedures of the airplane described in Section 3 "Emergency Procedures" of the basic Pilot's Operating Handbook and of the Autopilot Supplement.

SECTION 4
NORMAL PROCEDURES

These procedures supplement those of standard airplane described in Section 4 "Normal procedures" of the basic Pilot's Operating Handbook and of the Autopilot Supplement.

BEFORE TAXIING

KAS 297C TEST

- 1 - "TEST" knob of KMC 321 **PRESS**
- 2 - Check :
 - All legends and digits are displayed on the KAS 297C.

VERTICAL SPEED MODES

MODE ENGAGEMENT

- 1 - Select knob **PULL, then ROTATE**
to display the desired vertical speed
- 2 - "ENG" push-button **PRESS**

VERTICAL SPEED CHANGE

- 1 - Using "CWS"
 - "CWS" push-button **PRESS**
until the desired vertical speed is displayed
 - "CWS" push-button **RELEASE**
when the desired vertical speed is reached

The autopilot will maintain the desired vertical speed.



ALTITUDE PRESELECT MODES

MODE ENGAGEMENT

- 1 - Select knob **PRESS, then ROTATE to display the desired altitude**
- 2 - "ARM" push-button **PRESS**
- 3 - Display an airplane attitude or a longitudinal mode ("IAS" or "VS") necessary to intercept the selected altitude.

SECTION 5

PERFORMANCE

No change in the basic performance of the airplane described in Section 5 "Performance" of the basic Pilot's Operating Handbook.

SECTION 6

WEIGHT AND BALANCE

Weight and balance corresponding to the KAS 297C "BENDIX KING" autopilot are given in the optional equipment list attached to Section 6 "Weight and balance" of the basic Pilot's Operating Handbook.

SECTION 7
DESCRIPTION

7.1 - KAS 297C CONTROLS AND DISPLAYS

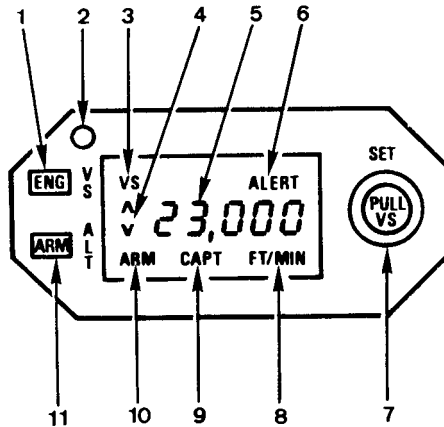

5-4-700-22-0003

Figure 9.2.1 - KAS 297C CONTROLS AND DISPLAYS

- Item 1 - **VERTICAL SPEED MODE (ENG) BUTTON**
When pressed will engage the Vertical Speed Hold mode. When pressed a second time will disengage the Vertical Speed Hold mode. When pressed with altitude displayed, will engage the Vertical Speed Hold mode and re-sync the Vertical speed Hold mode to the current vertical speed of the airplane.
- Item 2 - **PHOTOCELL**
Automatically dims display according to the cockpit ambient light.

- Item 3 - VERTICAL SPEED (VS) ANNUNCIATOR
Illuminates when the Vertical Speed Hold mode is engaged.
- Item 4 - VERTICAL SPEED UP / DOWN CARETS (^ or v)
Indicates whether the selected vertical speed is up or down.
- Item 5 - GAS DISCHARGE DISPLAY
Displays selected altitude from 100 to 35000 feet or the selected vertical speed from 0 to 3000 ft per minute up or down.
- Item 6 - ALTITUDE ALERT (ALERT) ANNUNCIATOR
The ALERT annunciator is illuminated 1000 ft prior to the selected altitude, goes out 300 ft prior to the selected altitude and illuminates momentarily when the selected altitude is reached. Once the selected altitude is reached, the light signifies that the 300 ft "safe band" has been exceeded and will remain on until 1000 ft from the selected altitude. The alert light is accompanied by a 2 second, pulsating aural tone anytime the light initially comes on.
- Item 7 - VERTICAL SPEED / ALTITUDE SELECT KNOB
Concentric knobs which allow easy setting of altitude or vertical speed. The small knob (inner) has an IN and OUT position.
Altitude is displayed and selected when the small knob is in the IN position. When rotated the small knob selects altitude in 100 foot increments with roll over into the 1000 digits. The larger knob (outer) selects altitude in 1000 foot increments with roll over into the 10000 digits.
Vertical speed is displayed and selected when the small knob is in the OUT position. When rotated the small knob selects vertical speed in 100 ft / min increments.
The larger knob selects vertical speed in 1000 ft / min increments up to a maximum of 3000 ft / min.

- Item 8 - **MODE (FT or FT / MIN) ANNUNCIATOR**
Indicates FT / MIN when in the Vertical Speed Hold mode and FT when in the Altitude Select mode.
- Item 9 - **ALTITUDE CAPTURE (CAPT) ANNUNCIATOR**
Indicates the KAS 297C has switched the autopilot from Pitch Attitude Hold or Vertical Speed Hold mode into the pitch roundout mode (CAPT). The point, just prior to transfer into Altitude Hold, at which the CAPT mode becomes active varies with the vertical speed, i.e. the higher the rate of climb, the sooner the CAPT mode becomes active ; at low rates of climb the activation of the CAPT mode and transfer to altitude hold occur almost simultaneously. Engagement of any vertical mode or use of vertical trim, when in CAPT mode, will cancel this mode.
- Item 10 - **ALTITUDE SELECT MODE (ARM) ANNUNCIATOR**
Indicates that the Altitude Select mode is armed to capture the selected altitude.
- Item 11 - **ALTITUDE SELECT MODE (ARM) BUTTON**
When pressed and the selected altitude is displayed, will arm the Altitude Select mode. The Altitude Select (ARM) mode will cancel altitude hold (ALT) if ALT is already engaged. If Altitude Select (ARM) mode is present when GS couple occurs, the GS mode will cancel Altitude Select (ARM) mode. The engagement of ALT by the pilot's use of the ALT switch will cancel the altitude Select (ARM) mode.
- Item 12 - **CONTROL WHEEL STEERING (CWS) BUTTON (Not shown) -**
When pressed, in addition to the normal autopilot functions, the CWS also interfaces with the KAS 297C. When operating in the Vertical Speed Hold mode, the CWS will re-sync the vertical Speed Hold mode to the current vertical speed of the airplane. If altitude is displayed when the CWS is pressed, the display will automatically display vertical speed as long as the CWS is depressed. CWS does not affect the Altitude Select mode.

7.2 - KMC 321 CONTROL BOX

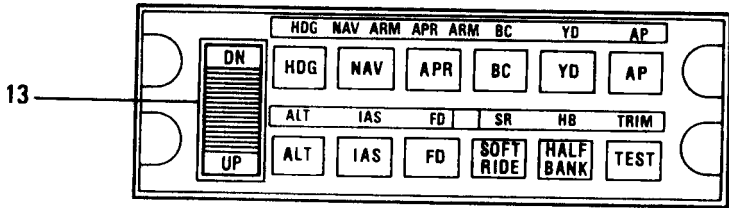

5.4.700.22.0016

Figure 9.2.2 - KMC 321 CONTROL BOX

Item 13 - VERTICAL TRIM CONTROL

When in the Vertical Speed Hold mode this control can be used to slew the vertical speed up or down at 100 ft / min for every second the rocker switch is held down. If altitude is being displayed at the time the rocker switch is depressed, vertical speed will be displayed until 1 - 2 seconds after the rocker switch is released.

7.3 - CIRCUIT-BREAKERS

Autopilot components are supplied through following circuit-breakers :

<u>LABEL</u>	<u>FUNCTION</u>
AP / TRIMS	Supplies power to the KCP 220, the autopilot pitch, roll and yaw servos and the "PITCH TRIM", "AIL TRIM", "RUD TRIM" and "AP DISC" circuit-breakers.
AP ALERT	Supplies power to the KAA 15 audible alarm.
AP ALT SEL	Supplies power to the KAS 297C.
HSI RMI	Supplies the compass system.
PITCH TRIM	Supplies power to the manual electric pitch trim.
AP DISC	Delivers a control signal (28 VDC switched by "AP DISC TRM INT" switch) to the KCP 220 autopilot computer and to the KAA 15 alarm unit.

INTENTIONALLY LEFT BLANK

SUPPLEMENT

"BFG" WX-500 OR WX-950 OR WX-1000 OR 1000+ OR 1000E STORMSCOPE

TABLE OF CONTENTS

	Page
1 - GENERAL	9.6.2
2 - LIMITATIONS	9.6.2
3 - EMERGENCY PROCEDURES	9.6.3
4 - NORMAL PROCEDURES	9.6.4
5 - PERFORMANCE	9.6.4
6 - WEIGHT AND BALANCE	9.6.5
7 - DESCRIPTION	9.6.7

"BFG" **STORMSCOPE****SECTION 1****GENERAL**

This supplement supplies information to the pilot about limitations, normal and emergency procedures when the optional "BFG" WX-500 or WX-950 or WX-1000 or 1000+ or 1000E stormscope is installed on the TBM airplane. The stormscope must be used within limits of this supplement.

SECTION 2**LIMITATIONS**

These limitations supplement those of standard airplane described in Section 2 "Limitations" of the basic Pilot's Operating Handbook.

The "BFG" stormscope systems signal displays are not intended for the purpose of penetrating thunderstorm areas or areas of severe turbulence ; such intentional use is prohibited.

NOTE :

Range selection determines receiver sensitivity and therefore relative range. Displayed range is based on signal strength and is not to be used for accurate determination of thunderstorm location.

WX-1000 or 1000+ or 1000E

The "BFG" stormscope checklist functions are for reference only.

All**CAUTION**

**THE STORMSCOPE MUST NOT BE USED FOR THUNDERSTORM
PENETRATION**

- The Stormscope "BFG" Pilot's Handbook, Series II, No. 75-0299-7690-1 (WX-1000 or 1000+ or 1000E),
or
- The WX-950 Pilot's guide, Series II, No. 009-10951-001,
or
- The WX-500 Pilot's guide, Series II, No. 009-11501-001 and the "GARMIN" GNS 530 Pilot's Guide, No. 190-00181-00,
or
- The WX-500 Pilot's guide, Series II, No. 009-11501-001 and the "HONEYWELL" KMD 550/850 Pilot's Guide P/N 006-18222-0000,
or
- The WX-500 Pilot's guide, Series II, No. 009-11501-001 and the "GARMIN" GMX 200 Pilot's Guide, No. 190-00607-02,
or
Post-MOD70-0176-00
- The WX-500 Pilot's guide, Series II, No. 009-11501-001 and the "GARMIN" G1000 Integrated Flight Deck Cockpit Reference Guide for the Socata TBM 850, No. 190-00708-00,

at their last revision, shall be readily available to the pilot, each time the "BFG" stormscope operation is foreseen.

SECTION 3

EMERGENCY PROCEDURES

Installation and operation of "BFG" stormscope do not change the basic emergency procedures of the airplane described in Section 3 "Emergency procedures" of the basic Pilot's Operating Handbook.

SECTION 4

NORMAL PROCEDURES

Normal operating procedures of the "BFG" stormscope are outlined in :

- the Pilot's Handbook, Series II, No. 75-0299-7690-1 at its last revision for "BFG" stormscope model WX-1000 or 1000+ or 1000E
or
- the WX-950 Pilot's Guide, Series II, No. 009-10951-001 at its last revision for "BFG" stormscope model WX-950
or
- the WX-500 Pilot's Guide, Series II, No. 009-11501-001 at its last revision for "BFG" stormscope model WX-500.

SECTION 5

PERFORMANCE

Installation and operation of "BFG" stormscope do not change the basic emergency procedures of the airplane described in Section 5 "Performance" of the basic Pilot's Operating Handbook.

SECTION 6 WEIGHT AND BALANCE

Informations hereafter supplement the ones given for the standard airplane in Section 6 "Weight and balance" of the basic Pilot's Operating Handbook.

A or O	OPTIONAL EQUIPMENT	EQUIPMENT SUPPLIER	WEIGHT per unit lb (kg)	ARM in. (m)
	34 - NAVIGATION			
A	Stormscope (OPT 70 34009A) WX-1000+	BFG	16.535 (7.500)	228.35 (5.800)
A	Stormscope (OPT 70 34009B) WX-1000	BFG	15.432 (7.000)	230.71 (5.860)
A	Stormscope EFIS coupled (OPT 70 34009C) WX-1000+	BFG	15.432 (7.000)	230.71 (5.860)
A	Stormscope EFIS coupled - Remote installed control (OPT 70 34009D) WX-1000E	BFG	9.502 (4.310)	269.09 (6.835)
A	Stormscope EFIS coupled (OPT 70 34009E) WX-1000E	BFG	15.939 (7.230)	230.94 (5.866)
A	Stormscope shared with the SKYWATCH (OPT 70 34009F) WX-1000E	BFG	15.939 (7.230)	230.94 (5.866)
A	Stormscope shared with the SKYWATCH (OPT 70 34009G) WX-1000+	BFG	16.535 (7.500)	228.35 (5.800)
A	Stormscope (OPT 70 34041) WX-950	BFG	4.696 (2.130)	191.85 (4.873)

A or O	OPTIONAL EQUIPMENT	EQUIPMENT SUPPLIER	WEIGHT per unit lb (kg)	ARM in. (m)
A	Stormscope WX-500 - shared with the GNS 530 GPS or with the KMD 850 or GMX 200 MFD (OPT 70 34056A)	BFG	4.94 (2.240)	232.28 (5.900)
A	Stormscope WX-500 - shared with the GARMIN G1000 system (OPT 70 34056B)	BFG	4.94 (2.240)	232.28 (5.900)

SECTION 7
DESCRIPTION

The "BFG" (Series II) stormscope, weather mapping system provides a visual screen readout of the electrical discharges associated with thunderstorms. This information with proper interpretation, will allow the pilot to detect severe thunderstorm activity. A series of green dots or of strike points will be displayed on the screen to indicate the electrical discharge areas.

Dots or strike points may be displayed on two selectable views : 360° view of surrounding airspace and 120° view of forward airspace only.

The display scope provides full scale selectable ranges of 200, 100, 50 and 25 NM.

■ Post-MOD70-125-23 and Pre-MOD70-0176-00

Stormscope setting to ON or OFF is performed by using the "RADIO MASTER" switch.

INTENTIONALLY LEFT BLANK

SUPPLEMENT
"BENDIX / KING"
EFS 40

TABLE OF CONTENTS

	Page
1 - GENERAL	9.9.2
2 - LIMITATIONS	9.9.2
3 - EMERGENCY PROCEDURES	9.9.4
4 - NORMAL PROCEDURES	9.9.11
5 - PERFORMANCE	9.9.17
6 - WEIGHT AND BALANCE	9.9.17
7 - DESCRIPTION	9.9.18

SECTION 1

GENERAL

This supplement provides information necessary for airplane utilization when the system EFIS "BENDIX / KING" EFS 40 type is installed on TBM 700 airplane.

SECTION 2

LIMITATIONS

These limitations supplement those of standard airplane described in Section 2 "Limitations" of the basic Pilot's Operating Handbook.

The installation of EFS 40 EFIS is subordinated to the installation of the modification Nr MOD 70-010-24 "Alternator Ventilation".

The using of COMPOSITE MODE is only authorized when one of both displays is out of order or when ventilation of one of both displays is out of order.

To undertake an IFR-flight :

- The EADI and EHSI must be available.
- The stand-by horizon must be available.
- No red or yellow "SG" or "DU" warning must be present.
- The "CHECK CONFIG" warning must not be present.
- ATTITUDE FAIL and HDG warnings must not be present.

CAUTION

EFS 40 CONFIGURATION OF THE TBM 700 AIRPLANE IS MENTIONED ON FIGURE 9.9.1. MODIFICATION OF THIS CONFIGURATION IS PROHIBITED

1	VIEW / EDIT OPERATING CHAR			
2	ITEM	SG	RK1	RK2
4	DCLTR GS ON BC	1	1	1
6	DISPLAY WIND VEC	1	1	1
7	DISPLAY DRIFT	1	1	1
9	DME DIST ONLY	1	1	1
1	VIEW / EDIT OPERATING			
2	ITEM	SG	RK1	RK2
6	DCLTR UNUS ATT	1	1	1
1	VIEW / EDIT OPERATING			
2	ITEM	SG	RK1	RK2
4	VERT PTR TYPE	2	2	2
5	DISPLAY FMS MSG	1	1	1
9	RISING RUNWAY	1	1	1
11	CMD BAR FILTER	1	1	1

NOTE :

Confirm all missing lines above mentioned as follows :

SG	RK1	RK2
0	0	0

Figure 9.9.1 - TABLE OF OPERATING CONFIGURATIONS CERTIFIED FOR TBM 700 AIRPLANE

The "BENDIX / KING Pilot's Guide EFS 40 system" P/N 006-08701-00001K at its latest revision shall be readily available for the operation of the EFIS.

SECTION 3
EMERGENCY PROCEDURES

These procedures supplement those of standard airplane described in Section 3 "Emergency procedures" of the basic Pilot's Operating Manual.

TABLE OF CONTENTS OF EMERGENCY PROCEDURES

	Page
TRANSITION TO COMPOSITE MODE	9.9.5
RED WARNING ATTITUDE FAIL	9.9.6
RED WARNING HDG	9.9.6
EADI FAILURE	9.9.7
EHSI FAILURE	9.9.7
YELLOW WARNING DU	9.9.7
YELLOW WARNING SG	9.9.8
RED WARNING CP	9.9.8
SELF-TEST DISPLAY	9.9.8
RED CROSS DISPLAY ON HEADING BUG	9.9.9
RED CROSS DISPLAY ON COURSE POINTER	9.9.9
RED WARNING RCP	9.9.9
RED WARNINGS ATTITUDE FAIL AND HDG	9.9.10
SMALL RED WARNING SG	9.9.10
BIG RED WARNING SG	9.9.10
YELLOW WARNING ↔ HDG	9.9.10A

TRANSITION TO COMPOSITE MODE**CAUTION**

THE USE OF COMPOSITE MODE IS ONLY AUTHORIZED WHEN ONE OF BOTH DISPLAYS IS OUT OF ORDER OR WHEN VENTILATION OF ONE OF BOTH DISPLAYS IS OUT OF ORDER

- 1 - Control the attitudes referring to stand-by horizon
- 2 - Select COMPOSITE MODE by pressing CMPST push-button
When COMPOSITE figuration appears :
- 3 - Fully reduce brightness of the faulty display
- 4 - Control referring to the remaining display

CAUTION

THE AUTOPILOT DISENGAGES AS SOON AS COMPOSITE MODE IS SELECTED. AS SOON AS COMPOSITE FIGURATION APPEARS, THE AUTOPILOT CAN BE REENGAGED

RED WARNING

ATTITUDE FAIL

This warning, displayed on EADI center, indicates a vertical gyro failure. It causes pitch and roll attitudes scales removal and involves autopilot disconnection.

- Control the attitude referring to stand-by horizon.

RED WARNING

HDG

This warning, displayed on EHSI lubber line indicator location, indicates a directional gyro failure. It involves autopilot transition to wings level basic mode.

- Control the heading referring to emergency compass.

NOTE :

- . *Only bearing information remains valid for ADF.*
- . *Only QDM and course deviation information remain valid for the VOR.*

EADI FAILURE

If EADI symbols partially or completely disappear, the display is out of order.

In order to reconfigure the system, apply transition to COMPOSITE MODE procedure.

EHSI FAILURE

If EHSI symbols partially or completely disappear, the display is out of order.

In order to reconfigure the system, apply transition to COMPOSITE MODE procedure.

YELLOW WARNING**DU**

This warning, displayed on the lower left corner of the EADI or EHSI, indicates a loss of airflow of the concerned display.

- If the failure occurs **BEFORE FINAL APPROACH PHASE**, apply transition to COMPOSITE MODE procedure.
- If the failure occurs **DURING FINAL APPROACH**, continue without changing anything.

NOTE :

In the worst ambient temperature conditions, the display correctly operates during at least 30 minutes after annunciation.

YELLOW WARNING

SG

This warning, displayed on the lower left corner of the EADI and at the lower right corner of the EHSI, indicates a loss of airflow of the symbol generator.

- 1- Reduce, if possible, displays brightness
- 2- Lighten the display information if possible (radar image, navigation secondary information)

NOTE :

In the worst ambient temperature conditions, the symbol generator correctly operates during at least 30 minutes after annunciation.

RED WARNING

CP

This warning, displayed on the L.H. of the EHSI and at the lower left corner of the EADI, indicates that a control panel switch of the EHSI has become stuck.

In this case, **ALL CURRENTLY SELECTED CONDITIONS ARE FROZEN.**

SELF-TEST DISPLAY

A self-test display during the flight indicates :

- that the pilot pressed the TST / REF push-button during more than 3 seconds,
- or that the TST / REF push-button remained stuck after having been briefly depressed.

In the case of a stuck button, the EADI and the EHSI return to normal display after 6 seconds.

**RED CROSS DISPLAY ON
HEADING BUG**

A red cross, displayed on the HEADING BUG, indicates a HDG rotactor failure.

In this case, THE HEADING SELECTION IS FROZEN.

**RED CROSS DISPLAY ON
COURSE POINTER**

A red cross, displayed on head and tail of the COURSE pointer, indicates a CRS rotactor failure.

In this case, THE COURSE SELECTION IS FROZEN.

RED WARNING**RCP**

This warning, displayed on the lower left corner of the EHSI, indicates a radar control panel failure.

NOTE :

In case of absence of specific radar screen, the radar goes automatically into ST-BY mode, regardless of radar control panel setting, whenever a weather radar mode is not selected for EHSI.

RED WARNINGS

ATTITUDE FAIL

AND

HDG

These warnings indicate a failure of directional and vertical gyros power supply converter.

It involves autopilot disconnection as well as the removal of ADF information.

- Control referring to emergency instruments.
- Set "EFIS MASTER" switch to OFF.

SMALL RED WARNING

SG

This warning, displayed on EHSI upper part or on EADI lower part, indicates that information present on the concerned display are no longer valid.

- Use these information, particularly the attitudes, only after validation with emergency instruments and only as additional information.

BIG RED WARNING

SG

This warning, displayed on the entire EADI or EHSI screen, indicates that the symbols generator of the concerned display is unusable. It involves the autopilot disconnection.

- Control referring to corresponding emergency instruments.
- Fully reduce brightness of the concerned display.

OPTION OPT70-01-018 (if installed)

YELLOW WARNING

HDG

This warning displayed on the L.H. side of the heading bug, indicates a heading difference greater than 6° between the EHSI and HSI#2 directional gyros.

- Determine the wrong heading source by referring to a 3rd heading source.

INTENTIONALLY LEFT BLANK

SECTION 4
NORMAL PROCEDURES

4.1 - GENERAL

These procedures supplement those of standard airplane described in Section 4 "Normal procedures" of the basic Pilot's Operating Handbook.

4.2 - LIST OF GROUND CHECKS

BEFORE TAXIING	
1 - Check no flags "DU", "SG", "CP"	
EFS 40 SYSTEM AUTOTEST (if desired)	
1 - "TST / REF" button	PRESS and HOLD for 3 seconds
2 - Check :	
- the EHSI and EADI test images appear	
- the "SELF TEST PASS" or "SELF TEST FAIL" message is annunciated in the center of each test pattern	
If the "SELF TEST FAIL" message appears, the EFS 40 system must be serviced.	

4.3- LIST OF INFLIGHT CHECKS

SELECTION OF NAVIGATION SYSTEM

1 - Push-button

1
2

 PRESS

NOTE :

If only one navigation sensor is installed, the display will not cycle and the sensor annunciation will not show a system number.

SELECTION OF THE PRIMARY NAVIGATION SENSOR

1 - Push-button

N
A
V

 PRESS

A press of the NAV push-button sequentially selects the primary navigation sensor. The sequence movement is :

- VOR, LOR (if installed), ADF then VOR, etc...

NOTE :

When the VOR navigation sensor is selected and an ILS frequency displayed, or if the KNS 81 is in RNAV mode, the VOR annunciation is respectively replaced by LOC or RNAV.

SELECTION OF THE 360-DEGREE HSI MODE

1 - Push-button

H
S
I

 PRESS

A press of the HSI push-button, sequentially selects the 360-degree display formats. The movement sequence is :

- COMPASS ROSE
- COMPASS ROSE AND NAVIGATION MAP
- COMPASS ROSE AND NAVIGATION MAP AND RADAR IMAGE (if radar installed)

SELECTION OF BEARING POINTERS

1 - Push-button

→

 or

⇒

 PRESS

The button

→

 is paired with the white single bar pointer.

The button

⇒

 is paired with the magenta double bar pointer.

A press of the bearing pointer buttons, sequentially selects the navigation sensors which are interfaced with the pointers.

The movement sequence is :

- no pointer (declutter function)
- VOR
- LOR (if installed)
- ADF
- no pointer, etc...



SELECTION OF BEARING POINTERS (Cont'd)

NOTE :

- *The pointers are displayed only if a valid radio-electric information exists.*
- *The VOR position is withdrawn from the sequence if an ILS frequency is selected.*
- *The DME information is displayed below the sensor annunciation - in VOR function, if a VOR-DME frequency is selected - in ADF function, if a VOR-DME frequency is selected and the DME positioned to "HOLD".*
- *The distance indication is displayed only if a valid DME signal is really received.*

SELECTION OF THE "ARC" DISPLAY MODE

1 - Push-button

A
R
C



 PRESS

A press of the ARC push-button, sequentially selects the ARC display formats. An approximate 85-degree sector display of the compass is presented. The movement sequence is :

ARC - ARC + NAV - ARC + NAV + RADAR (if installed) -
ARC + RADAR (if installed) - ARC...

RANGE SELECTION

- 1- Push-button  or  **PRESS**

A press of the buttons  or  respectively selects the next higher or lower range to be displayed while in the NAV MAP or RADAR modes of operation. The selectable ranges are :

5 NM - 10 NM - 20 NM - 40 NM - 80 NM - 160 NM - 240 NM - 320 NM - 1000 NM.

COURSE SELECTION

- 1-  CRS knob **ROTATE**

Pushing the center of the  CRS knob will cause the course pointer to slew to the direct course to the selected NAVAID or active waypoint.

HEADING SELECTION

- 1-  HDG knob **ROTATE**

Pushing the center of the  HDG knob will cause the heading bug to slew to the present aircraft heading.

SETTING OF GROUND SPEED OR TIME TO THE STATION

1 - TST / REF button **PRESS**

When the EFIS system is coupled with the KLN 90A or KLN 90B GPS, a press of the TST / REF button displays one after the other in NAVIGATION MAP mode the following items on the screen background :

- FPL ID
- AIRPORT
- NAVAIDS.

CAUTION

WHEN THE TST / REF BUTTON IS PRESSED AND HELD FOR 3 SECONDS, IT INITIATES THE EFS 40 SYSTEM TEST AND DISENGAGES THE AUTOPILOT

**SECTION 5
PERFORMANCES**

The installation and the operation of "BENDIX/KING" EFS 40 system do not change the basic performance of the airplane described in Section 5 "Performance" of the basic Pilot's Operating Handbook.

**SECTION 6
WEIGHT AND BALANCE**

Information hereafter supplement the one given for the standard airplane in Section 6 "Weight and balance" of the basic Pilot's Operating Handbook.

A or O	OPTIONAL EQUIPMENT	EQUIPMENT SUPPLIER	WEIGHT per unit lb (kg)	ARM in. (m)
	01 – SPECIFIC OPTIONAL EQUIPMENT			
A	Heading#1/Heading#2 EHSI miscompare (OPT70 3401018)	KING	0.033 (0.015)	125.98 (3.200)
	34 – NAVIGATION			
O	EFIS (EFS 40 + AP) KFC 325 (OPT 70 34001) – with standby horizon M32 RC ALLEN RCA 22 – with horizon M32 EDO AIRE /SIGMATEK 5000B	KING	71.716 (32.530) 71.520 (32.440)	133.19 (3.383) 132.60 (3.368)

SECTION 7 DESCRIPTION

7.1 - EFS 40 CONTROLS

- 1) EADI
- 2) EHSI
- 3) Push-button of EFS 40 self-test or of DME ground speed or time-to-station alternate display
- 4) Scale setting push-button in MAP or WEATHER mode
- 5) ARC symbologic mode selecting push-button
- 6) Selected heading bug knob
- 7) ERMI dual pointer selecting push-button
- 8) EHSI brightness setting knob
- 9) ERMI single pointer selecting push-button
- 10) Navigation course selecting knob
- 11) EHSI figuration modes selecting push-button
- 12) Navigation source selecting push-button
- 13) Navigation system selecting push-button
- 14) MARKER test and level selecting toggle switch
- 15) EADI brightness setting knob
- 16) COMPOSITE MODE selecting push-button
- 17) CMPST push-button light test
- 18) DME frequency tuning selecting rotary switch
- 19) EFIS MASTER switch - see Figure 9.9.4

Figure 9.9.2 (1 / 2) - CONTROLS AND DISPLAY

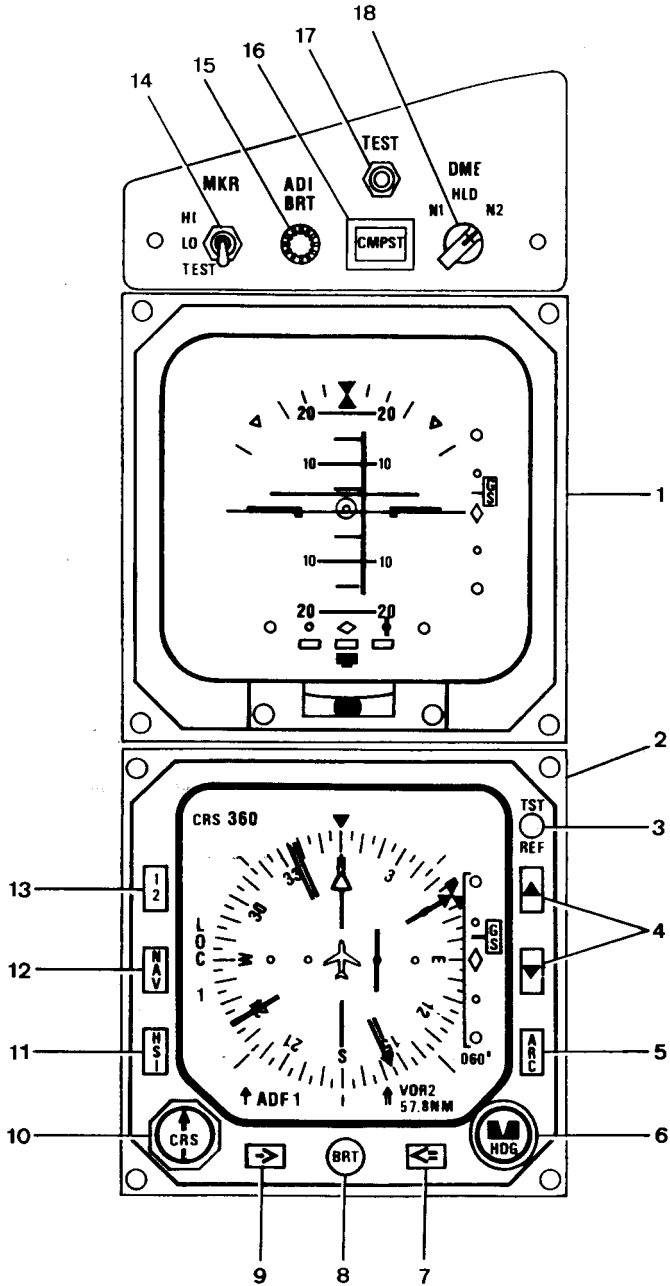

S-4.700.34.0010

Figure 9.9.2 (2 / 2) - CONTROLS AND DISPLAY

- Item 3 - TST / REF button - It allows to self-test the EFS 40 system by pressing at least 3 seconds. A brief switching allows to alternately display DME ground speed or time-to-station.
- Item 4 - PUSH-BUTTON Δ and ∇ - They allow to modify the range scale either in NAV MAP or WEATHER mode.
- Item 5 - ARC PUSH-BUTTON - It allows to select the desired ARC figuration :
by switching :
 - . ARC COMPASS ROSE
 - . ARC NAV MAP
 - . ARC NAV MAP WITH WEATHER
 - . ARC COMPASS ROSE WITH WEATHER
- Item 6 - HDG KNOB - It allows to set the bug to the desired heading. Depress to synchronise with the present heading.
- Item 7 - PUSH-BUTTON \leq - It allows to allocate the ERMI dual pointer to the different navigation sensors.
- Item 8 - BRT KNOB - It allows to set the EHSI brightness.
- Item 9 - PUSH-BUTTON \rightarrow - It allows to allocate the ERMI single pointer to the different navigation sensors.
- Item 10 - CRS KNOB - It allows to display the desired radial.
Depress to select the present QDM.
- Item 11 - HSI PUSH-BUTTON - It allows to select the EHSI desired figuration :
by switching :
 - . HSI COMPASS ROSE
 - . HSI NAV MAP
 - . HSI NAV MAP WITH WEATHER
- Item 12 - NAV PUSH-BUTTON - It allows to select the primary navigation source.
- Item 13 - NAVIGATION SYSTEM SELECTING PUSH-BUTTON - It allows to select the navigation system used (system 1 or 2).

Figure 9.9.3 (1 / 2) - EHSI CONTROLS

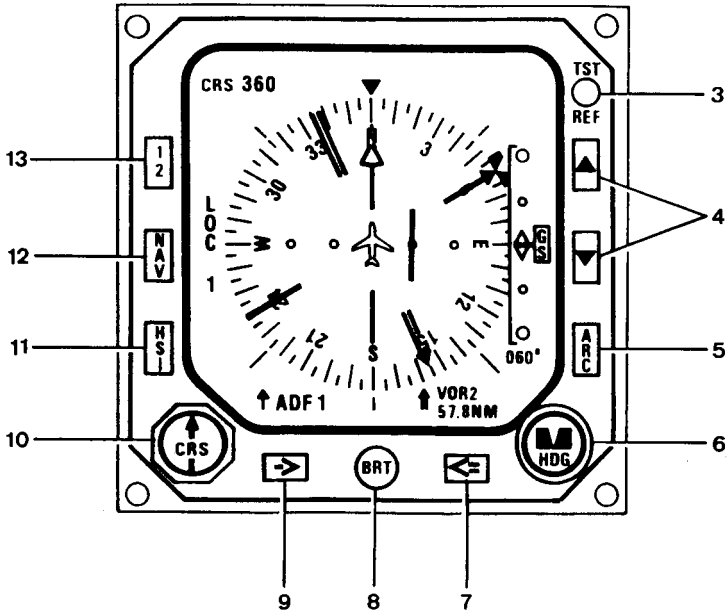

S-4-700-34-0011

Figure 9.9.3 (2 / 2) - EHSI CONTROLS

- Item 14 - MKR TOGGLE - It allows to test the Marker system (TEST) and select the receiver sensitivity (LO, HI).
- Item 15 - ADI BRT KNOB - EADI display brightness setting knob.
- Item 16 - CMPST PUSH-BUTTON - Push-button allowing to select COMPOSITE MODE figuration, which is an image uniting EADI display information with some navigation information including a heading scale along the horizon line.
- Item 17 - TEST PUSH-BUTTON - It allows to test the CMPST push-button lamp.
- Item 18 - DME ROTARY SWITCH - It allows to tune DME receiver frequency to the navigation system 1 or 2 (N_1 and N_2 positions). Furthermore, when tuning is performed, the rotator allows to memorize the selected frequency in the DME receiver (HLD position).
- Item 19 - EFIS MASTER SWITCH - It controls the power to all EFIS system components.

Figure 9.9.4 (1 / 2) - EADI CONTROLS

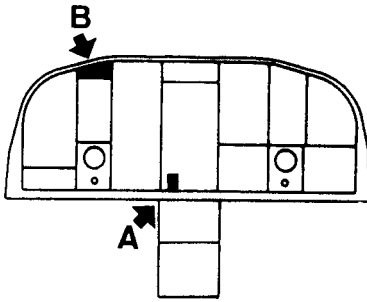

(A)

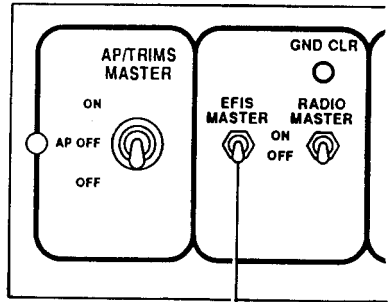

19

(B)

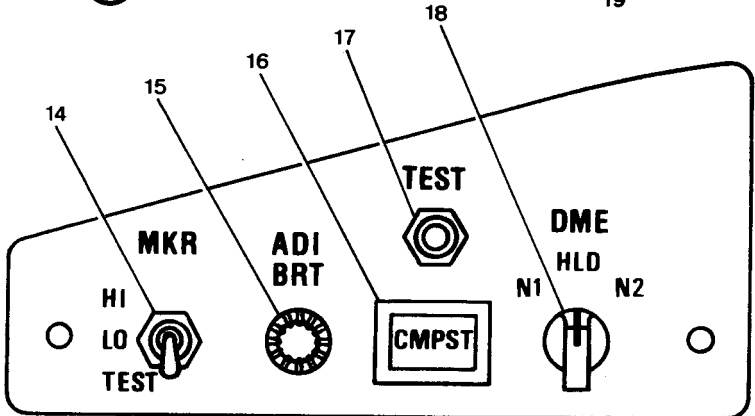

S4342800AAAEMAFM00

Figure 9.9.4 (2 / 2) - EADI CONTROLS

INTENTIONALLY LEFT BLANK

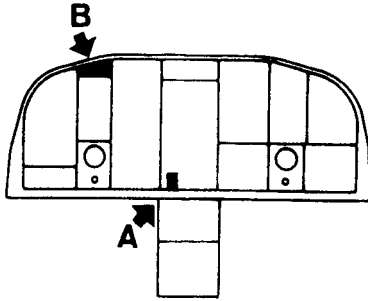

(A)

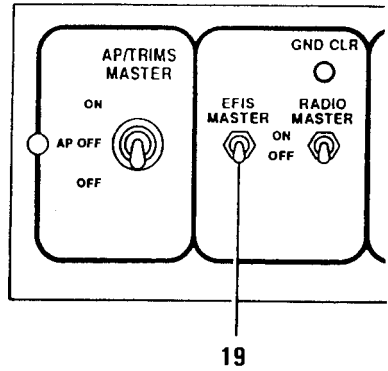

(B)

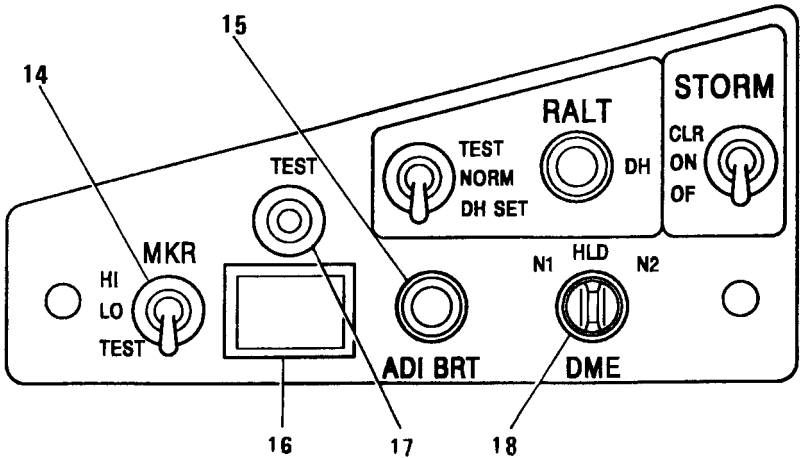

S4342800AAAFMAFM00

Figure 9.9.4A (2 / 2) - EADI CONTROLS

7.2 - EADI SYMBOLOGY

- 1) Roll scale
- 2) Pitch scale
- 3) Airplane symbol (for split-cue FD command bars)
- 4) Side-slip indicator
- 5) Radar altimeter display
- 6) Glide Slope scale
- 7) Decision height alert
- 8) Airplane symbol (for single-cue FD command bars)
- 9) Localizer scale
- 10) Selected decision height display
- 11) Rate of turn display
- 12) FD command bars (split-cue)
- 13) Autopilot modes annunciator
- 14) FD command bars (single-cue)

Figure 9.9.5 (1 / 2) - EADI

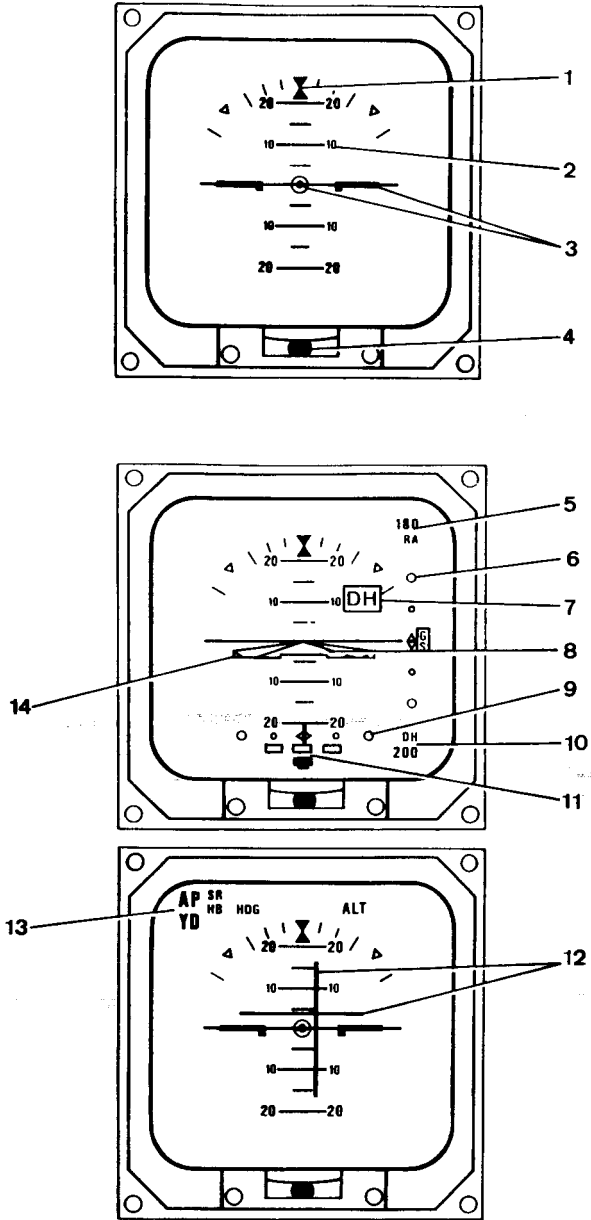

S-4.700.34.0013

Figure 9.9.5 (2 / 2) - EADI

7.3 - EHSI SYMBOLOGY

- 1) Selected course
- 2) Lubber line
- 3) Selected heading bug
- 4) Distance bound to the primary navigation source (or other navigation system when in HLD function)
- 5) Ground speed or time-to-station or navigation source frequency when in HLD function
- 6) Glide Slope scale
- 7) Glide Slope pointer
- 8) Selected heading value
- 9) Heading rose
- 10) ERMI dual pointer
- 11) DME 2 distance
- 12) Navigation system allocated to ERMI dual pointer
- 13) DME 1 distance
- 14) Navigation system allocated to ERMI single pointer
- 15) ERMI single pointer
- 16) Deviation bar
- 17) Navigation system Nr 1 or Nr 2 used
- 18) Primary navigation source selected
- 19) Airplane symbol
- 20) Selected radial pointer

Figure 9.9.6 (1 / 2) - STANDARD EHSI SYMBOLOGY

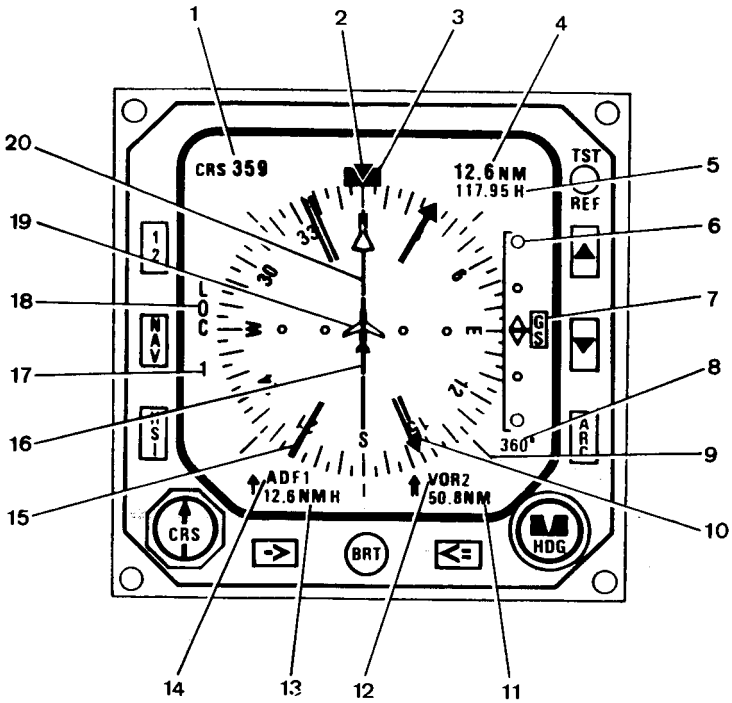

S.4.700.34.0014

Figure 9.9.6 (2 / 2) - STANDARD EHSI SYMBOLOGY

AP / TRIMS	AP & trims general protec.	ADVISORY 1	Visual warn. protec.
RUD TRIM	Rudder trim protec.	ADVISORY 2	Visual warn. protec.
AIL TRIM	Aileron trim protec.	AUDIO WARN	Audio warnings protec.
PITCH TRIM	Pitch trim protec.	FLAPS SIG	Flaps signalization protec.
FLAPS	Flaps protec.	LDG GR CONT	Landing gear control protec.
LDG GR	Landing gear general protec.	LDG GR SIG	Landing gear signalization protec.
ESS BUS TIE	Essential bus NORM & EMER switch	AP DISC	Trim and AP cont. protec.
PITOT 1 HTR	Pitot 1 deicing protec.	AP ALERT	Trim and AP audio signalization protec.
PITOT 2 & STALL HTR	Pitot 2 and stall warning deicing protec.	AP ALT SEL	Altitude selector protec.
INERT SEP	Inertial separator protec.	ESS BUS 1	Essential bus 1 circuit protec.
LW/S DE ICE	L.H. windshield deicing protec.	ESS BUS 2	Essential bus 2 circuit protec.
RW/S DE ICE	R.H. windshield deicing protec.	EHSI	EHSI protec.
PROP DE ICE	Propeller deicing protec.	EADI	EADI protec.
AIRFRAME DE ICE	Empennage and wing leading edges deicing protec	GYRO	Gyros protec.
ICE LIGHT	L.H. wing leading edge lighting protec.	RMI	RMI protec.
L LDG	L.H. landing light protec.	ADI 2	ADI Nr 2 protec.
TAXI	Taxi light protec.	PHONES	Reception line protec.
R LDG	R.H. landing light protec.	SPKR	Loudspeaker line protec.
NAV	Navigation lights protec.	COM 1	VHF 1 protec.
STROBE	Strobe lights protec.	GND CLR	Ground communication protec.
CABIN	Passenger's reading lamps protec.	NAV 1	NAV 1 radio protec.
ACCESS	FWD dome light, cabin, baggage compartment bottom & access door lighting protec.	COM₂ NAV	VHF 2 & NAV 2 radio protec.
INSTR	Instruments light. protec.	ENCOD ALTI	Encoding altimeter protec.
PANEL NORM	Instrument panel normal lighting protec.	XPDR	Transponder protec.
PANEL EMER	Instrument panel emergency lighting protec.	RMI 2	RMI 2 protec.
FUEL GAGE 1	L.H. gage protec.	RADIO FAN	Radio fan protec. + radio master
FUEL GAGE 2	R.H. gage protec.	ADF	ADF protec.
FUEL SEL	Timer protec.	DME	DME protec.
AUX BP	Fuel pump protec.	MKR	MKR protec.
MEMORY & CLOCK	Stop watch and flowmeter protec.	STORM	Stormscope protec.
ENGINE INDIC 1	Power plant cont. protec. : Oil temp. & pres., torque, propeller	WSR	Weather radar protec.
ENGINE INDIC 2	Power plant cont. protec. : Ng, flowmeter & ITT	GC	Radar graphic protec.
IGNIT	Power plant ignit. protec.	LRN	LORAN long range navigation protec.
		CABIN BLEED	Cabin air bleed valve protec.
		CABIN TEMP	Cabin temperature valve protec.
		FAN	Ground fan protec.

Figure 9.9.7 (1 / 2) - EFIS CIRCUIT BREAKERS PANEL

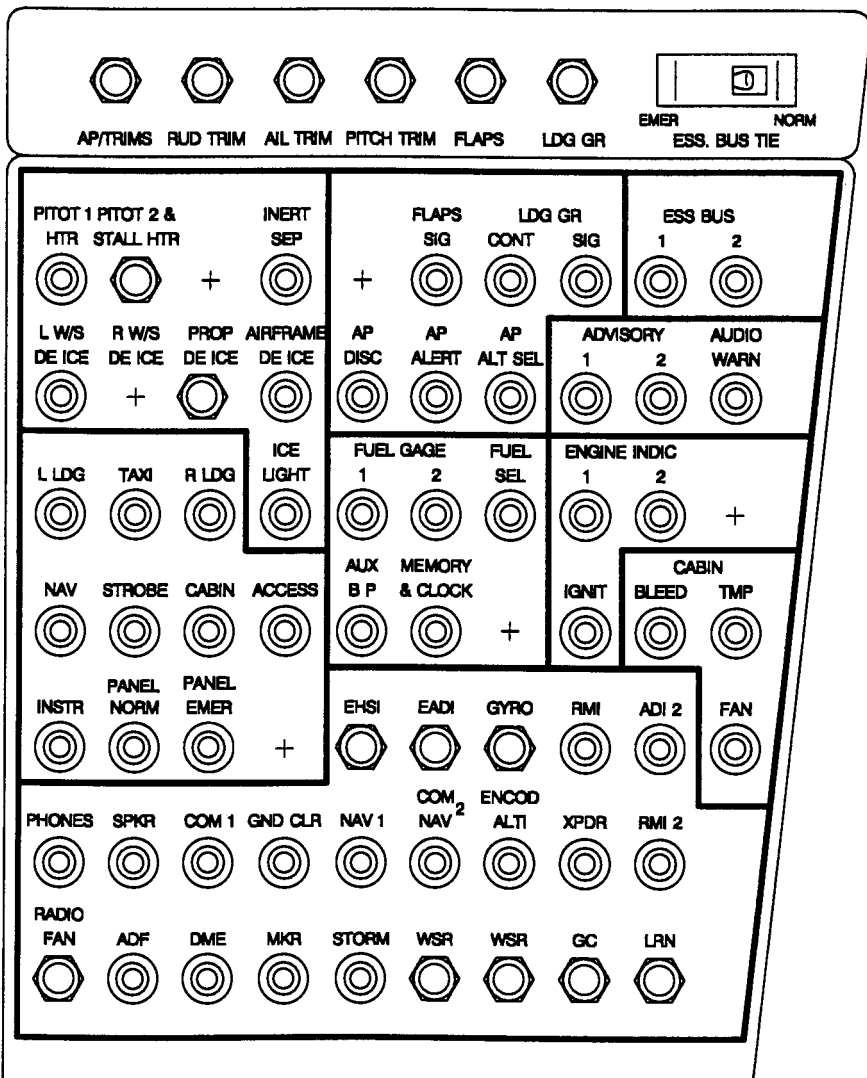

14255004AAA1HMA8201



-  Disjoncteur déclenchable
"PULL-OFF" type circuit breaker
-  Disjoncteur non déclenchable
Circuit breaker which cannot be pulled off

Figure 9.9.7 (2 / 2) - EFIS CIRCUIT BREAKERS PANEL

AP / TRIMS	AP & trims general protec.	FUEL GAGE 1	L.H gage protec.
RUD TRIM	Rudder trim protec.	FUEL GAGE 2	R.H gage protec.
AIL TRIM	Aileron trim protec.	FUEL SEL	Timer protec.
PITCH TRIM	Pitch trim protec.	AUX BP	Fuel pump protec.
FLAPS	Flaps protec.	ENGINE INDIC 1	Power plant cont. protec. : Oil temp. & pres., torque, propeller
LDG GR	Landing gear general protec.	ENGINE INDIC 2	Power plant cont. protec. : Ng, flowmeter & ITT
ESS BUS TIE	Essential bus NORM &	IGNIT	Power plant ignit. protec.
PITOT 1 HTR	Pitot 1 deicing protec.	CABIN BLEED	Cabin air bleed valve protec.
PITOT 2 & STALL HTR	Pitot 2 and stall warning deicing protec.	CABIN TEMP	Cabin temperature valve protec.
INERT SEP	Inertial separator protec.	FAN	Ground fan protec.
LW/S DE ICE	L.H. windshield deicing protec.	MEMORY & CLOCK ACCESS	Stop watch and flowmeter protec. FWD dome light, cabin, baggage compartment bottom, access door lighting & access door closing geared motor protec.
RW/S DE ICE	R.H. windshield deicing protec.	EHSI	EHSI protec.
PROP DE ICE	Propeller deicing protec.	EADI	EADI protec.
AIRFRAME DE ICE	Empennage and wing leading edges deicing protec.	GYRO	Gyros protec.
FLAPS SIG	Flaps signalization protec.	RMI	RMI protec.
LDG GR CONT	Landing gear control protec.	ADI 2	ADI Nr 2 protec.
LDG GR SIG	Landing gear signalization protec.	RMI 2	RMI 2 protec.
AP DISC	Trim and AP cont. protec.	HSI 2	HSI 2 protec.
AP ALERT	Trim and AP audio signalization protec.	ELT	ELT 90 protec.
AP ALT SEL	Altitude selector protec.	PHONES	Reception line protec.
ESS BUS 1	Essential bus 1 circ. protec.	SPKR	Loudspeaker line protec.
ESS BUS 2	Essential bus 2 circ. protec.	COM 1	VHF 1 protec.
ADVISORY 1	Visual warn. protec.	GND CLR	Ground communication protec.
ADVISORY 2	Visual warn. protec.	NAV 1	NAV 1 radio protec.
AUDIO WARN	Audio warnings protec.	COM 2	VHF 2 & NAV 2 radio protec.
L LDG	L.H. landing light protec.	NAV	VHF 2 & NAV 2 radio protec.
TAXI	Taxi light protec.	ENCOD ALTI	Encoding altimeter protec.
R LDG	R.H. landing light protec.	XPDR	Transponder protec.
NAV	Navigation lights protec.	RADIO ALTI	RADIO ALTI protec.
STROBE	Strobe lights protec.	RADIO + FAN	Radio fan protec. + radio master
INSTR	Instruments light. protec.	ADF	ADF protec.
PANEL NORM	Instrument panel normal lighting protec.	DME	DME protec.
PANEL EMER	Instrument panel emergency lighting protec.	MKR	MKR protec.
CABIN	Passenger's reading lamps protec.	STORM	Stormscope protec.
ICE LIGHT	L.H. wing leading edge lighting protec.	WSR	Weather radar protec.
		GC	Radar graphic protec.
		LRN	LORAN long range navigation protec.

Figure 9.9.7A (1 / 2) - EFIS CIRCUIT BREAKERS PANEL



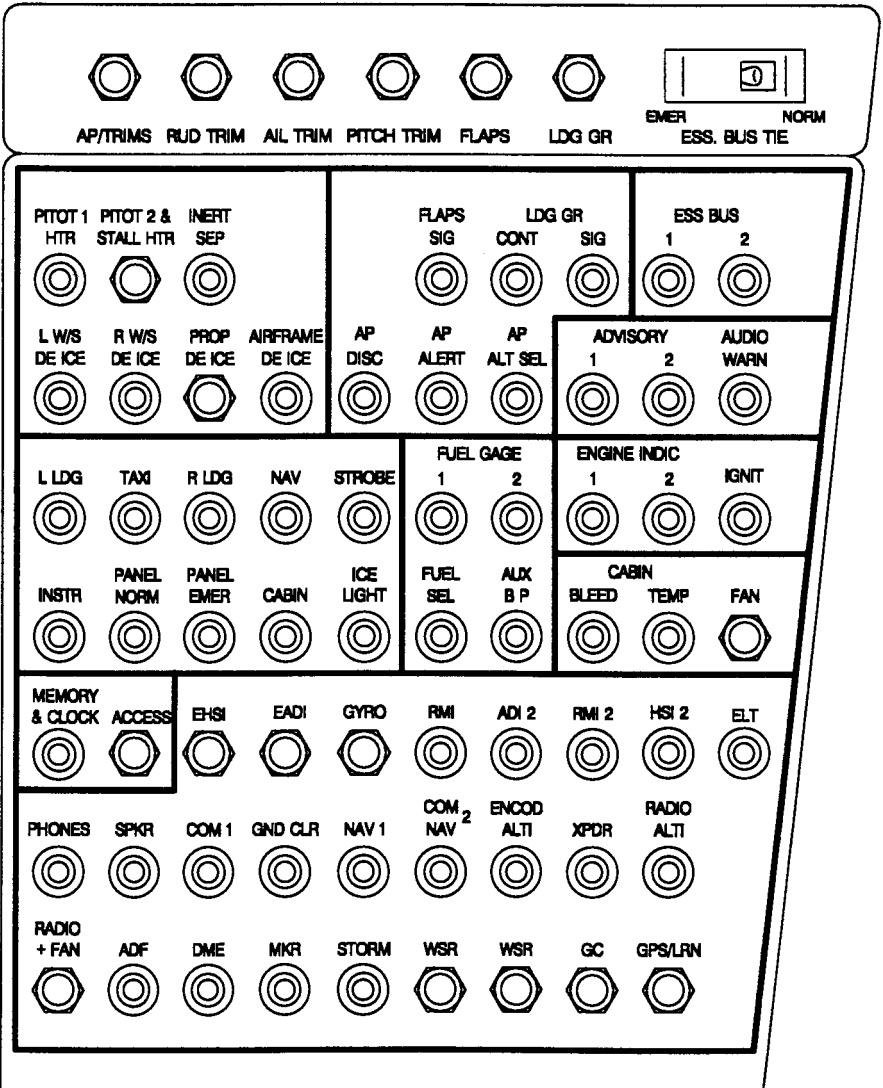

-  Disjoncteur déclenchable
"PULL-OFF" type circuit breaker
-  Disjoncteur non déclenchable
Circuit breaker which cannot be pulled off

Figure 9.9.7A (2 / 2) - EFIS CIRCUIT BREAKERS PANEL

14255004AAAHMAB002

AP / TRIMS	AP & trims general protec.	FUEL GAGE 1	L.H gage protec.
RUD TRIM	Rudder trim protec.	FUEL GAGE 2	R.H gage protec.
AIL TRIM	Aileron trim protec.	FUEL SEL	Timer protec.
PITCH TRIM	Pitch trim protec.	AUX BP	Fuel pump protec.
FLAPS	Flaps protec.	ENGINE INDIC 1	Power plant cont. protec. : Oil temp. & pres., torque, propeller
LDG GR	Landing gear general protec.	ENGINE INDIC 2	Power plant cont. protec. : Ng, flowmeter & ITT
ESS BUS TIE	Essential bus NORM &	IGNIT	Power plant ignit. protec.
PITOT 1 HTR	Pitot 1 deicing protec.	CABIN BLEED	Cabin air bleed valve protec.
PITOT 2 & STALL HTR	Pitot 2 and stall warning deicing protec.	CABIN TEMP	Cabin temperature valve protec.
INERT SEP	Inertial separator protec.	FAN	Ground fan protec.
LW/S DE ICE	L.H. windshield deicing protec.	MEMORY & CLOCK ACCESS	Stop watch and flowmeter protec. FWD dome light, cabin, baggage compartment bottom, access door lighting & access door closing geared motor protec.
RW/S DE ICE	R.H. windshield deicing protec.	ELT	ELT 90 protec.
PROP DE ICE	Propeller deicing protec.	EHSI	EHSI protec.
AIRFRAME DE ICE	Empennage and wing leading edges deicing protec.	EADI	EADI protec.
FLAPS SIG	Flaps signalization protec.	GYRO	Gyros protec.
LDG GR CONT	Landing gear control protec.	RMI	RMI protec.
LDG GR SIG	Landing gear signalization protec.	ADI 2	ADI Nr 2 protec.
AP DISC	Trim and AP cont. protec.	RMI 2	RMI 2 protec.
AP ALERT	Trim and AP audio signalization protec.	HSI 2	HSI 2 protec.
AP ALT SEL	Altitude selector protec.	RADIO ALTI	RADIO ALTI protec.
ESS BUS 1	Essential bus 1 circ. protec.	PHONES	Reception line protec.
ESS BUS 2	Essential bus 2 circ. protec.	SPKR	Loudspeaker line protec.
ADVISORY 1	Visual warn. protec.	COM 1	VHF 1 protec.
ADVISORY 2	Visual warn. protec.	GND CLR	Ground communication protec.
AUDIO WARN	Audio warnings protec.	NAV 1	NAV 1 radio protec.
L LDG	L.H. landing light protec.	COM 2	VHF 2 & NAV 2 radio protec.
TAXI	Taxi light protec.	NAV	NAV 2 radio protec.
R LDG	R.H. landing light protec.	ENCOD	Encoding altimeter protec.
NAV	Navigation lights protec.	ALTI	Transponder protec.
STROBE	Strobe lights protec.	XPDR	LORAN long range navigation protec.
INSTR	Instruments light. protec.	LRN	ADF protec.
PANEL NORM	Instrument panel normal lighting protec.	ADF	DME protec.
PANEL EMER	Instrument panel emergency lighting protec.	DME	MKR protec.
CABIN	Passenger's reading lamps protec.	MKR	Stormscope protec.
ICE LIGHT	L.H. wing leading edge lighting protec.	STORM	Weather radar protec.
		WSR	Radar graphic protec.
		GC	Radio fan protec.
		RADIO + FAN	+ radio master

Figure 9.9.7B (1 / 2) - EFIS CIRCUIT BREAKERS PANEL

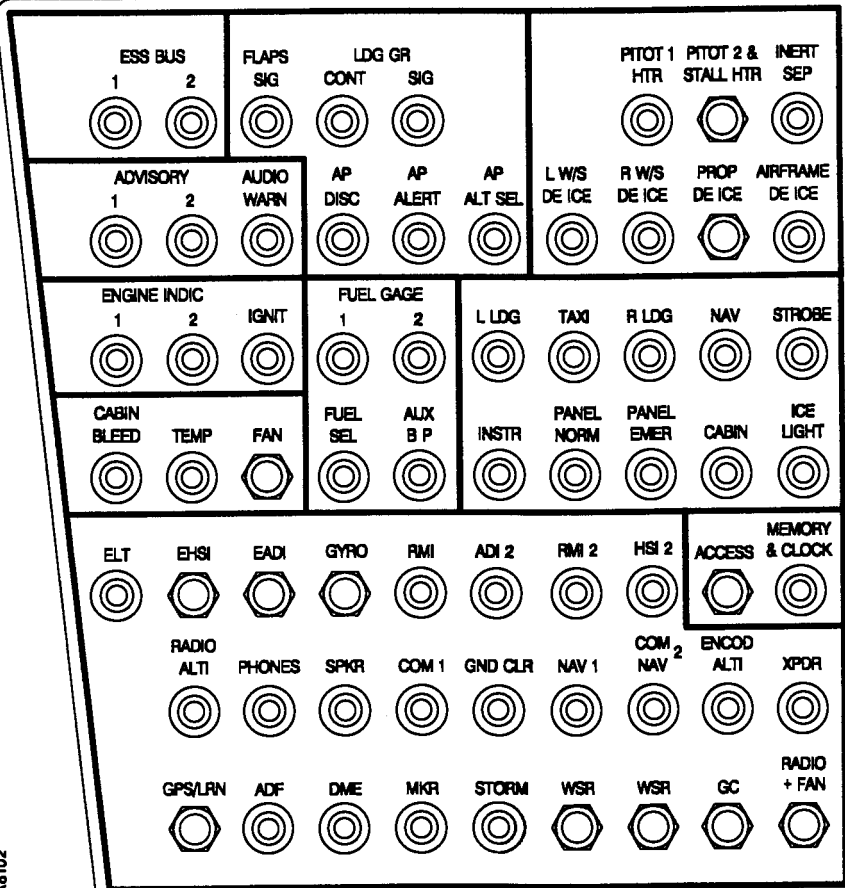
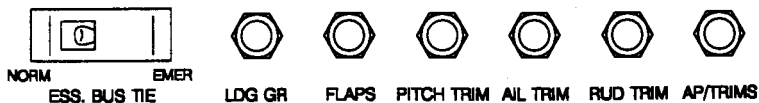

14255004AAAHMA8102



-  Disjoncteur déclenchable
"PULL-OFF" type circuit breaker
-  Disjoncteur non déclenchable
Circuit breaker which cannot be pulled off

Figure 9.9.7B (2 / 2) - EFIS CIRCUIT BREAKERS PANEL

INTENTIONALLY LEFT BLANK

SUPPLEMENT
"BENDIX / KING" AUTOPILOT
TYPE KFC 325

TABLE OF CONTENTS

	Page
1 - GENERAL	9.10.2
2 - LIMITATIONS	9.10.3
3 - EMERGENCY PROCEDURES	9.10.4
4 - NORMAL PROCEDURES	9.10.6
5 - PERFORMANCE	9.10.20
6 - WEIGHT AND BALANCE	9.10.20
7 - DESCRIPTION	9.10.21

SECTION 1 GENERAL

This supplement is provided to acquaint the pilot with the limitations as well as normal and emergency operating procedures of the BENDIX / KING KFC 325 Digital Autopilot. The limitations presented are pertinent to the operation of the KFC 325 System as installed in the TBM 700 airplane. The Autopilot must be operated within the limitations herein specified.

The KFC 325 Autopilot is certified in this airplane with 3 axis control, pitch, roll and yaw damper. The various instruments and the controls for the operation of the KFC 325 System are described in the following pages.

The KFC 325 Autopilot has an electric pitch trim system which provides autotrim during autopilot operation and manual electric trim for the pilot when the autopilot is not engaged. The trim system is designed to withstand any single inflight malfunction.

A lockout device prevents autopilot engagement until the system has been successfully preflight tested.

The following conditions will cause the Autopilot to automatically disconnect :

- A - Power failure.
- B - Internal Flight Control System failure.
- C - Roll rates in excess of 10° / sec. except when the "CWS" push-button is held depressed.
- D - Pitch rates in excess of 5° / sec. except when the "CWS" push-button is held depressed.
- E - Accelerations outside of a 0.3 g to 1.6 g envelope (1.0 g's being normal for straight and level flight).
- F - The presence of "ATTITUDE FAIL" and big "SG" flags.
- G - A movement of the roll trim except when the "CWS" push-button is held depressed.
- H - A movement of the pitch trim.

SECTION 2

LIMITATIONS

These limitations supplement those of standard airplane described in Section 2 "Limitations" of the basic Pilot's Operating Handbook.

- A - During autopilot operation, a pilot with seat belt fastened must be seated at the left pilot position.
- B - The autopilot and yaw damper must be OFF during takeoff and landing.
- C - Do not engage autopilot below 1000 ft (300 m) above ground level in cruise or climb.
- D - Do not use autopilot in approach under 200 ft (60 m).
- E - Autopilot engagement is prohibited with the "PITCH TRIM" circuit-breaker pulled.
- F - IAS for localizer interception is limited to 160 kt.
- G - In "APR" mode - "GS" coupled, flaps must be fully extended in landing position before crossing the OM.

NOTE 1 :

Use of basic pitch attitude hold mode is recommended during operation in severe turbulence.

NOTE 2 :

It is recommended not to use the autopilot with a too high rate of descent below 2000 ft (600 m) above ground level.

SECTION 3
EMERGENCY PROCEDURES

These procedures supplement those of standard airplane described in Section 3 "Emergency procedures" of the basic Pilot's Operating Handbook.

**AUTOPILOT OR ELECTRIC PITCH TRIM
MALFUNCTION**

- 1 - "AP / TRIMS DISC INT" push-button **PRESSED and HELD**
- 2 - "AP / TRIMS MASTER" switch **OFF**
- 3 - "AP / TRIMS DISC INT" push-button **RELEASED**
- 4 - If necessary, control wheel **RETRIM**

CAUTION

WHEN DISCONNECTING THE AUTOPILOT AFTER A PITCH TRIM MALFUNCTION, HOLD THE CONTROL WHEEL FIRMLY ; UP TO 30 POUNDS OF FORCE ON THE CONTROL WHEEL MAY BE NECESSARY TO HOLD THE AIRPLANE LEVEL

NOTE :

Maximum altitude losses due to autopilot malfunction :

<u>Configuration</u>	<u>Altitude loss</u>
<i>Cruise, climb</i>	<i>200 ft</i>
<i>Maneuver, descent</i>	<i>800 ft</i>
<i>Approach</i>	<i>90 ft</i>

**ENGINE FAILURE
(AUTOPILOT COUPLED)**

- 1- "AP / TRIMS DISC INT" push-button **PRESSED**
- 2- In case of engine failure, apply the basic airplane Pilot's Operating Handbook procedures.

SECTION 4 NORMAL PROCEDURES

4.1 - GENERAL

These procedures supplement those of standard airplane described in Section 4 "Normal procedures" of the basic Pilot's Operating Handbook.

4.2 - LIST OF GROUND CHECKS

BEFORE TAXIING	
AUTOPILOT AUTOTEST	
1- Check no flags "ATTITUDE FAIL", "HDG", "SG", "DU"	
2- "TEST" button	PRESS
3- Check :	
- All annunciator lights of control box ON ("TRIM" annunciator flashing).	
- After approximately 5 seconds, all annunciator lights of control box OFF except "AP" which will flash approximately 12 times prior to extinguishing and red "AP" of EADI which will flash approximately 5 times prior to extinguishing and be accompanied by the autopilot audible disconnect tone.	
NOTE : <i>If "TRIM" warning light on the mode controller or if the "PTRM" annunciator on the EADI stays ON, the autotrim did not pass preflight test. The "AP / TRIMS MASTER" switch must be turned to "AP OFF" position. The flight director may be used but the electric pitch trim will be inoperative and the autopilot should not be engaged.</i>	



BEFORE TAXIING (Cont'd)

MANUAL ELECTRIC TRIM TEST

- 1- Actuate left side of split switch unit to the fore and aft positions. The trim wheel should not move on its own. Rotate the trim wheel manually against the engaged clutch to check the pilot's trim overpower capability.
- 2- Actuate right side of split switch unit to the fore and aft positions. Trim wheel should not move on its own and normal trim wheel force is required to move it manually.
- 3- Press the "AP / TRIMS DISC INT" push-button down and hold.
Manual electric trim should not operate either nose up or nose down when both halves of the split switch are actuated to the fore and aft positions.

AUTOMATIC ELECTRIC TRIM TEST

- 1- "AP" button **PRESS**
to engage autopilot
- 2- Control wheel **MOVE**
aft, fore, left and right to verify that
the autopilot can be overpowered
- 3- "AP / TRIMS DISC INT" push-button **PRESS**
Verify that the autopilot disconnects
and all flight director modes are cancelled
- 4- Trim **SET**
to takeoff position

BEFORE TAKEOFF

- 1- "AP / TRIMS DISC INT" push-button **PRESS**

4.3 - LIST OF INFLIGHT CHECKS

AUTOPILOT ENGAGEMENT

"AP" button **PRESS**

Note "AP", "FD" and "YD" annunciators ON. If no other flight director modes are selected at the time of autopilot engagement the mode of operation will be flight director wings level and pitch attitude hold.

CAUTION

DO NOT EXERT ANY PRESSURE ON THE PITCH CONTROL AS THE AUTOPILOT WILL RUN THE PITCH TRIM TO OPPOSE YOUR ACTION

NOTE :

Significant balance changes can occur with speed / power changes or fuel imbalance. With AP engaged it is therefore necessary to check regularly that the plane is trimmed in the roll axis by pressing the "CWS" push-button and if needed retrimming the plane. In case of action on the roll trim, the "CWS" push-button must be kept depressed, otherwise the AP will disconnect.

BASIC MODES**USING CWS**

- 1 - "CWS" push-button **PRESS and MOVE**
airplane nose to the desired attitude
- 2 - "CWS" push-button **RELEASE**

The autopilot will maintain airplane pitch attitude up to the pitch limits of + 15° or - 10°.

USING VERTICAL TRIM

- 1 - Vertical trim control **PRESS**
either "UP" or "DOWN" to modify
airplane attitude at a rate of 0.7 deg / sec.
up to the pitch limits of + 15° or - 10°
- 2 - Vertical trim control **RELEASE**
when desired airplane attitude is reached

The autopilot will maintain the desired pitch attitude.

ALTITUDE MODES

ALTITUDE HOLD

- 1 - "ALT" mode selector button **PRESS**
Note ALT mode annunciator ON

The autopilot will maintain the selected pressure attitude.

ALTITUDE CHANGE

- 1 - Using "CWS" (recommended for altitude changes greater than 100 ft).
- "CWS" push-button **PRESS**
and fly airplane to desired pressure altitude
 - "CWS" push-button **RELEASE**
when desired pressure altitude is reached

The autopilot will maintain the desired pressure altitude.

- 2 - Using Vertical Trim (recommended for altitude changes less than 100 ft).
- Vertical trim control **PRESS**
either "UP" or "DOWN"

Vertical Trim will seek an altitude rate of change of about 500 ft / min.

- Vertical trim control **RELEASE**
when desired pressure altitude is reached

The autopilot will maintain the desired pressure altitude.

SPEED MODES

INDICATED AIRSPEED HOLD

- 1 - "IAS" mode selector button **PRESS**
Note the IAS mode annunciator ON

The autopilot will maintain the current indicated airspeed.

SELECTED INDICATED AIRSPEED CHANGE

- 1 - Using "CWS" (recommended for airspeed changes of 10 KIAS or greater)
- "CWS" push-button **PRESS**
and fly airplane to desired airspeed
 - "CWS" push-button **RELEASE**
when desired airspeed is reached

The autopilot will maintain the desired airspeed.

- 2 - Using Vertical Trim (recommended for airspeed changes less than 10 KIAS).
- Vertical trim control **PRESS**
either "UP" or "DOWN"

Vertical Trim will seek a new airspeed at a rate of about 0.75 knots per second.

- Vertical trim control **RELEASE**
when desired time in seconds has past
i.e. 10 KIAS change desired hold V / T
for approximately 13 seconds

The autopilot will maintain the desired airspeed.

HEADING MODES

HEADING HOLD

- 1 - Heading selector knob **SET**
bug to desired heading
- 2 - "HDG" mode selector button **PRESS**
Note HDG mode annunciator ON

The autopilot will automatically turn the airplane to the selected heading

MANUAL HEADING CHANGE (basic mode)

- 1 - "CWS" push-button **PRESS and TURN**
airplane to the desired heading
- 2 - "CWS" push-button **RELEASE**

The autopilot will maintain airplane in wings level attitude.

NOTE :

Airplane heading may change in the wings level mode due to an airplane out of trim condition.

HEADING CHANGE ("HDG" mode)

- 1 - Heading selector knob **SET**
bug to desired heading

The autopilot will automatically turn the airplane to the new selected heading.

NAVIGATION MODE

- 1- Course bearing pointer **SET**
to desired course
- 2- Establish intercept angle using wings level or "HDG" modes.
- 3- "NAV" mode selector button **PRESS**
 - If the Course Deviation Bar is greater than 2 to 3 dots : the airplane will continue in "HDG" mode (or wings level if "HDG" not selected) with the "NAV-ARM" annunciators illuminated. When the computed capture point is reached, the "HDG" will disengage, the "ARM" annunciator will turn off and the selected course will be automatically captured and tracked.
 - If the D-Bar is less than 2 to 3 dots : the "HDG" mode will disengage upon selecting "NAV" mode ; the "NAV" annunciator will illuminate and the capture / track sequence will automatically begin.

NOTE :

When making relatively small course changes with "NAV" mode engaged, it may be necessary to reinitiate the "NAV" coupling procedures described in the previous paragraph. This will force the autopilot back into a capture mode, allowing the system to establish tracking the new course more rapidly.

CAUTION

IT IS BETTER NOT TO PERFORM AUTOMATIC CAPTURE OF AN "ADF" HEADING.

IT IS RECOMMENDED TO ENGAGE "NAV" MODE WHEN ADF CAPTURE IS PERFORMED.

APPROACH MODE

- 1- Course bearing pointer **SET**
to desired course
- 2- Establish intercept angle using wings level or "HDG"
modes.
- 3- "APR" mode selector button **PRESS**
 - If the Course Deviation Bar is greater than 2 to 3 dots : the airplane will continue in "HDG" mode (or wings level if "HDG" not selected) with the "APR-ARM" annunciators illuminated. When the computed capture point is reached the "HDG" will disengage, the "ARM" annunciators will turn off and the selected course will be automatically captured and tracked.
 - If the D-Bar is less than 2 to 3 dots : the "HDG" mode will disengage upon selecting "APR" mode ; the "APR" annunciator will illuminate steady and the capture / track sequence will automatically begin.

BC APPROACH MODE

- 1 - Course bearing pointer **SET**
to the ILS front course inbound heading
- 2 - Establish intercept angle using wings level or "HDG" mode.
- 3 - "BC" mode selector button **PRESS**
 - If the Course Deviation Bar is greater than 2 to 3 dots : the airplane will continue in "HDG" mode (or wings level if "HDG" not selected) with "APR-ARM", "BC" annunciated. When the computed capture point is reached the "HDG" will disengage, the ARM annunciators will turn off and the selected course will be automatically captured and tracked.
 - If the D-Bar is less than 2 to 3 dots : the "HDG" mode will disengage upon selecting "BC" mode ; the "APR" and "BC" annunciators will illuminate and the capture / track sequence will automatically begin.

CAUTION

WHENEVER THE AIRPLANE IS EQUIPPED WITH "BENDIX / KING" EFS 40, AND THE EHSI FIGURATION IS ON HSI NAV MAP, THE LOCALIZER CDI LEFT-RIGHT DEVIATION IS AUTOMATICALLY CORRECTED BY THE EFS 40 TO ELIMINATE THE NEED TO FLY REVERSE SENSING ON THE BACK COURSE. BC IS ANNUNCIATED AND THE CDI IS CORRECTED FOR PROPER STEERING COMMANDS WHEN THE AIRPLANE HEADING DEVIATES MORE THAN 105° FROM THE COURSE POINTER. THE COURSE POINTER SHOULD BE SET TO THE LOCALIZER FRONT COURSE INBOUND HEADING.

GLIDE SLOPE MODE

NOTE :

"Glide Slope" coupling is inhibited when operating in "NAV" or "APR" + "BC" modes. "Glide Slope" coupling occurs automatically in the "APR" mode.

- 1- "APR" mode **ENGAGED**
- 2- At Glide Slope centering **CHECK "GS" annunciator ON**

NOTE :

The autopilot can capture "Glide Slope" from above or below the beam while operating in either pitch attitude hold, IAS hold, VS hold or ALT hold modes.

NOTE :

If after "Glide Slope" coupling the "Glide Slope" signal becomes inadequate ("GS" flag in view), the "Glide Slope" annunciator will flash at least six times before extinguishing and the system will transfer to pitch attitude hold.

If a valid "Glide Slope" signal returns within six seconds the system will automatically recouple.

If a valid "Glide Slope" signal does not return within six seconds, the airplane must once again pass through the "Glide Slope" beam to achieve "Glide Slope" coupling.

GO-AROUND MODE

- 1- Power lever "GA" push-button **PRESS**
 to disengage the autopilot (if engaged)
 and engage the flight director
 (if not engaged) in a wings level,
 pitch up command.
 Note GA mode annunciator ON
- 2- MISSED APPROACH **EXECUTE**
- 3- Airplane **TRIM**
- 4- Lateral guidance (Select one mode)
 - "HDG" mode **SET bug**
 and PRESS "HDG" push-button
 - "NAV" mode **PRESS**
 "NAV" push-button
 - "APR" mode **PRESS**
 "APR" push-button

Glide Slope coupling will be inhibited so that the LOC can be tracked outbound (the autopilot will not couple to false Glide Slope signals as long as "GA" is engaged).

"GA" is disconnected whenever a vertical mode is engaged.

HALF-BANK ANGLE MODE

"HALF-BANK" mode button **PRESS**

The commanded bank angle will be reduced to $\frac{1}{2}$ the normal value. This mode is functional during "HDG" and "NAV" mode operations but will be automatically deselected and inhibited during "APR" (normal or BC) coupled operations.

SOFT RIDE MODE

"SOFT RIDE" mode button **PRESS**

This mode softens the autopilot's commands to provide a smoother ride during operations in turbulence. The normal autopilot performance (maintaining heading, maintaining wings level, maintaining attitude, maintaining airspeed and / or maintaining altitude) will be degraded by use of the Soft Ride mode.

BEFORE LANDING

"AP / TRIMS DISC INT" push-button **PRESS**
to disengage autopilot
and yaw damper

4.4 - FLIGHT DIRECTOR OPERATION

The flight director modes of operation are the same as those used for autopilot operations except the autopilot is not engaged and the pilot must maneuver the airplane to satisfy the flight director commands.

SECTION 5 PERFORMANCE

The installation and the operation of the autopilot do not change the basic performance of the airplane described in Section 5 "Performance" of the basic Pilot's Operating Handbook.

SECTION 6 WEIGHT AND BALANCE

Weight and balance corresponding to KFC 325 "BENDIX KING" autopilot are given in the optional equipment list attached to Section 6 "Weight and balance" of the basic Pilot's Operating Handbook.

SECTION 7 DESCRIPTION

7.1 - KMC 321 CONTROLLER

This mode controller consists of nine Flight Director mode select push-buttons (Push On - Push Off), mode annunciators, the vertical trim control, the yaw damper engage / disengage push-button, the autopilot engage / disengage push-button and the preflight test push-button.

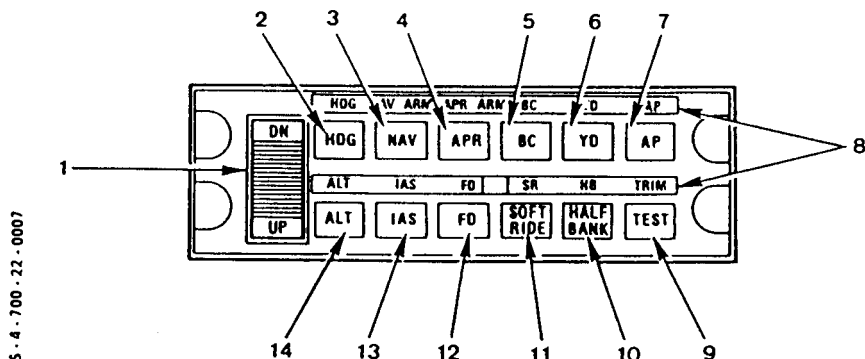

Figure 9.10.1 - KMC 321 AUTOPILOT MODE CONTROLLER

Item 1 - VERTICAL TRIM CONTROL

A spring loaded to center rocker switch which will provide up or down pitch command changes :

- While in Pitch Attitude Hold mode will adjust the pitch attitude at a rate of $0.7^\circ / \text{sec}$.
- While in Altitude Hold mode will adjust the altitude at a rate of $500 \text{ ft} / \text{min}$.
- While in Indicated Airspeed Hold mode will adjust the airspeed at a rate of $0.75 \text{ kt} / \text{sec}$.
- While in the Vertical Speed Hold mode will adjust the vertical speed at a rate of $100 \text{ ft} / \text{min} / \text{sec}$.

- Item 2 - **HEADING (HDG) MODE SELECTOR PUSH-BUTTON**
When pushed, will select the Heading mode which commands the airplane to turn to and maintain the heading selected by the heading bug on the EHSI. A new heading may be selected at any time and will result in the airplane turning to the new heading with a maximum bank angle of about 25°. Selecting "HDG" mode will cancel "NAV", "APR" or "BC" track modes.
- Item 3 - **NAVIGATION (NAV) MODE SELECTOR PUSH-BUTTON**
When pushed, will select the Navigation mode. The mode provides all angle intercepts, automatic beam capture and tracking of "VOR", "RNAV", "ADF" or LOC signals. The "NAV-ARM" annunciators located above this push-button will illuminate until the automatic capture sequence is initiated, then "ARM" will extinguish. The EADI mode annunciator will annunciate the same sequence. A loss of radionavigation signal during more than 7.5 sec. will turn autopilot to wings level attitude basic mode. In that case, "NAV" mode flashes on the EADI mode annunciator.
- Item 4 - **APPROACH (APR) MODE SELECTOR PUSH-BUTTON**
When pushed, will select the Approach mode. This mode provides all angle intercepts, automatic beam capture and tracking of "VOR", "RNAV" or "LOC" signals plus glideslope coupling in the case of an ILS. The tracking gain of the "APR" mode is greater than the gain in the "NAV" mode. The "APR-ARM" annunciators located above this button will illuminate until the automatic capture sequence is initiated, then "ARM" will extinguish. The EADI mode annunciator will annunciate the same sequence.
- Item 5 - **BACK COURSE APPROACH (BC) MODE SELECTOR PUSH-BUTTON**
When pushed will select the Back Course Approach mode. This mode functions identically to the Approach mode except that response to LOC signals is reversed. Glideslope coupling is inhibited in the Back Course Approach mode. The "BC" annunciators (both the KMC 321 and the EADI) will illuminate when this mode is activated plus the Approach Mode annunciators will function as described in Item 4.

- Item 6 - **YAW DAMPER ENGAGE (YD) PUSH-BUTTON**
When pushed, engages the yaw damper independent of the autopilot. When pushed with the yaw damper engaged, disengages the yaw damper.
- Item 7 - **AUTOPILOT ENGAGE (AP ENG) PUSH-BUTTON**
When pushed, engages autopilot and yaw damper if all logic conditions are met. When pushed again, disengages autopilot but does not disengage the yaw damper.
- Item 8 - **MODE ANNUNCIATORS**
The mode symbol located above each mode push-button will illuminate when the mode is engaged except for the "NAV" and "APR" modes. When either the "NAV", "APR" or "BC" mode push-button is pressed, the appropriate "ARM" annunciator above either the "NAV" or "APR" mode push-button will illuminate until the automatic beam capture sequence is initiated. At beam capture "NAV" or "APR" will be annunciated above either the "NAV" or "APR" mode push-button. Normally, the "NAV" or "APR" coupled conditions follow an "ARM" condition but the coupled condition may be entered into directly if the beam capture criteria are met when "NAV", "APR" or "BC" is selected.
- Item 9 - **PREFLIGHT TEST (TEST) PUSH-BUTTON**
When momentarily pushed, initiates preflight test sequence which automatically turns on all annunciator lights, tests the roll and pitch rate monitors, tests the autotrim fault monitor, checks the manual trim drive voltage and tests all autopilot valid and disengage logic. If the preflight test is successfully passed, the "AP" annunciator light will flash for approximately 6 seconds (an audible tone will also sound simultaneously with the annunciator flashes).
The autopilot cannot be engaged until the autopilot preflight tests are successfully passed.
- Item 10 - **HALF BANK (HB) MODE SELECTOR PUSH-BUTTON**
When pushed, engages the Half Bank mode which reduces the certified autopilot commanded maximum bank angle to one half the normal value. This mode is automatically disengaged when the "APR" or "BC" mode is activated.

Item 11 - SOFT RIDE (SR) MODE SELECTOR PUSH-BUTTON

When pushed, engages the Soft Ride mode which reduces the autopilot commands. This command reduces the autopilot aggressiveness which results in a more comfortable ride in turbulent air conditions. This mode is only intended to be used during turbulent air conditions. Routine use of this mode during all flight conditions will result in less than optimum autopilot performance. This mode is automatically disengaged when the "APR" or "BC" mode is activated.

Item 12 - FLIGHT DIRECTOR (FD) MODE SELECTOR PUSH-BUTTON

When pushed, will select the Flight Director mode bringing the Command Bar in view on the EADI and will command wings level and pitch attitude hold.

Item 13 - INDICATED AIRSPEED HOLD (IAS) MODE SELECTOR PUSH-BUTTON

When pushed, engages the Indicated Airspeed Hold mode. The autopilot varies the airplane pitch attitude in order to maintain the selected airspeed during changing air conditions, power changes and / or airplane configuration changes.

Item 14 - ALTITUDE HOLD (ALT) MODE SELECTOR PUSH-BUTTON

When pushed, will select the Altitude Hold mode, which commands the airplane to maintain the pressure altitude existing at the moment of selection.

Engagement may be accomplished in climb, descent, or level flight. In the "APR" mode, altitude hold will automatically disengage when the Glideslope is captured.

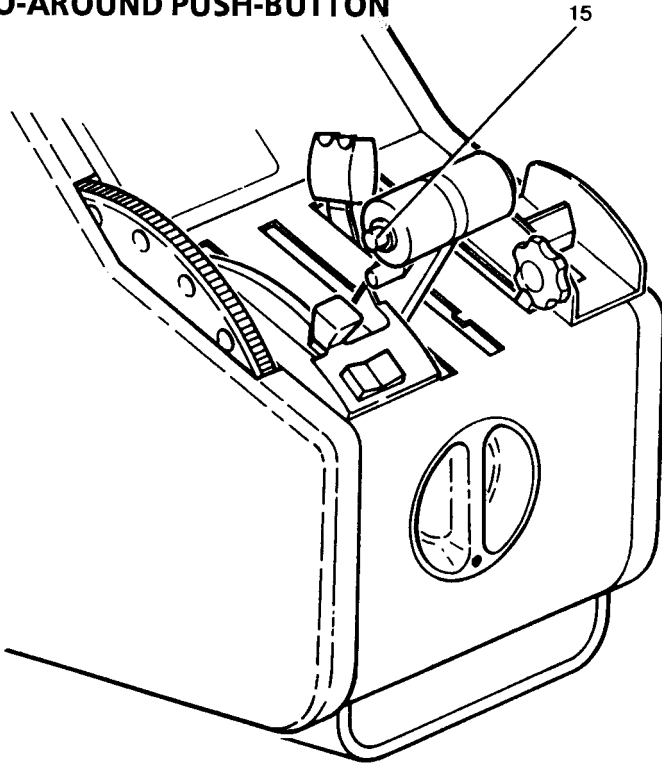
7.2 - GO-AROUND PUSH-BUTTON

S.4.700.22.0014

Figure 9.10.2 - GO-AROUND PUSH-BUTTON**Item 15 - GO AROUND (GA) MODE SELECTOR PUSH-BUTTON**

The button located on the left side of the throttle lever, when pressed, disengages the autopilot and "NAV" or "APR" modes, if engaged. Flight director gives order which allows keeping a fixed pitch up attitude of 8 degrees. GA will annunciate on the EADI mode annunciator. The autopilot and any lateral mode may be re-engaged after the GO AROUND attitude has been manually established. Initiation of any other vertical mode cancels GO AROUND. If GO AROUND is active, Glideslope mode is inhibited.

7.3 - MODE ANNUNCIATOR ON EADI

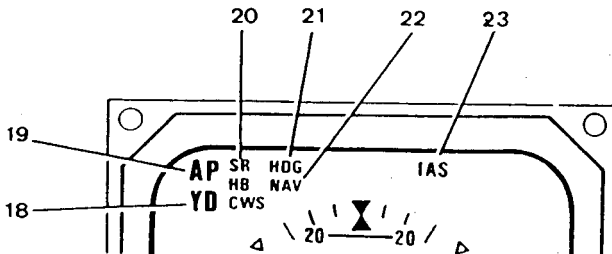
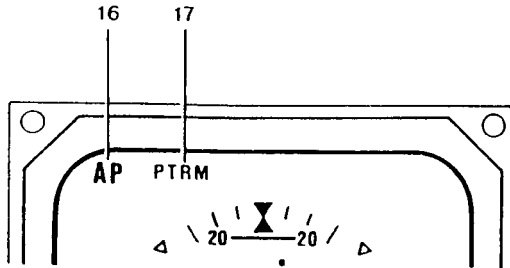

54700220010

Figure 9.10.3 - MODE ANNUNCIATOR ON EADI

- Item 16 - AUTOPILOT (red AP) ANNUNCIATOR
Flashes for a short time whenever the autopilot is disengaged (an audible tone operates too during 2 seconds).

- Item 17 - TRIM WARNING LIGHT (red PTRM)
Illuminates continuously whenever trim power is not on or the system has not been preflight tested. The "PTRM" warning light illuminates and is accompanied by an audible warning whenever a manual trim fault is detected. The Manual Trim System is monitored for the Trim Servo running without a command. The "PTRM" warning light will illuminate and be accompanied by an audible warning tone whenever an autotrim failure occurs. The autotrim system is monitored for the following failures : trim servo running without a command ; trim servo not running when commanded to run ; trim servo running in the wrong direction.
- Item 18 - YAW DAMPER (YD) ANNUNCIATOR
Illuminates continuously whenever the yaw damper is engaged. Flashes for a short time whenever the yaw damper is disengaged.
- Item 19 - AUTOPILOT (green AP) ANNUNCIATOR
Illuminates whenever the autopilot is engaged.
- Item 20 - MODE ANNUNCIATORS
SR (soft ride) : indicates that mode, which softens autopilot commands, is engaged.

HB (half-bank) : indicates that mode, reducing bank angle by a half, is engaged. This mode is automatically disengaged when approach mode is engaged.

CWS : indicates that pilot is pressing "CWS" push-button, which activates the flight director in attitude and wings level hold mode. If autopilot is engaged, it allows to activate control wheel steering.
- Item 21 - ENGAGED LATERAL MODE (green)
Possible modes are "HDG", "NAV", "APR", "LOC" or "BC".
- Item 22 - ARMED LATERAL MODE (white)
Possible modes are "NAV", "APR", "LOC" or "BC".
- Item 23 - ENGAGED LONGITUDINAL MODE (green)
Possible modes are "ALT", "ALTC", "IAS", "VS" or "GS".

7.4 - DIRECTIONAL GYRO SLAVING CONTROL

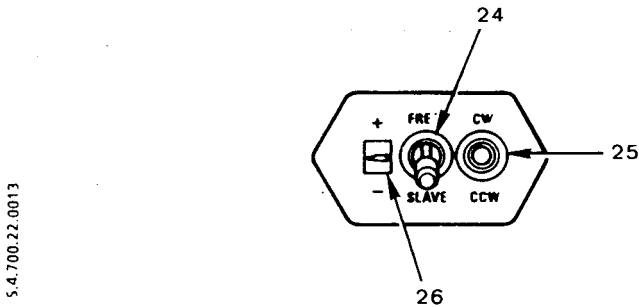

Figure 9.10.4 - KA 51B SLAVING CONTROL AND COMPENSATOR UNIT

- Item 24 - FREE / SLAVE COMPASS SLAVE SWITCH
Selects either the manual (FREE) or automatic slaving (SLAVE) mode for the compass system.
- Item 25 - CW / CCW COMPASS MANUAL SLAVE SWITCH
With the FREE / SLAVE compass slave switch in the FREE position, allows manual compass card to rotate either clockwise or counterclockwise. The switch is spring loaded to the center position.
- Item 26 - SLAVING METER
Indicates the difference between the displayed heading and the magnetic heading. Deflection upwards indicates a clockwise error of the compass card. Deflection downwards indicates a counterclockwise error of the compass card.

7.5 - AUTOPILOT CONTROL WHEEL SWITCH CAP

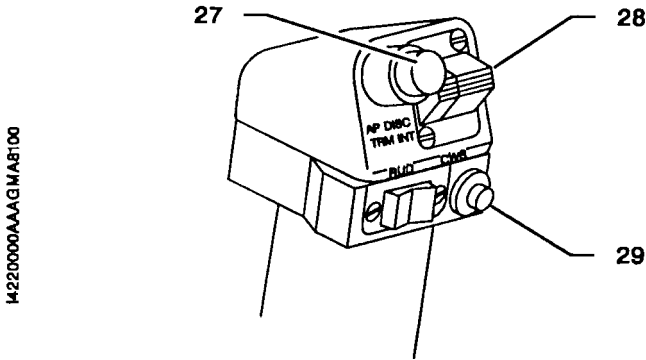

Figure 9.10.5 - AUTOPILOT CONTROL WHEEL SWITCH CAP

Item 27 - AUTOPILOT DISCONNECT / TRIM INTERRUPT (AP / TRIMS DISC INT) PUSH-BUTTON

When shortly depressed, will disengage the autopilot and cancel all operating flight director modes. When depressed and held will interrupt all electric trims power (stop trims motion).

Item 28 - MANUAL ELECTRIC PITCH TRIM CONTROL SWITCHES

A split switch unit in which the left half provides power to engage the trim servo clutch and the right half to control the direction of motion of the trim servo motor. Both halves of the split trim switch must be actuated in order for the manual electric trim to operate in the desired direction. When the autopilot is engaged, operation of the manual electric trim will automatically disconnect the autopilot. (The flight director will remain engaged and the yaw damper will remain engaged if already engaged).

Item 29 - CONTROL WHEEL STEERING (CWS) PUSH-BUTTON

When depressed, allows pilot to manually control the airplane (disengages the pitch, roll and pitch trim servos) without cancellation of any of the selected modes. Will engage the flight director mode if not previously engaged. Automatically synchronizes the flight director / autopilot to the pitch attitude present when the CWS switch is released, to the present pressure altitude when operating in the Altitude hold mode, to the present Vertical Speed when operating in the vertical speed hold mode or to the present Indicated Airspeed when operating in the indicated airspeed hold mode.

7.6 - "AP / TRIMS MASTER" AND "EFIS MASTER" SWITCHES

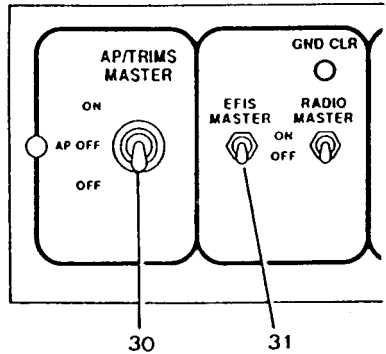
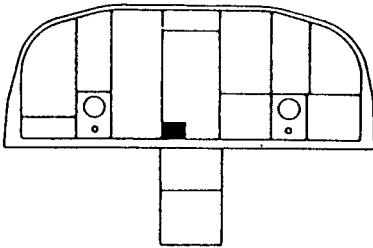

S.4.700.22.0011

Figure 9.10.6 - "AP / TRIMS MASTER" AND "EFIS MASTER" SWITCHES

Item 30 - "AP / TRIMS MASTER" SWITCH

Controls power to all autopilot components and to all electric trims. When set to AP OFF position, autopilot and electric pitch trim are inoperative. When set to OFF position, autopilot and electric trims are inoperative.

Item 31 - "EFIS MASTER" SWITCH

Supplies all components of EFIS system including vertical and directional gyros.

7.7 - CIRCUIT-BREAKERS

Autopilot components are supplied through following circuit-breakers :

<u>LABEL</u>	<u>FUNCTION</u>
AP / TRIMS	Supplies power to KCP 220 autopilot computer, to KS 270A pitch servo, to KS 271A roll servo, to KS 271A yaw servo and to "PITCH TRIM", "AIL TRIM", "RUD TRIM", "AP DISC" and "AP ALT SEL" circuit-breakers.
AP ALERT	Supplies power to the KAA 15 alarm unit.
AP ALT SEL	Supplies power to the KAS 297C vertical speed and altitude selector.
GYRO	Supplies power to the KSG 105 directional compass, to the KVG 350 vertical unit and to the KRG 332 yaw rate gyro.
PITCH TRIM	Supplies power to the KS 272A electric pitch trim.
AP DISC	Delivers a control signal (28 VDC switched by "AP DISC TRM INT" switch) to the KCP 220 autopilot computer and to the KAA 15 alarm unit.
EADI	Supplies power to the SG 465 symbols generator, EADI section
EHSI	Supplies power to the SG 465 symbols generator, EHSI section, to the navigation computer and to the KN 40 navigation converter.

SUPPLEMENT**"BENDIX / KING" KRA 405
RADAR ALTIMETER****TABLE OF CONTENTS**

	Page
1 - GENERAL	9.16.2
2 - LIMITATIONS	9.16.2
3 - EMERGENCY PROCEDURES	9.16.2
4 - NORMAL PROCEDURES	9.16.3
5 - PERFORMANCE	9.16.4
6 - WEIGHT AND BALANCE	9.16.4
7 - DESCRIPTION	9.16.6

SECTION 1**GENERAL**

This supplement provides information necessary for airplane utilization when the "BENDIX / KING" KRA 405 radar altimeter is installed on TBM airplane not equipped with "GARMIN" G1000 system.

The radar altimeter provides the pilot with altitude information within -20 ft and 2500 ft.

SECTION 2**LIMITATIONS**

These limitations complete those of standard airplane described in Section 2 "Limitations" of the basic Pilot's Operating Handbook.

The radio altimeter is not approved as an additional accurate approach aid.

SECTION 3**EMERGENCY PROCEDURES**

The emergency procedures given hereafter complete those of the standard airplane described in Section 3 "Emergency procedures" of the basic Pilot's Operating Handbook.

- During the test, if the radio altimeter does not indicate $50 \text{ ft} \pm 5 \text{ ft}$, the information provided by the radio altimeter must not be used.
- If the DH annunciator (EFIS) or the DH lamp (KNI 415) does not illuminate when the TEST button is depressed, the approach decision height will not be annunciated.
- If the flag comes into view, the information provided by the radar altimeter must not be used.

SECTION 4

NORMAL PROCEDURES

The normal procedures given hereafter complete those of the standard airplane described in Section 4 "Normal procedures" of the basic Pilot's Operating Handbook.

After engine starting :

1. Adjust the DH (Decision Height) to 25 ft.
2. Depress the TEST button. The indicated altitude should be 50 ft \pm 5 ft. The DH annunciator or the DH lamp should be out. When releasing the TEST button, the DH lamp must come on and, if the KNI 415 indicator is installed, the warning tone must sound when the adjusted altitude is reached.
3. With the TEST button depressed, slowly increase the adjusted DH. When the DH annunciator or the DH lamp comes on, the adjusted altitude should be 50 ft \pm 5 ft. The DH annunciator or the DH lamp should also be illuminated at all altitudes above 50 feet.
4. Release the TEST button. The indicated altitude should be 0 ft \pm 5 ft.

Prior to landing :

1. Select the decision height.
2. Depress the TEST button. The indicated altitude should be 50 ft \pm 5 ft and, if the KNI 415 indicator is installed, the warning tone must sound. The DH annunciator or the DH lamp must come on and the warning tone must sound if the adjusted DH is greater than 50 ft.
3. Check that the radar altimeter pointer (KNI 415) or the DH annunciator (EFIS) indicates approximately 2500 ft by using the altimeter as a reference.

SECTION 5 PERFORMANCE

The installation of the "BENDIX / KING" KRA 405 radar altimeter does not change the basic performance of the airplane described in Section 5 "Performance" of the basic Pilot's Operating Handbook.

SECTION 6 WEIGHT AND BALANCE

Weight and balance corresponding to the "BENDIX / KING" KRA 405 radar altimeter are given in the optional equipment list attached to Section 6 "Weight and balance" of the basic Pilot's Operating Handbook.

TBM

700
850

SUPPLEMENT 16

"BENDIX / KING" ***KRA 405***
RADAR ALTIMETER

INTENTIONALLY LEFT BLANK

**SECTION 7
DESCRIPTION****STANDARD VERSION : KNI 415 INDICATOR** (Figure 9.16.1)

The DH lamp can be disabled by depressing it and rearmed by depressing it once again.

- 1) DH lamp
- 2) Flag
- 3) Indicator pointer
- 4) Altitude scale
- 5) DH bug
- 6) DH knob
- 7) Self-test button

Figure 9.16.1 (1 / 2) - KNI 415 INDICATOR

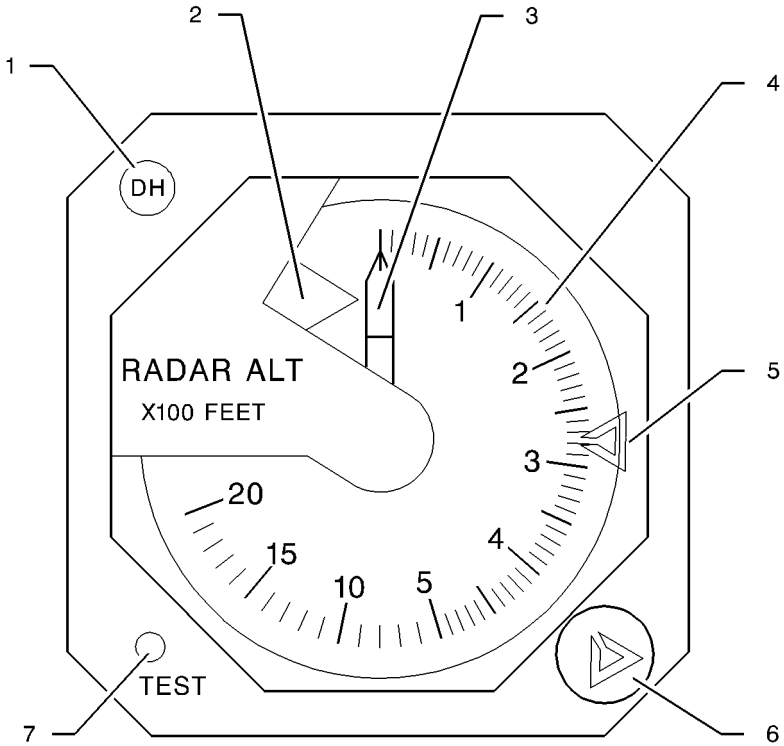

I4341400AAAAA MAB001

Figure 9.16.1 (2 / 2) - KNI 415 INDICATOR

EFIS VERSION (Figure 9.16.2)

- 1) Radar altimeter altitude display
- 2) DH annunciator
- 3) Selected decision height
- 4) DH selection pull-knob
- 5) TEST button

Figure 9.16.2 (1 / 2) - RADAR ALTIMETER : EFIS VERSION
WITHOUT KNI 415 INDICATOR

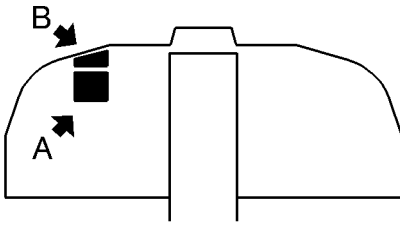

(A)

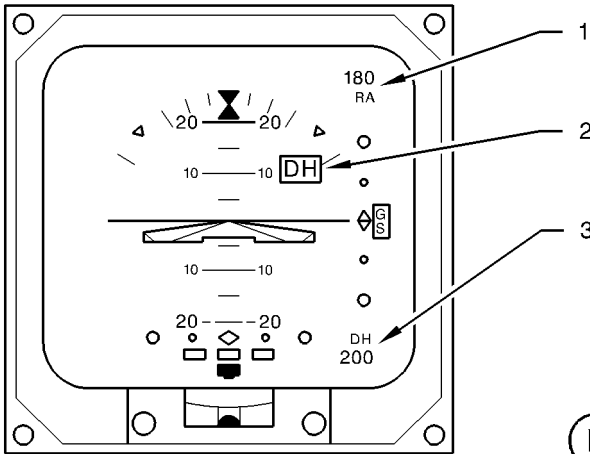

(B)

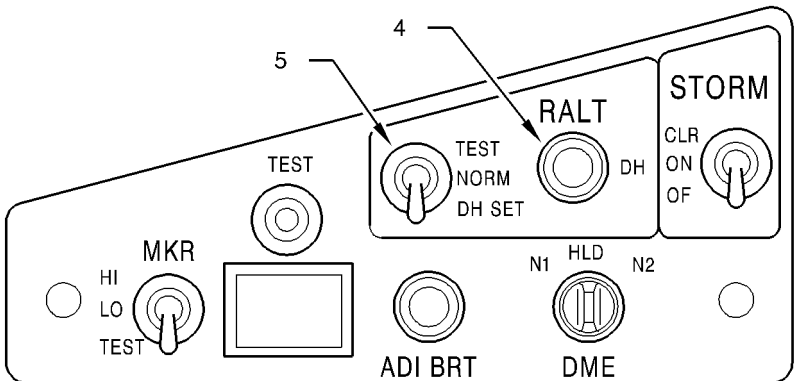

14342800AAADMA8000

Figure 9.16.2 (2 / 2) - RADAR ALTIMETER : EFIS VERSION
WITHOUT KNI 415 INDICATOR

"BENDIX / KING" *KRA 405*
RADAR ALTIMETER

700
850

COMBINED VERSION

The radar altimeter information given in the EADI system are a recopy of the indications and selections made on the KNI 415 indicator.

SUPPLEMENT**"BENDIX/KING" RDR 2000**
VERTICAL PROFILE WEATHER RADAR**TABLE OF CONTENTS**

	Page
1 - GENERAL	9.22.2
2 - LIMITATIONS	9.22.2
3 - EMERGENCY PROCEDURES	9.22.3
4 - NORMAL PROCEDURES	9.22.3
5 - PERFORMANCE	9.22.5
6 - WEIGHT AND BALANCE	9.22.5
7 - DESCRIPTION	9.22.6

SECTION 1

GENERAL

This supplement supplies information necessary for the operation of the airplane when the optional "BENDIX/KING" RDR 2000 vertical profile color weather radar system is installed in the TBM airplane.

SECTION 2

LIMITATIONS

These limitations supplement those of standard airplane described in Section 2 "Limitations" of the basic Pilot's Operating Handbook.

On ground, the radar radiation is inhibited, when the landing gear shock absorbers are compressed. However, it is important to obey the following restrictions :

- Do not operate the radar during refueling operations or in the vicinity of trucks or containers containing flammables or explosives.
- Do not allow personnel within 15 feet of area being scanned by antenna when system is transmitting.

2.1 - RDR 2000 weather radar not interfaced with multi-function display (KMD 850 or GMX 200)

The "BENDIX/KING" RDR 2000 Pilot's Guide P/N 006-08755-0000 at its latest revision shall be readily available to the pilot whenever the operation of the radar system is predicted.

2.2 - RDR 2000 weather radar interfaced with KMD 850 multi-function display

The "BENDIX/KING" RDR 2000 Pilot's Guide P/N 006-08755-0000, the KMD 550/850 Pilot's Guide P/N 006-18222-0000 and the KMD 850 Wx Radar Pilot's Guide Addendum P/N 006-18235-0000 at their latest revision shall be readily available to the pilot whenever the operation of the radar system is predicted.

2.3 - RDR 2000 weather radar interfaced with GMX 200 multi-function display

The "BENDIX/KING" RDR 2000 Pilot's Guide P/N 006-08755-0000 and the "GARMIN" GMX 200 Pilot's Guide P/N 190-00607-02 at their latest revision shall be readily available to the pilot whenever the operation of the radar system is predicted.

SECTION 3

EMERGENCY PROCEDURES

Installation and operation of "BENDIX/KING" RDR 2000 vertical profile weather radar system do not change the basic emergency procedures of the airplane described in Section 3 "Emergency procedures" of the basic Pilot's Operating Handbook.

CAUTION

**IN CASE OF AP COMPUTER FAILURE, THE ANTENNA
STABILIZATION WILL NOT BE OPERATIVE**

SECTION 4

NORMAL PROCEDURES

The normal procedures hereafter supplement those of the standard airplane described in Section 4 "Normal procedures" of the basic Pilot's Operating Handbook.

Normal operating procedures for the vertical profile weather radar system are outlined in the Pilot's Guides, the references of which are given in Section 2 "Limitations" of this Supplement.

AFTER ENGINE STARTING

- | | |
|--|------------|
| - Radar function selection switch | TST |
| Check the antenna scanning and that there is no failure message. | |
| - Radar function selection switch | SBY |

TAKE OFF

- Radar **As required**

If the radar is switched "ON" with the landing gear shock absorbers compressed, the "TX FLT" message appears in the LH. lower corner of the multi-function display (KMD 850 or GMX 200) screen (if installed) or in the RH. lower corner of the radar screen (if multi-function display not installed). The radar radiation is inhibited. The radar automatically radiates, as soon as the aircraft takes off.

BEFORE LANDING

- Radar function selection switch **SBY**

ENGINE SHUT-DOWN

RDR 2000 weather radar interfaced with multi-function display (KMD 850 or GMX 200) :

- "RADIO MASTER" switch **OFF**

RDR 2000 weather radar not interfaced with multi-function display (KMD 850 or GMX 200) :

- Radar function selection switch **OFF**

SECTION 5
PERFORMANCE

Installation of "BENDIX/KING" RDR 2000 vertical profile weather radar system results in a 5 KIAS decrease in maximum cruise performance and a 3 KIAS decrease in Long Range cruise performance described in Section 5 "Performance" of the basic Pilot's Operating Handbook.

SECTION 6
WEIGHT AND BALANCE

Information hereafter supplement the one given for the standard airplane in Section 6 "Weight and balance" of the basic Pilot's Operating Handbook.

A or O	OPTIONAL EQUIPMENT	EQUIPMENT SUPPLIER	WEIGHT per unit lb (kg)	ARM in. (m)
	34 - NAVIGATION			
A	Weather radar RDR 2000 (OPT70 34040A)	KING	21.054 (9.550)	163.70 (4.158)
A	Weather radar RDR 2000 GC 360A coupled (OPT70 34040B)	KING	25.154 (11.410)	161.22 (4.095)
A	Weather radar RDR 2000 EFIS coupled (OPT70 34040E)	KING	21.054 (9.550)	163.70 (4.158)
A	Weather radar RDR 2000 KMD 850 or GMX 200 coupled (OPT70 34040F)	KING	11.530 (5.230)	173.46 (4.406)
A	Weather radar RDR 2000 EFIS and GC 360A coupled (OPT70 34040G)	KING	25.154 (11.410)	161.22 (4.095)
A	Weather radar RDR 2000 EFIS coupled (with CP 466A) (OPT70 34040H)	KING	17.394 (7.890)	167.20 (4.247)

SECTION 7
DESCRIPTION**7.1 - RDR 2000 weather radar not interfaced with multi-function display (KMD 850 or GMX 200)**

All modes and controls, as well as radar clutter display are arranged on a specific screen.

- 1 - Manual gain control knob
- 2 - NAV mode selector button
- 3 - Ground Mapping mode selector button
- 4 - Vertical Profile mode selector button
- 5 - Weather and Weather-Alert toggle selector button
- 6 - Screen brightness control knob
- 7 - Left or right Track mode annunciation
- 8 - Degrees of Track left or right of airplane nose
- 9 - Vertical Profile mode annunciation
- 10 - Relative altitude reference line
- 11 - Plus & minus thousands of feet from relative altitude
- 12 - Radar function selection switch
- 13 - Range selector buttons
- 14 - Left or right Track mode selector buttons
- 15 - Antenna tilt control
- 16 - Range rings
- 17 - Weather or Weather-Alert mode annunciation
- 18 - VP scan angle
- 19 - "TX FLT" annunciation

Figure 9.22.1 (1/2) - Indicator

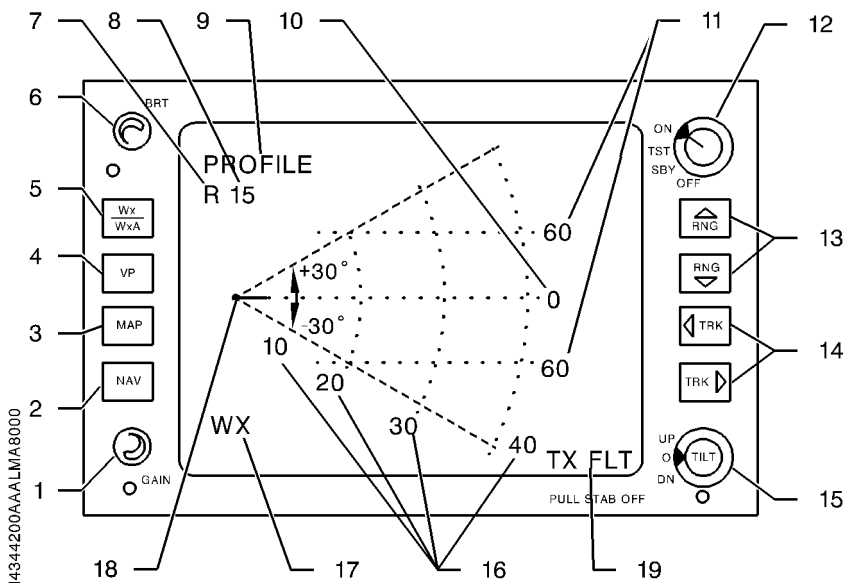
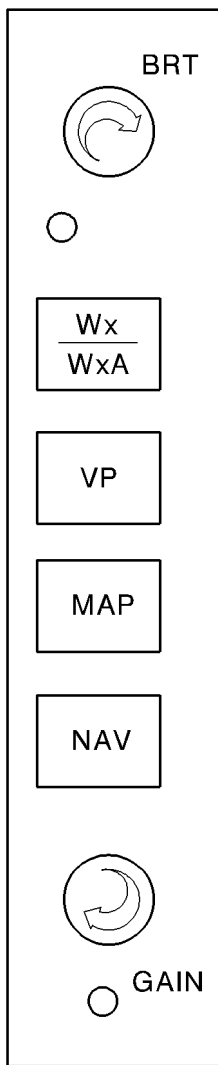

Figure 9.22.1 (2/2) - Indicator

“BENDIX/KING” RDR 2000

WEATHER RADAR

OPERATIONAL CONTROLS



14344200AALLMA8100

BRT Controls brightness of the indicator display.

Wx
WxA Alternately selects between weather (Wx) and "weather-alert" (WxA) modes of operation. "Wx" or "WxA" will appear on the lower left of the display. Areas of high rainfall appear in magenta color. When the WxA mode is selected, magenta areas of storms flash between magenta and black.

VP Selects and deselects the Vertical Profile mode of operation. Selecting the VP mode of operation will not change the selected mode of operation : TST, Wx, WxA or GND MAP. Once in VP, these modes may be changed as desired. VP will engage from the NAV MAP mode, but NAV will be disabled during VP operation.

GND MAP Places indicator in ground-mapping mode disables weather-alert feature and activates gain control. (The magenta is not activated in the GND MAP mode).

NAV MAP Places indicator in navigation mode so that preprogrammed waypoints may be displayed. If other modes are also selected, the NAV display will be superimposed on them. This button is effective only if an optional radar graphics unit and Flight Management System is installed. If actuated without these units, it will cause NO NAV to appear at lower left of screen. The radar is still capable of displaying weather.

GAIN Manual gain control becomes active when GND MAP is selected. In all other modes, gain is internally set.

LOG Used only when the "BENDIX/KING" IU 2023 series radar graphics unit is installed along with a compatible long range navigation system, a listing of the latitudes and longitudes of selected waypoints will be displayed. If a compatible RNAV is installed, selected VOR frequencies, along with bearings and distances to waypoints, will be presented. No radar transmission occurs in this mode.

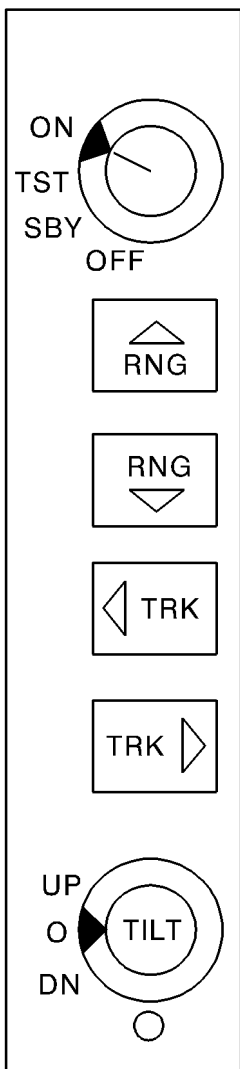

I4344200AAALMA8200

- ON** Radar switch-on/off.
- TST** The test pattern is displayed on the indicator, no transmission occurs.
- SBY** After 30 seconds in this mode, the system is in a state of readiness. No radar transmission occurs, and the antenna is parked in the down position. "STBY" is displayed in the lower left of the display.
- OFF** Removes primary power from the radar indicator and the sensor. The antenna is parked down.
- RNG** When pressed clears the display and advances the indicator to the next range. Upper button increases range, lower button decreases it. Selected range is displayed in lower right corner on the last range mark and distance to other range rings is displayed along the lower edge.
- TRK** When pressed provides a yellow azimuth line and a digital display of the azimuth line placement left or right from the nose of the airplane. For VP operations, the TRK button performs two functions.
 - 1) Prior to engaging VP, the appropriate button (left or right) is used to place the track line at the desired azimuth angle to be vertically scanned (sliced). When VP is engaged, the slice will be taken at the last position of the track line, whether it is visible or not. If the track line has not been selected after power has been applied to system and VP is engaged, the slice will be taken at 0° (directly in front of the airplane).
 - 2) Continuously holding the TRK button will result in the system "slicing" in two-degree increments.
- TILT** Permits manual adjustment of antenna tilt 15° up or down for best indicator presentation. The tilt angle is displayed in the upper right corner of the display. Depending on mode status of the indicator the readout may be in tenths of degree. Pull the Tilt selector knob out for "STAB OFF" operations. "STAB OFF" will appear in the upper left corner of the display. Tilt functions are disabled in VP mode.

“BENDIX/KING” RDR 2000

WEATHER RADAR

7.2 - RDR 2000 weather radar interfaced with KMD 850 multi-function display

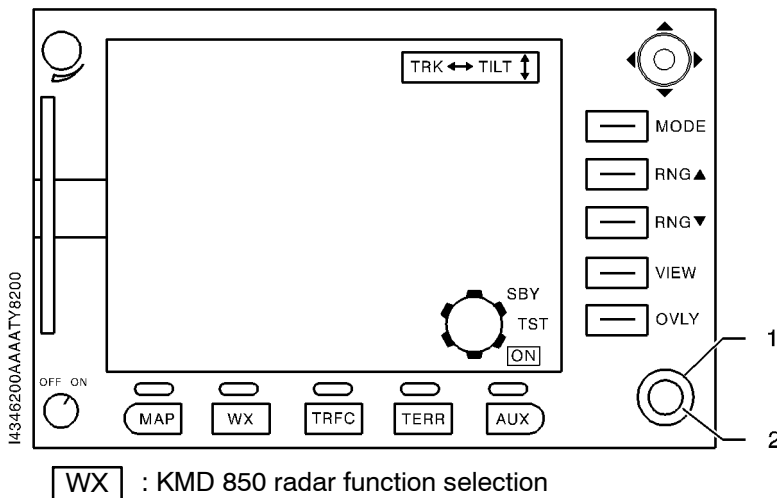

Figure 9.22.2 – KMD 850 Multi-function display

When the KMD 850 is set to radar function, equivalences between KMD 850 and radar standard operational controls described in chapter 7.1 are as follows :

KMD 850 CONTROL	RDR 2000 STANDARD OPERATIONAL CONTROL
MODE	WX/GND MAP
RNG ▼ / RNG ▲	RNG
VIEW	VP
Joystick horizontal movement	TRK
Joystick vertical movement	TILT
1 - Outer knob	SBY / TST / ON
2 - Inner knob	GAIN

7.3 - RDR 2000 weather radar interfaced with GMX 200 multi-function display

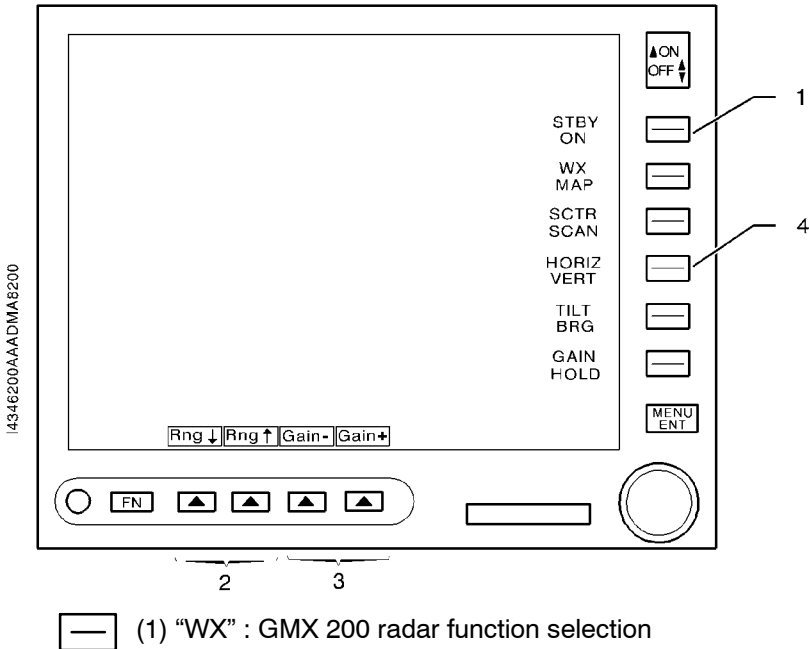

Figure 9.22.3 - GMX 200 Multi-function display

When the GMX 200 is set to radar function, equivalences between GMX 200 and radar standard operational controls described in chapter 7.1 are as follows :

GMX 200 CONTROL	RDR 2000 STANDARD OPERATIONAL CONTROL
1 - (label depends on precedent action)	SBY / ON / OFF
2 - Rng ↑ / Rng ↓	RNG
3 - Tilt ↑ / Tilt ↓	TILT
3 - ← Brg / Brg →	TRK
3 - Gain - / Gain +	GAIN
4 - HORIZ / VERT	VP

■ ***“BENDIX/KING” RDR 2000***
WEATHER RADAR

700
850

■ **Post-MOD70-125-23**

Radar setting to ON or OFF is performed by using the “RADIO MASTER” switch.

SUPPLEMENT
"BENDIX / KING" KLN90B GPS
(B-RNAV) NAVIGATION SYSTEM
INTERFACED WITH EFS 40 EHSI

TABLE OF CONTENTS

	Page
1 - GENERAL	9.26.2
2 - LIMITATIONS	9.26.3
3 - EMERGENCY PROCEDURES	9.26.5
4 - NORMAL PROCEDURES	9.26.7
5 - PERFORMANCE	9.26.12
6 - WEIGHT AND BALANCE	9.26.12
7 - DESCRIPTION	9.26.13

SECTION 1

GENERAL

This supplement is intended to inform the pilot about the equipment limitations, description and operations necessary to the operation when the TBM 700 airplane is equipped with the option ""BENDIX / KING" KLN90B GPS (B-RNAV) NAVIGATION SYSTEM INTERFACED WITH EFS 40 EHSI".

The generalities hereafter supplement those of the standard airplane described in Section 1 "General" of the basic Pilot's Operating Handbook, when the TBM 700 airplane is equipped with the option ""BENDIX / KING" KLN90B GPS (B-RNAV) NAVIGATION SYSTEM INTERFACED WITH EFS 40 EHSI".

Using information provided by satellites ("BENDIX / KING" KLN90B is able to track up to 8 satellites at a time), GPS is an automatic tridimensional (latitude, longitude, altitude) location and navigation means. It also uses data recorded in a data base (two different data bases are available : North American one or International one). The data base is housed in a cartridge plugged into the back of the KLN90B and is updated every 28 days by means of diskettes and a computer (a jack located on right lower panel PL25 provides a means of interfacing the KLN90B with the computer via an interface cable).

Each data base contains information about airports, communication frequencies, VORs, NDBs, Intersections, SIDs, STARs, instrument approaches, flight service stations ...

There is also room for up to 250 user defined waypoints and 26 different flight plans.

CAUTION

IT IS STRONGLY ADVISED NOT TO LOAD USER WAYPOINTS IN DATA BASE IN TERMINAL AREA NAVIGATION DUE TO THE INCREASE OF WORK LOAD FOR THE PILOT

The KLN90B can be interfaced with "SHADIN" fuel flow system. It also receives altitude code from the encoding altimeter.

SECTION 2

LIMITATIONS

The limitations hereafter supplement those of the standard airplane described in Section 2 "Limitations" of the basic Pilot's Operating Handbook, when the TBM 700 airplane is equipped with the option ""BENDIX / KING" KLN90B GPS (B-RNAV) NAVIGATION SYSTEM INTERFACED WITH EFS 40 EHSI".

Data base updating must be verified before each flight.

NOTE :

The original KLN90B data base is in accordance with the WGS84 geodetic model

If the data base or the cartridge are not in accordance with WGS84 or NAD 83 geodetic model, and as there is no means of operation published, GPS navigation system must be disengaged in terminal area.

The navigation sources required for the anticipated flight shall be serviceable. In any case, GPS use is limited to the En route or terminal area of the flight.

The KLN90B fuel management pages use a fuel flow input of the "SHADIN" fuel flowmeter (if installed) and must not be used as a fuel management primary source.

"BENDIX / KING" KLN90B Pilot's Guide at its latest revision shall be readily available to the pilot, each time the GPS navigation system is used.

**GPS
APPROVED FOR B-RNAV
SID/STAR AND APPROACH MODE PROHIBITED**

Figure 9.26.1 - GPS limitation placard

IFR navigation is restricted as follows :

- The system must utilize ORS level 20 or higher.
- IFR en route and terminal area navigation is prohibited unless the pilot verifies the currency of the data base and each selected waypoint for accuracy.
- For every navigation into areas reserved for B-RNAV the pilot must be provided with a predicted availability of RAIM on the route.
- When the GPS is selected as EFIS navigation source, it is prohibited to engage the autopilot Approach mode.
- The use of SIDs and STARs stored in GPS data base and the use of GPS Approach mode are prohibited.

SECTION 3

EMERGENCY PROCEDURES

The emergency procedures hereafter supplement those of the standard airplane described in Section 3 "Emergency procedures" of the basic Pilot's Operating Handbook, when the TBM 700 airplane is equipped with the option ""BENDIX / KING" KLN90B GPS (B-RNAV) NAVIGATION SYSTEM INTERFACED WITH EFS 40 EHSI".

NAV FLAG

If the NAV flag appears on the EHSI when it is interfaced with GPS KLN90B, this means that the GPS signal integrity has been lost.

Return to VOR or ADF navigation source and to remaining operational navigation equipment.

1- "NAV" push-knob of EHSI **PRESS ONCE or TWICE**

"MSG" ANNUNCIATOR ILLUMINATION

1- "MSG" push-knob of KLN90B **PRESS**

Check the message.

If the message mentions the loss of GPS system integrity (RAIM NOT AVAILABLE) or detects a too important position error (RAIM POSITION ERROR) :

Return to VOR or ADF navigation source and to remaining operational navigation equipment.

2- "NAV" push-knob of EHSI **PRESS ONCE or TWICE**

WHEN IN B-RNAV VERIFY THE IFR PROCEDURE APPLICABLE TO EACH ONE OF THESE NEW SITUATIONS WITH THE AIR TRAFFIC CONTROL :

- **OUT OF B-RNAV AREA : IT IS PROHIBITED TO ENTER THE B-RNAV AREA.**
- **IN B-RNAV AREA : INFORM THE AIR TRAFFIC CONTROL TO INDICATE THE LOSS OF B-RNAV CAPABILITY.**

When the system integrity is restored, the return to GPS mode must be accompanied by the validation of the followed and desired track concordance by using primary sources of navigation.

SECTION 4

NORMAL PROCEDURES

The normal procedures hereafter supplement those of the standard airplane described in Section 4 "Normal procedures" of the basic Pilot's Operating Handbook, when the TBM 700 airplane is equipped with the option " "BENDIX / KING" KLN90B GPS (B-RNAV) NAVIGATION SYSTEM INTERFACED WITH EFS 40 EHSI".

Normal operating procedures of the KLN90B GPS recommended by "BENDIX / KING" manufacturer are outlined in the "BENDIX / KING" KLN90B Pilot's Guide at the latest revision and KLN90B Memory Jogger at the latest revision.

However, it is important to precise the following points for the use of KLN90B on TBM700 :

SET UP CONDITIONS

- In case of B-RNAV use :

During the preflight planning phase, the availability of GPS integrity (RAIM) shall be confirmed for the intended flight (route and time). This will be obtained from a prediction program (e.g. : "BENDIX KING" PREFLIGHT PLUS).

B-RNAV flight dispatch shall not be made in the event of a continuous loss of RAIM for more than 5 minutes predicted in any part of the intended flight.

With 23 or more satellites available, the predicted availability of RAIM is valid for 7 days.

When less than 23 satellites are available, the predicted availability of RAIM shall be confirmed short before each flight.

- The system must utilize ORS level 20 or higher in compliance with the Pilot's Guide.

- Verify if the data base is current. Verify data on the self test page.
- Verify that altitude data is valid to the KLN90B prior to flight.
- Set turn anticipation mode (SET / 6) to :
 - . ENABLE (turn anticipation ENABLED) : recommended mode,
 - . DISABLE (turn anticipation DISABLED) : not recommended mode.
- Check that the proper criteria are used for nearest airport selection (SET / 3).

The course deviation indicator sensitivity is adjustable with a maximum value which is the default value selected by the KLN90B. It is recommended not to change the default value which is ± 5 NM full scale.

In order to reduce navigation errors in terminal area, the course deviation indicator scale shall be set to ± 1 NM or navigation shall be conducted with autopilot.

SYSTEM ANNUNCIATORS / SWITCHES / CONTROLS

EHSI presentation "NAV" push-knob

It may be used to select data for presentation on the pilot's EHSI ; either NAV data from NAV 1 or NAV 2 navigation receiver or GPS data from the KLN90B GPS or ADF data

"NAV" symbol is green, "GPS" symbol is blue, "ADF" symbol is green.

"MSG" message annunciator

CAUTION

"MSG" ANNUNCIATOR MAY BE PERMANENTLY ILLUMINATED IF THERE EXISTS A PERMANENT MESSAGE. WHEN A NEW MESSAGE APPEARS, "MSG" ANNUNCIATOR ONLY FLASHES.

It will flash to alert the pilot of a situation that requires his attention. Press the "MSG" button on the KLN 90B GPS to view the message. (Appendix B of the KLN90B Pilot's Guide contains a list of all the messages likely to appear on the "Message" page and their meanings). "MSG" annunciator is amber.

"WPT" Waypoint annunciator

Prior to reaching a waypoint in the active flight plan, the KLN90B GPS will provide navigation along a curved path segment to ensure a smooth transition between two adjacent legs in the flight plan. This feature is called turn anticipation. Approximately 20 seconds prior to the beginning of the turn anticipation, the "WPT" annunciator will flash, going solid upon initiation of the turn, and extinguishing upon turn completion.

"WPT" annunciator is amber. "WPT" symbol is also displayed white on L.H. side of the EHSI.

GPS approach "GPS APR, ARM, ACTV" switch / annunciator

This switch / annunciator is used to select or deselect approach mode of the KLN90B. This operation mode is prohibited.

GPS course "GPS CRS, OBS, LEG" switch / annunciator

This switch / annunciator is used to select the basic operation modes of the KLN90B, either a single waypoint with omnibearing selector (OBS) selection through the waypoint (like a VOR) or automatic leg sequencing (LEG) between waypoints.

"GPS CRS" annunciator is white. "OBS" annunciator is amber. "LEG" annunciator is green.

NOTE :

Either LEG or OBS will illuminate during system self-test depending on switch position.

EN ROUTE-LEG mode

When using the en route-leg mode, GPS navigation data are differently presented on the EHSI according to the selected mode :

- display equivalent to an electromechanical HSI (track, course deviation, TO / FROM) in ARC or HSI modes,
- trace of the navigation in "MAP" mode. The active leg is blue, the following legs are white.

When crossing a waypoint, the track resetting on following navigation leg automatically occurs.

When turn anticipation is ENABLED, the "WPT" annunciator will flash about 20 seconds before the initialization of the turn, going solid upon the turn, and extinguishing upon turn completion.

When turn anticipation is DISABLED, the "WPT" annunciator will flash, until waypoint vertical line is crossed, then extinguishes.

The navigation course selecting knob "CRS" is inactive.

With the autopilot engaged on NAV mode, the EHSI automatic resetting, when crossing a waypoint, allows to the aircraft an automatic transition from leg to leg without pilot action.

EN ROUTE-OBS mode

When using the "ENROUTE-OBS" mode, the desired radial selection on the waypoint is made equally from the course selecting knob "CRS" of the EHSI or from the KLN90B control box. The recopy is quasi instantaneous.

FLIGHT DIRECTOR / AUTOPILOT COUPLED OPERATION

The EHSI may be coupled with KFC 325 autopilot.

Engaging the "NAV" mode on the autopilot mode controller will make the FD appear on the EADI, which uses selected course and left / right steering information presented on the EHSI.

This information is related to the navigation source (VOR, GPS or ADF) selected by the push-button "NAV" on the EHSI.

When AP is engaged on the mode controller, the autopilot is then coupled to the EHSI and uses displayed information (track and course deviation).

In order to reduce navigation errors in terminal area, the course deviation indicator scale shall be set to ± 1 NM or navigation shall be conducted with autopilot.

NOTE :

When the EHSI is selected on GPS navigation source, the RMI remains selected on NAV 1 source (VOR or RNAV).

**SECTION 5
 PERFORMANCE**

Installation and operation of the "BENDIX / KING" KLN90B GPS (B-RNAV) NAVIGATION SYSTEM INTERFACED WITH EFS 40 EHSI" do not change the performance of the airplane described in Section 5 "Performance" of the basic Pilot's Operating Handbook.

**SECTION 6
 WEIGHT AND BALANCE**

Information hereafter supplement the one given for the standard airplane in Section 6 "Weight and balance" of the basic Pilot's Operating Handbook.

R S A or O	REQUIRED (R) OR STANDARD (S) OR OPTIONAL (A or O) EQUIPMENT	EQUIPMENT SUPPLIER	WEIGHT per unit lb (kg)	ARM in. (m)
A	34 - NAVIGATION Attitude and direction GPS, EFIS coupled KLN90B (B-RNAV) (OPT70 34033D)	KING	8.774 (3.980)	155.20 (3.942)

SECTION 7

DESCRIPTION

Normal operating procedures of the "BENDIX / KING" KLN90B GPS (B-RNAV) navigation system interfaced with EFS 40 EHSI are described in the "BENDIX / KING" KLN90B Pilot's Guide at the latest revision.

CONTROLS - see Figure 9.26.2

Controlled by two sets of concentric knobs and two cursor buttons, the KLN90B can present a variety of information in a number of different page formats.

The various display types can be considered as chapters in a book, each chapter having 26 pages. With a few exceptions, each of these pages can be changed independently.

Generally the 2 concentric knobs and the cursor button to the left of the screen are used to select data on L.H. page, the knobs and cursor on the right control the R.H. page.

The large outer knobs control the chapters and the small inner knobs turn the pages.

To change data in a page use the cursor function. This function is an area of inverse video on the screen brought up by depressing the cursor button.

Then rotate the outer knob to position the cursor and the inner knob to select the desired characters. Repeat this operation as many times as necessary and valid (ENT button).

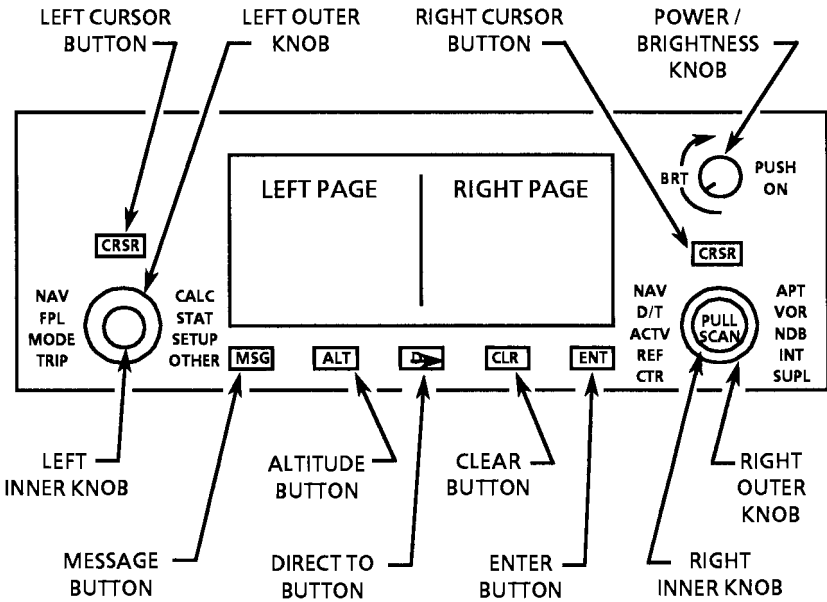
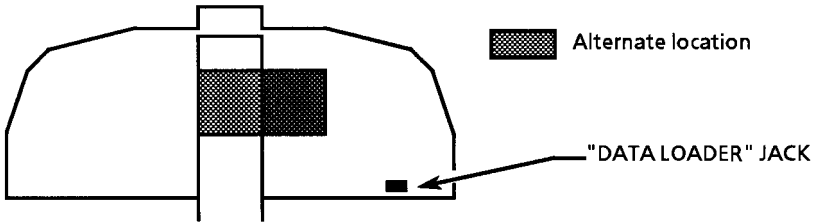
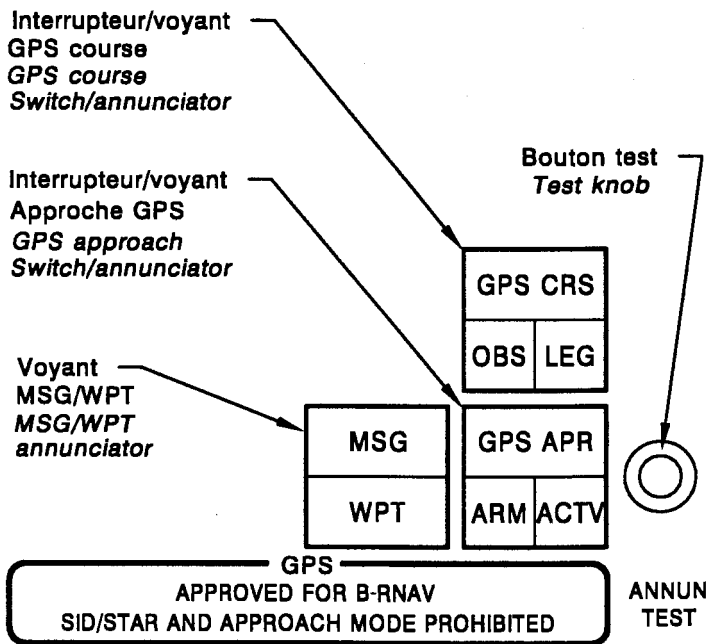
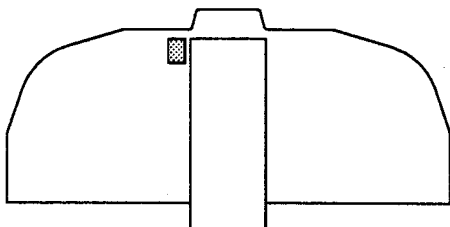

Figure 9.26.2 - Controls



14113006AAASMA8001

Figure 9.26.3 - GPS placard and annunciators

INTENTIONALLY LEFT BLANK

SUPPLEMENT**"BFG" SKYWATCH**
SKY 497 OR SKY 899
TRAFFIC ADVISORY SYSTEM**TABLE OF CONTENTS**

	Page
1 - GENERAL	9.28.3
2 - LIMITATIONS	9.28.3
3 - EMERGENCY PROCEDURES	9.28.3
4 - NORMAL PROCEDURES	9.28.4
5 - PERFORMANCE	9.28.4
6 - WEIGHT AND BALANCE	9.28.5
7 - DESCRIPTION	9.28.6

"BFG" SKYWATCH
TRAFFIC ADVISORY SYSTEM

INTENTIONALLY LEFT BLANK

SECTION 1**GENERAL**

This supplement is intended to inform the pilot about the equipment limitations, description and operations necessary to the operation when the TBM 700 airplane is equipped with the option "BFG" SKYWATCH SKY 497 OR SKY 899 TRAFFIC ADVISORY SYSTEM.

The SKYWATCH traffic advisory system relies on information obtained from nearby aircraft transponders. It does neither detect, nor track aircraft which are not equipped with an operating ATCRBS transponder.

SECTION 2**LIMITATIONS**

The installation of the "BFG" SKYWATCH traffic advisory system does not change the basic limitations of the airplane described in Section 2 "Limitations" of the basic Pilot's Operating Handbook.

REMARK :

The SKYWATCH is a TAS (advisory means), not a TCAS.

SECTION 3**EMERGENCY PROCEDURES**

The installation of the "BFG" SKYWATCH traffic advisory system does not change the emergency procedures of the airplane described in Section 3 "Emergency procedures" of the basic Pilot's Operating Handbook.

"BFG" SKYWATCH
TRAFFIC ADVISORY SYSTEM**SECTION 4**
NORMAL PROCEDURES

Normal operating procedures of the "BFG" SKYWATCH traffic advisory system are outlined in :

- the Pilot's Guide for the "BFG" SKYWATCH™ traffic advisory system, Model SKY 497 P/N 009-10801-001 Rev. B dated 06/00 or any applicable following edition
or
- the Pilot's Guide for the "BFG" SKYWATCH® HP traffic alert/advisory system, Model SKY 899 P/N 009-11901-001 Rev. A dated 08/01 or any applicable following edition and :
 - . the Multi-function Display Traffic Avoidance Function (TCAS/TAS) Pilot's Guide Addendum P/N 006-18238-0000 Rev. 0 dated 04/01 or any applicable following edition, if data are displayed on a KMD 850 MFD,
 - . the "GARMIN" GNS 530 Pilot's Guide, P/N 190-00181-00 Revision A dated 04/00 or any applicable following edition, if data are displayed on a GNS 530 GPS.

WARNING

DO NOT ATTEMPT EVASIVE MANEUVERS BASED SOLELY ON TRAFFIC INFORMATION SHOWN ON THE SKYWATCH DISPLAY. INFORMATION ON THE DISPLAY IS PROVIDED TO THE FLIGHT CREW AS AN AID IN VISUALLY ACQUIRING TRAFFIC; IT IS NOT A REPLACEMENT FOR ATC AND SEE & AVOID TECHNIQUES

When the SKYWATCH traffic advisory system issues a Traffic Alert (aural or visual), look outside for the intruder aircraft. When you spot an intruder aircraft, use normal right-of-way procedures to maintain separation.

SECTION 5
PERFORMANCE

The installation of the "BFG" SKYWATCH traffic advisory system does not change the basic performance of the airplane described in Section 5 "Performance" of the basic Pilot's Operating Handbook.

SECTION 6
WEIGHT AND BALANCE

Information hereafter supplement the one given for the standard airplane in Section 6 "Weight and balance" of the basic Pilot's Operating Handbook.

A or O	OPTIONAL EQUIPMENT	EQUIPMENT SUPPLIER	WEIGHT per unit lb (kg)	ARM in. (m)
34 - NAVIGATION				
A	Traffic advisory system SKYWATCH™ SKY 497 (OPT70 34047A)	BFG	15.780 (7.16)	145.91 (3.706)
A	Traffic advisory system (EFIS version) SKYWATCH™ SKY 497 (OPT70 34047B)	BFG	13.140 (5.96)	150.12 (3.813)
A	Traffic advisory system SKYWATCH® HP SKY 899 (OPT70 34059)	BFG	12.720 (5.77)	151.18 (3.840)

"BFG" SKYWATCH
 TRAFFIC ADVISORY SYSTEM

SECTION 7
DESCRIPTION

The SKYWATCH is an airborne Traffic Advisory System (TAS). It monitors the airspace around your aircraft and advises the flight crew where to look for transponder equipped aircraft that may pose a collision threat.

SKYWATCH SKY 497

The traffic can be displayed on the stormscope display, whether a stormscope system is installed or not.

The display range is 2 NM or 6 NM.

SKYWATCH SKY 899

The traffic can be shown on a dedicated screen (KMD 850 MFD or GNS 530 GPS) and/or on the EFS 40.

The controls ("TEST" or "TEST/MODE", "ON", "OFF" and "ST-BY/OPR") are remote from the screen (see Figures 9.28.1 and 9.28.2).

The display range is between 2 NM and 20 NM.

All

The traffic detected is displayed, when the vertical separation between your own aircraft altitude and the intruder altitude ranges :

MODE	From	Up to
ABV (Look up)	- 2700 ft	+ 9000 ft
NRM (Normal)	- 2700 ft	+ 2700 ft
BLW (Below)	- 9000 ft	+ 2700 ft

The Traffic Advisory (TA) criteria, which initiates a visual and/or an aural alert, are (sensitivity level B) :

- detection of an intruder aircraft within a 0.55 NM horizontal radius and a \pm 800 ft relative altitude,
- approach of an intruder aircraft on a course that will intercept your course within 20 to 30 seconds.

Post-MOD70-125-23

SKYWATCH setting to ON or OFF is performed by using the "RADIO MASTER" switch.

AIRCRAFT EQUIPPED WITH THE KRA 405B RADIO ALTIMETER

When the aircraft is at a ground height lower than 2000 ft, the Traffic Advisory (TA) criteria, which initiate a visual and/or an aural alert, are (sensitivity level A) :

- detection of an intruder aircraft within a 0.2 NM horizontal radius and a \pm 600 ft relative altitude,
- approach of an intruder aircraft on a course that will intercept your course within 15 to 20 seconds.

When the aircraft is at a ground height lower than 1700 ft, the traffics which ground height is lower than 380 ft will no longer be displayed.

The aural traffic alert is inhibited when the height detected by the radio altimeter is below 400 ft.

"BFG" SKYWATCH
TRAFFIC ADVISORY SYSTEM

I4344400AAAAAIA8000

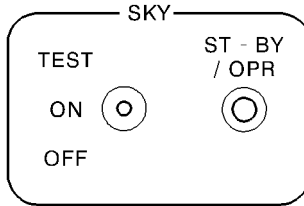

- TEST : Held position for test
- ST-BY/OPR : 1st press : Skywatch stand-by
2nd press : OPR selection

Figure 9.28.1 - SKYWATCH SKY 899 remote control :
EFS 40 display impossible

I4344400AAAAAIA8200

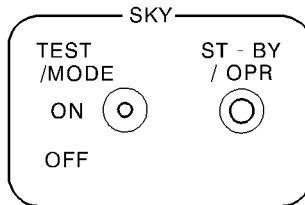

- ST-BY/OPR : Skywatch stand-by
- TEST/MODE : 1st case : When the SKY 899 is in stand-by, tests the Skywatch
2nd case : When the SKY 899 is in OPR, changes display type (NORM, BLW, ABV) in the EFS 40

NOTE :
EFS 40 TEST/REF knob enables selection of SKY 899 Skywatch data display in the EFS 40.

Figure 9.28.2 - SKYWATCH SKY 899 remote control
with display on EFS 40

SUPPLEMENT

CARGO TRANSPORTATION CAPABILITY

TABLE OF CONTENTS

	Page
1 - GENERAL	9.30.3
2 - LIMITATIONS	9.30.3
3 - EMERGENCY PROCEDURES	9.30.6
4 - NORMAL PROCEDURES	9.30.6
5 - PERFORMANCE	9.30.6
6 - WEIGHT AND BALANCE	9.30.7
7 - DESCRIPTION	9.30.16
8 - HANDLING, SERVICING AND MAINTENANCE	9.30.21

INTENTIONALLY LEFT BLANK

SECTION 1**GENERAL**

This supplement is intended to inform the pilot about the limitations, description and operations necessary to load the airplane in order to perform cargo transportation.

- For this utilization, the freight is installed in the cabin aft of the front seats.

SECTION 2**LIMITATIONS**

The limitations hereafter supplement those of the standard airplane described in Section 2 "Limitations" of the basic Pilot's Operating Handbook, when the airplane is equipped with the option "CARGO TRANSPORTATION CAPABILITY".

OCCUPANTS

- Front L.H. seat .. 1 (pilot)
- Front R.H. seat .. 0 [with partition net, P/N T700B259001100000
(emergency exit not accessible)]
..... 1 [with partition net, P/N T700B259001800000
(emergency exit accessible)]

Front R.H. seat occupied

The specific partition net, P/N T700B259001800000 must be installed. This net allows bulk freight only.

A clear path must be available to the emergency exit. In particular, no cargo or equipment may be stowed on top of the net forward of frame 10.

FREIGHT WEIGHT LIMITATIONS

Bulk freight [max. density 6.24 lb/cu.ft (100 kg/m³)]:

- between the two partition nets 441 lbs (200 kg)
- aft of the rear partition net 220 lbs (100 kg)

Container, pallet or heavy box freight :

- front container, pallet or heavy box 396.8 lbs (180 kg)
- rear container, pallet or heavy box 330.7 lbs (150 kg)

Max. floor load 38.5 lb/sq.ft (188 kg/m²)

Max. dimensions of containers, pallets or heavy boxes :

- Length 47.24 in (1.20 m)
- Width 31.50 in (0.80 m)
- Height (front container, pallet or heavy box) 39.37 in (1.00 m)
- Height (rear container, pallet or heavy box) 31.50 in (0.80 m)

PLACARDS

- (1) On the raiser at frame 13bis, inside the cabin

I4255004AAJMA18002

LOADING LIMITS	
<p style="text-align: center;"><u>CONTAINERS, PALLETS AND HEAVY BOXES</u></p> <p style="text-align: center;">330 Kg (727 lbs) MAXIMUM</p> <p style="text-align: center;">188 Kg / m² (38,5 lb/sq.ft) MAXIMUM</p>	<p style="text-align: center;"><u>BULK</u></p> <p style="text-align: center;">200 Kg (441 lbs) BETWEEN PARTITION NETS</p> <p style="text-align: center;">100 Kg (220 lbs) AFT OF REAR PARTITION NET</p> <p style="text-align: center;">100 Kg / m³ (6,24 lb/cu.ft)</p>
<p>FOR LOADING INSTRUCTIONS REFER TO RELEVANT SUPPLEMENT IN PILOT'S OPERATING HANDBOOK</p>	
<p>IT IS THE PILOT'S RESPONSIBILITY TO CHECK THAT ALL THE CARGO IS PROPERLY SECURED</p>	

- (2) Under L.H. front side window

I4113200AAABMA8000

CARGO OPERATION LIMIT

DO NOT USE FRONT RIGHT SEAT
IF EMERGENCY EXIT IS NOT ACCESSIBLE

SECTION 3
EMERGENCY PROCEDURES

The installation of the option "CARGO TRANSPORTATION CAPABILITY" does not change the basic emergency procedures of the airplane described in Section 3 "Emergency procedures" of the basic Pilot's Operating Handbook.

SECTION 4
NORMAL PROCEDURES

The normal procedures hereafter supplement those of the standard airplane described in Section 4 "Normal procedures" of the basic Pilot's Operating Handbook, when the airplane is equipped with the option "CARGO TRANSPORTATION CAPABILITY".

PREFLIGHT INSPECTION

Bulk freight

Partition nets in place **CHECK**

Container, pallet or heavy box freight

Stowing nets in place **CHECK**

SECTION 5
PERFORMANCE

The installation of the option "CARGO TRANSPORTATION CAPABILITY" does not change the basic performance of the airplane described in Section 5 "Performance" of the basic Pilot's Operating Handbook.

SECTION 6
WEIGHT AND BALANCE

Information hereafter supplement the information given for the standard airplane in Section 6 "Weight and Balance" of the basic Pilot's Operating Handbook, when the airplane is equipped with the option "CARGO TRANSPORTATION CAPABILITY".

S A or O	STANDARD OR OPTIONAL EQUIPMENT	EQUIPMENT SUPPLIER	WEIGHT per unit lb (kg)	ARM in. (m)
	25 - EQUIPMENT - FURNISHINGS			
A	Cargo transportation capability :			
	- Partition net at frame 7	SOCATA	2.205 (1.00)	200.31 (5.088)
	- Partition net at frame 14	SOCATA	2.205 (1.00)	289.53 (7.354)
	- Stowing net	SOCATA	6.614 (3.00)	224.41 (5.700)
				or 275.59 (7.000)
	- Front stop	SOCATA	1.014 (0.46)	202.76 (5.150)
	- Rear shim	SOCATA	6.173 (2.80)	255.12 (6.480)
	(OPT70 25027A)			
A	Cargo transportation capability :			
	- Partition net at frames 7/10	SOCATA	5.071 (2.30)	219.09 (5.57)
	- Partition net at frame 14	SOCATA	2.205 (1.00)	289.53 (7.354)
	(OPT70 25027B)			
S	Seats (oxygen equipment excluded) – 6-seat configuration			
	. R.H. front seat	SOCATA	29.696 (13.470)	182.68 (4.640)
	. Intermediate (back to flight direction)	SOCATA	25.507 (11.570)	218.31 (5.545)
	. Rear double chair	SOCATA	57.319 (26.000)	271.30 (6.891)

S A or O	STANDARD OR OPTIONAL EQUIPMENT	EQUIPMENT SUPPLIER	WEIGHT per unit lb (kg)	ARM in. (m)
S	Stairway	SOCATA	9.921 (4.500)	252.36 (6.410)
S	Cabin and baggage compartment carpets	SOCATA	23.369 (10.600)	234.02 (5.944)
A	JEPPESEN cabinet - Composite (OPT70 25005C)	SOCATA	14.991 (6.800)	202.76 (5.150)
A	Storage cabinet - Composite (OPT70 25006E)	SOCATA	16.314 (7.400)	202.76 (5.150)
A	Refreshment cabinet - Composite (OPT70 25006F)	SOCATA	18.960 (8.600)	202.76 (5.150)
A	Audio cabinet - Composite (OPT70 25009C)	SOCATA	24.052 (10.910)	206.14 (5.236)

WEIGHT AND BALANCE DETERMINATION

Enter the basic empty weight of the airplane in normal configuration and the moment in the appropriate block on the Loading Form, Figure 9.30.2 (1/3).

Use Figure 9.30.1 to determine the weight and moment difference for the conversion to the cargo version. Enter the weight and moment difference for the conversion in the appropriate block on the Loading Form, Figure 9.30.2 (1/3).

Enter the weight of all the crew and the loaded cargo in the appropriate block on the Loading Form, Figure 9.30.2 (1/3).

Determine the moment for each occupant.

Determine the moment for the cargo according to the position of the C.G. arm from Figure 9.30.1.

Enter the moment of each item in the appropriate blocks on the Loading Form, Figure 9.30.2 (1/3).

Add the weight and moment of all the items to the basic empty weight and moment of the airplane to determine the zero fuel weight and moment. Divide the moment by the weight to determine the C.G. arm “do”.

Determine the moment of the fuel load.

Enter the fuel weight and moment in the appropriate block on the Loading Form, Figure 9.30.2 (1/3) and proceed as for the zero fuel configuration.

Add the fuel weight and moment to the here above calculated zero fuel weight and moment to determine the weight with fuel and moment. Divide the moment by the weight to determine the C.G. arm.

Express the C.G. arms “do” in percentage of the aerodynamic chord according to the formula and complete the table, Figure 9.30.2 (2/3) or (3/3).

Enter the characteristics of the loaded airplane in blocks ① for the zero fuel and weight with fuel configurations, Figure 9.30.3.

Calculate the basic index using the formula described in ② and enter the results in ③, Figure 9.30.3.

Enter the calculated index ③ in the upper index scale and proceed according to the method described in Figure 9.30.3.

Draw a vertical line corresponding to the final index (loaded airplane) until you reach the airplane weight horizontal line.

Read the corresponding balance while checking that the obtained point falls within the weight and balance envelope. Also check that the total zero fuel weight does not exceed the max. zero fuel weight [6001 lbs (2722 kg)].

Otherwise, reconsider the airplane loading.

Record these data on your navigation log.

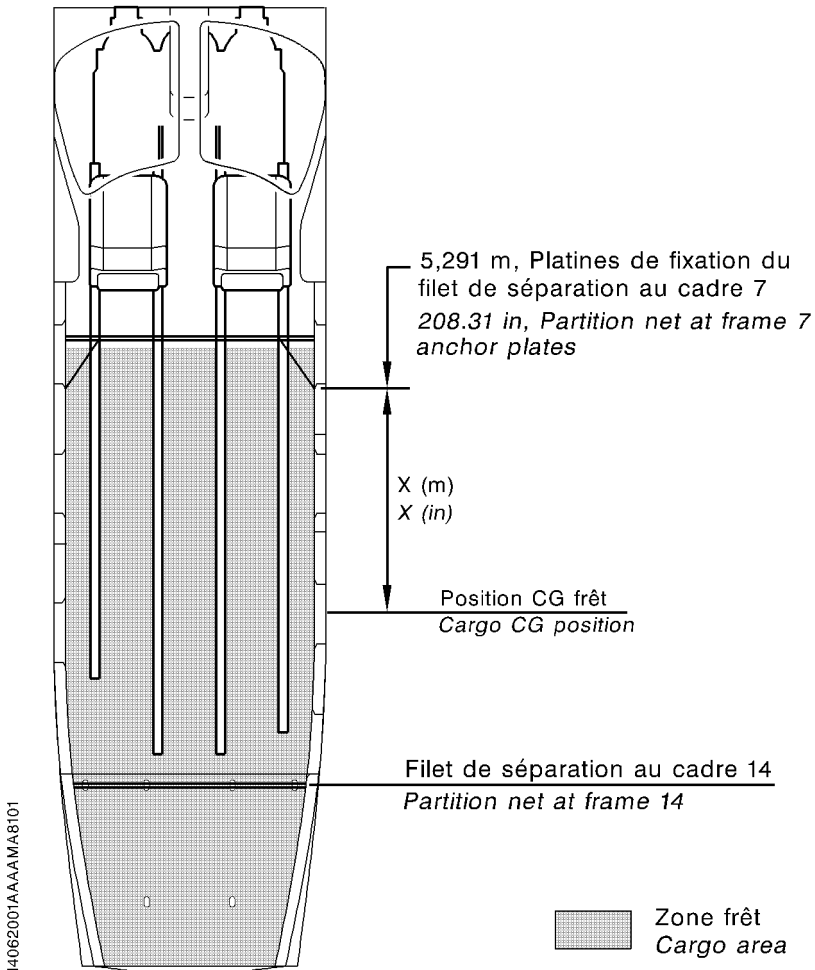

Measure the cargo CG position (x dimension) from the anchor plates at frame 7.

Express the cargo CG arm according to the following formula :

$$do = 208.31 + x \quad (\text{in})$$

or

$$do = 5.291 + x \quad (\text{m})$$

Figure 9.30.1 - CG arm calculation

LOADING FORM			
ITEM	WEIGHT	C.G. ARM	MOMENT
	lb (kg)	in (m)	lb.in (m.kg)
1. Basic empty weight			
2. Cargo conversion			
3. Pilot		180.5 (4.585)	
4. R.H. seat passenger		180.5 (4.585)	
5. Front baggage		128.0 (3.250)	
6. Cargo			
7. Cargo			
8. Cargo			
9. Cargo			
10. Rear baggage		303.0 (7.695)	
11. Zero fuel weight			
12. Fuel		188.19 (4.780)	
13. Weight with fuel			

Figure 9.30.2 (1/3) - Loading Form

$$\text{CG m.a.c. \%} = \frac{(d_o - 172.93)}{59.45} \times 100$$

ITEM	WEIGHT lb	do in	CG m.a.c. %
14. Zero fuel weight			
15. Weight with fuel			

Figure 9.30.2 (2/3) - Loading Form (lbs and in)

$$\text{CG \% cam} = \frac{(d_o - 4.3925)}{1.51} \times 100$$

ITEM	WEIGHT kg	do m	CG m.a.c. %
14. Zero fuel weight			
15. Weight with fuel			

Figure 9.30.2 (3/3) - Loading Form (kg and m)

①	②	③
Airplane weight (W)	CG (MAC %)	Index calculation
		$I = \frac{(CG - 28) W}{1323} + 80$
		Basic index

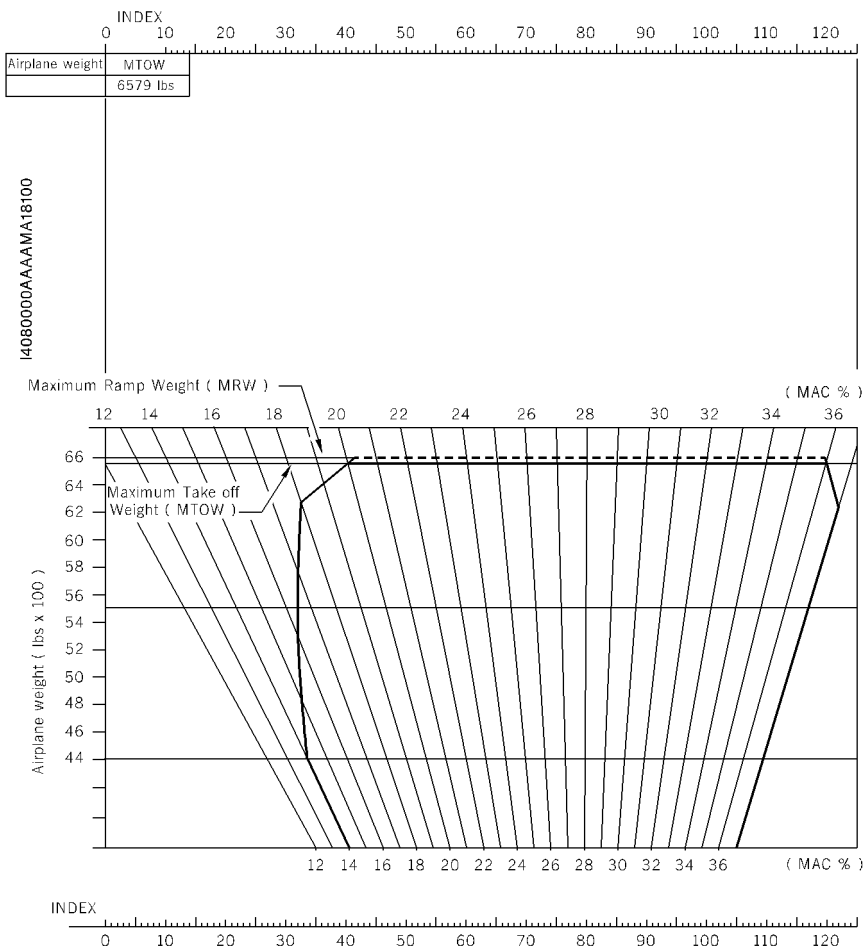

Figure 9.30.3 - Weight and balance graph (in lbs)

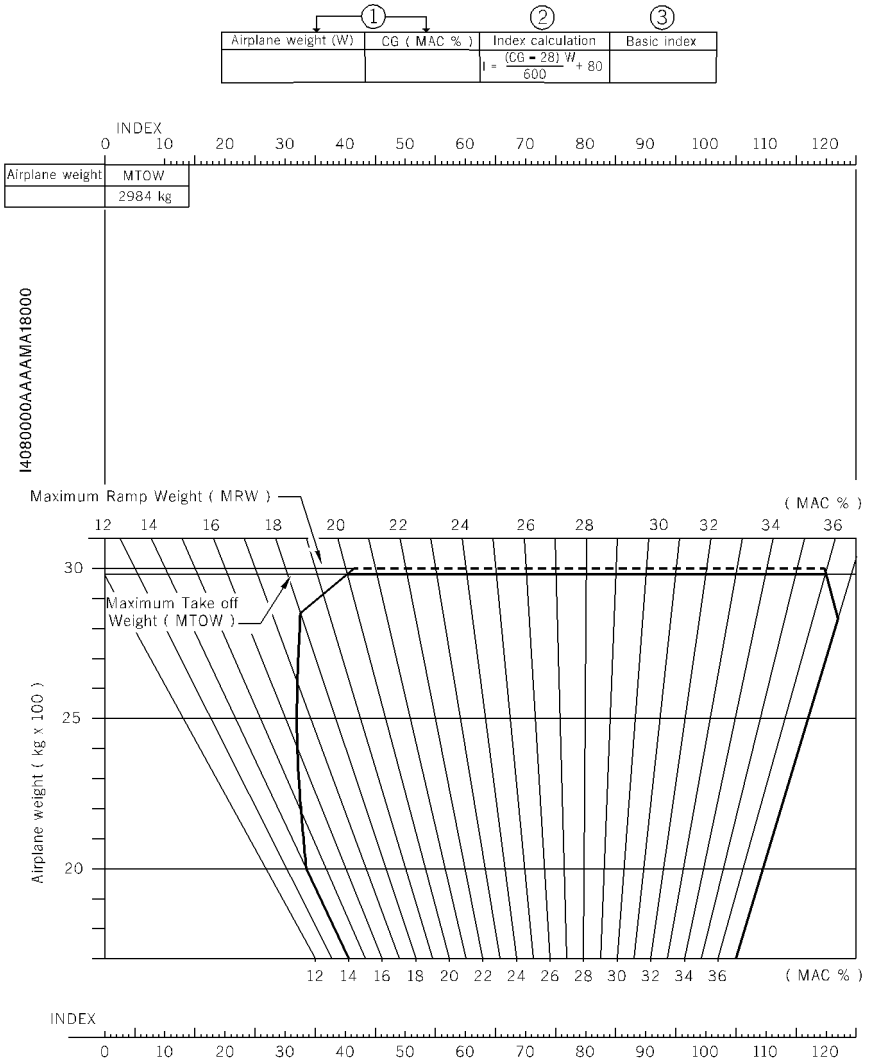

Figure 9.30.3A – Weight and balance graph (in kg)

SECTION 7

DESCRIPTION

DESCRIPTION

For transport of goods in bulk (cargo of low density), two partition nets are available :

- one net at frame 7 for cargo installed in the cabin with only a pilot on board or one net at frames 7/10 with a pilot and a R.H. passenger on board,
- one net at frame 14 for cargo installed in the baggage compartment aft of the cabin.

For transport of goods in container, on pallet or in heavy case, two identical stowing nets, with adjustable straps, are available. The strap ends are equipped with anchor fittings allowing their attachment to the seat rails or into anchor points provided in the baggage compartment.

LOADING INSTRUCTIONS

CAUTION

CARGO MUST BE STRAPPED ON THE PALLET FROM THE FRONT TO THE REAR PART OF THE CARGO

When positioned at the front, the container, pallet or heavy case must be installed against retaining angles attached to the seat rails and it must be stowed with one of the stowing nets attached to the anchor fittings in the seat rails.

When positioned at the rear, the container, pallet or heavy case must be stowed with the second stowing net attached to the anchor fittings in the seat rails, to the attachment fittings of standard straps in the baggage compartment and to the lower attachment fittings of the partition net at frame 14.

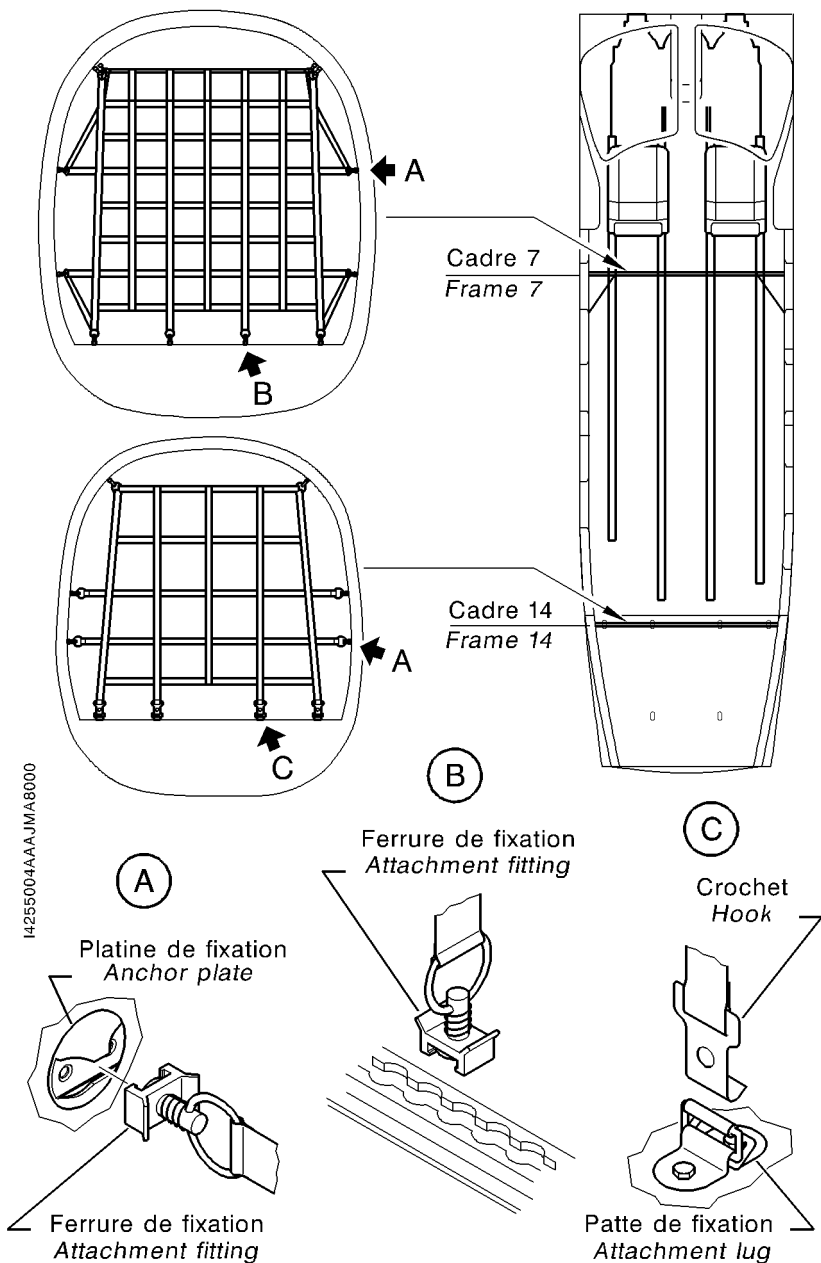
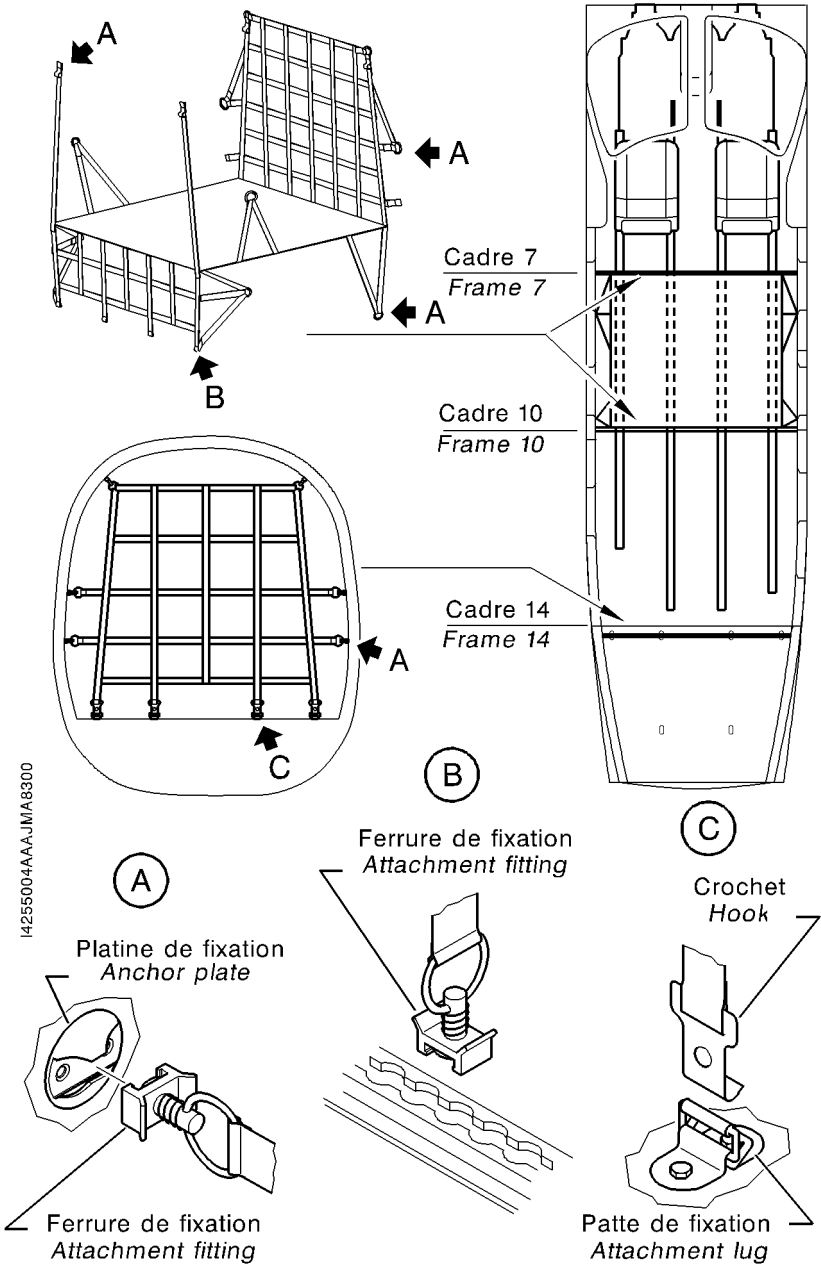

Figure 9.30.4 - Partition nets (version with a pilot)



14255004AAA/JMA/8300

Figure 9.30.4A - Partition nets (version with a pilot and a R.H. passenger)

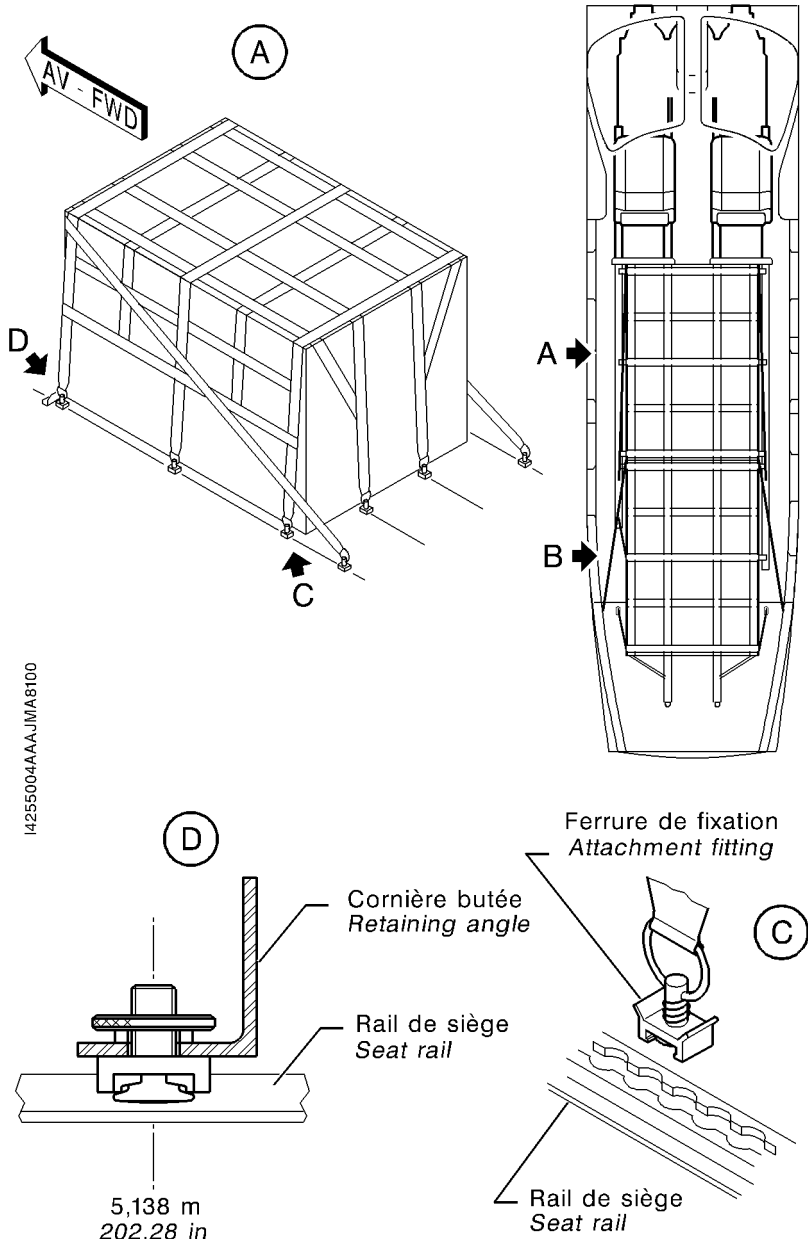

Figure 9.30.5 (1/2) - Stowing of front container, pallet or heavy box (pilot alone on board)

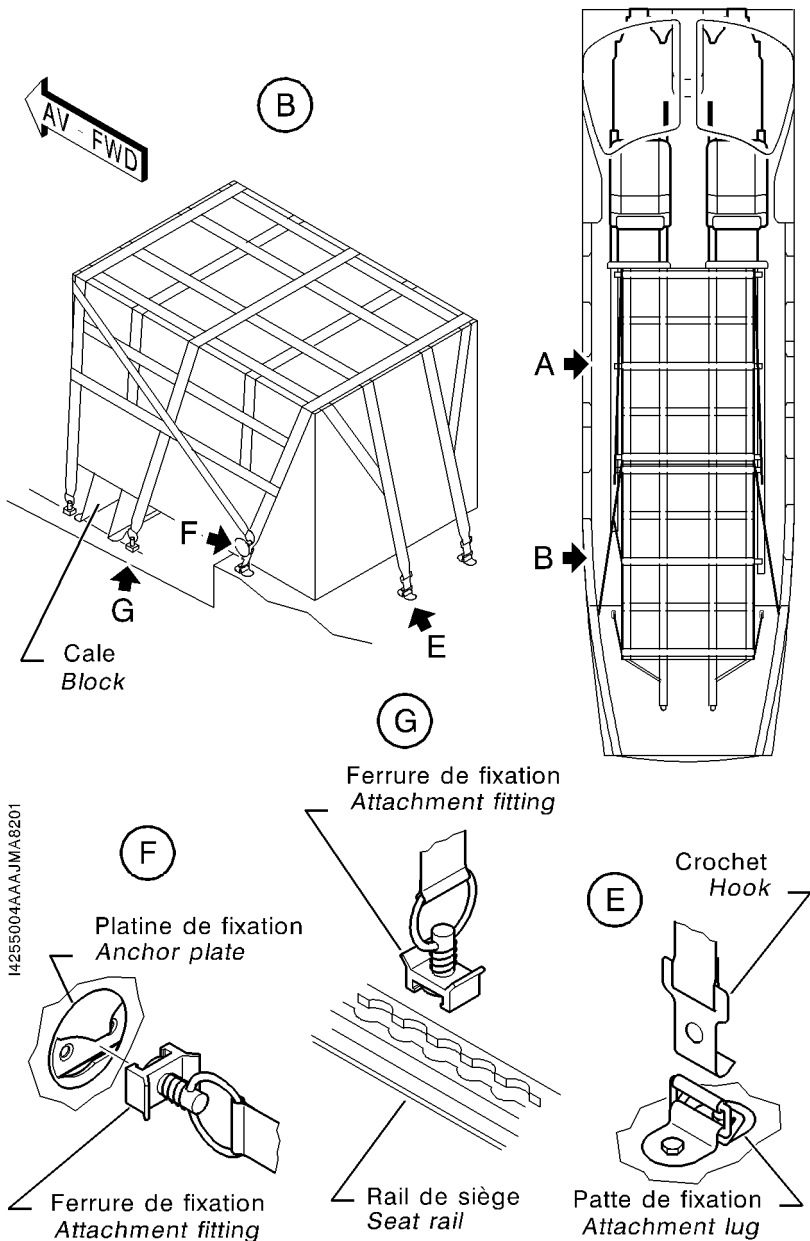

Figure 9.30.5 (2/2) - Stowing of rear container, pallet or heavy box (pilot alone on board)

SECTION 8**HANDLING, SERVICING AND MAINTENANCE****A - CONVERSION OF PASSENGERS ACCOMMODATION INTO CARGO TRANSPORTATION VERSION**

- 1) Remove the rear double chair and the intermediate passengers' seats.
- 2) If the airplane is equipped with the gaseous oxygen option, optionally remove the R.H. front seat.
- 3) If installed, remove the cabinets.
- 4) Remove the cabin and baggage compartment carpets.
- 5) If necessary, remove the stairs.

Bulk freight with a pilot

- 6) Attach the front partition net, P/N T700B259001100000.
- 7) Attach the rear partition net, P/N T700B259000100000.

Bulk freight with a pilot and a passenger

- 6) Attach the front partition net, P/N T700B259001800000.
- 7) Attach the rear partition net, P/N T700B259000100000.

Container, pallet or heavy box freight

- 6) Position and secure the retaining angles, P/N T700B259003100000.

CAUTION**CARGO MUST BE STRAPPED ON THE PALLET FROM THE FRONT TO THE REAR PART OF THE CARGO**

- 7) If a container, a pallet or a heavy box must be installed in aft location :
 - a) Remove both attachment lugs and the rings in airplane centerline at the level of frame 14.
 - b) Position and secure the block, P/N T700B259001500000.
- 8) After having loaded the airplane, position and secure the stowing nets, P/N T700B259001300000.

B - CONVERSION OF CARGO TRANSPORTATION VERSION INTO PASSENGERS ACCOMMODATION

- 1) If removed, install the stairs.
- 2) Remove and put away :
 - the stowing nets, P/N T700B259001300000,
 - the retaining angles, P/N T700B259003100000,
 - the front partition net, P/N T700B259001100000 or T700B259001800000,
 - if necessary, the rear partition net, P/N T700B259000100000,
 - the block, P/N T700B259001500000.
- 3) If removed, install both attachment lugs and the rings at the level of frame 14.
- 4) Install the cabin and baggage compartment carpets.
- 5) If removed, install the cabinets.
- 6) Install the intermediate passengers' seats and the rear double chair.
- 7) If removed, install the R.H. front seat.

SUPPLEMENT**“HONEYWELL” KMD 850**
MULTI-FUNCTION DISPLAY**TABLE OF CONTENTS**

	Page
1 - GENERAL	9.35.2
2 - LIMITATIONS	9.35.3
3 - EMERGENCY PROCEDURES	9.35.4
4 - NORMAL PROCEDURES	9.35.4
5 - PERFORMANCE	9.35.5
6 - WEIGHT AND BALANCE	9.35.5
7 - DESCRIPTION	9.35.6

“HONEYWELL” KMD 850
MULTI-FUNCTION DISPLAY**SECTION 1****GENERAL**

This supplement is intended to inform the pilot about the equipment limitations, description and operations necessary to the operation when the TBM 700 airplane is equipped with the option “HONEYWELL” KMD 850 MULTI-FUNCTION DISPLAY”.

The generalities hereafter supplement those of the standard airplane described in Section 1 “General” of the basic Pilot’s Operating Handbook, when the TBM 700 airplane is equipped with the option “HONEYWELL” KMD 850 MULTI-FUNCTION DISPLAY”.

The KMD 850 is a multifunction display screen which allows to display topographical type information (rivers, roads, ...), aeronautical type information (VOR, Airport, NDB, ...), as well as information issued from a weather radar, a stormscope, an EGPWS and the active flight plan issued from a GPS.

Aeronautical items of information are stored in a data card. This data base is updated every 28 days by replacing the data card.

**SECTION 2
LIMITATIONS**

The limitations hereafter supplement those of the standard airplane described in Section 2 "Limitations" of the basic Pilot's Operating Handbook, when the TBM 700 airplane is equipped with the option "HONEYWELL" KMD 850 MULTI-FUNCTION DISPLAY".

KMD 550/850 Multi-function Display Pilot's Guide, P/N 006-18222-0000, Revision 0 dated Oct/2000 or any applicable following edition, shall be readily available to the pilot.

The KMD 850 may be used only as an aid to navigation, if :

- navigation is based on other approved instruments,
- the KMD 850 data base is current and compatible with the flight,
- KMD 850 and associated GPS data bases cover the same geographical areas.

CAUTION

**KMD 850 TOPOGRAPHICAL DATA MUST NOT BE USED FOR
TERRAIN AND/OR OBSTACLES AVOIDANCE**

“HONEYWELL” KMD 850
MULTI-FUNCTION DISPLAY**SECTION 3**
EMERGENCY PROCEDURES

Installation and operation of the “HONEYWELL” KMD 850 Multi-function Display do not change the emergency procedures described in Section 3 “Emergency procedures” of the basic Pilot’s Operating Handbook.

SECTION 4
NORMAL PROCEDURES

The normal procedures hereafter supplement those of the standard aircraft described in Section 4 “Normal procedures” of the basic Pilot’s Operating Handbook, when the TB aircraft is equipped with the option “HONEYWELL” KMD 850 MULTI-FUNCTION DISPLAY”.

KMD normal operating procedures recommended by the manufacturer are outlined in the KMD 550/850 Multi-function Display Pilot’s Guide, P/N 006-18222-0000, Revision 0 dated Oct/2000 or any applicable following edition.

SECTION 5
PERFORMANCE

The installation and the operation of the “HONEYWELL” KMD 850 Multi-function Display do not change the basic performance of the airplane described in Section 5 “Performance” of the basic Pilot’s Operating Handbook.

SECTION 6
WEIGHT AND BALANCE

Information hereafter supplement the one given for the standard airplane in Section 6 “Weight and balance” of the basic Pilot’s Operating Handbook.

A or O	OPTIONAL EQUIPMENT	EQUIPMENT SUPPLIER	WEIGHT per unit lb (kg)	ARM in. (m)
A	34 - NAVIGATION Multi-function display KMD 850 (OPT70 34054)	HONEYWELL	6.415 (2.910)	153.54 (3.900)

**“HONEYWELL” KMD 850
MULTI-FUNCTION DISPLAY**

**SECTION 7
DESCRIPTION**

- | | |
|----------------------------------|-------------------------------------|
| 1 - Brightness control | 8 - Control knobs (inner and outer) |
| 2 - Data card | 9 - Power key labels |
| 3 - LCD display | 10 - Soft labels |
| 4 - Available function | 11 - Joystick |
| 5 - ON/OFF control | 12 - Power keys |
| 6 - Selected function indicators | 13 - Fault indicator |
| 7 - Function select keys | |

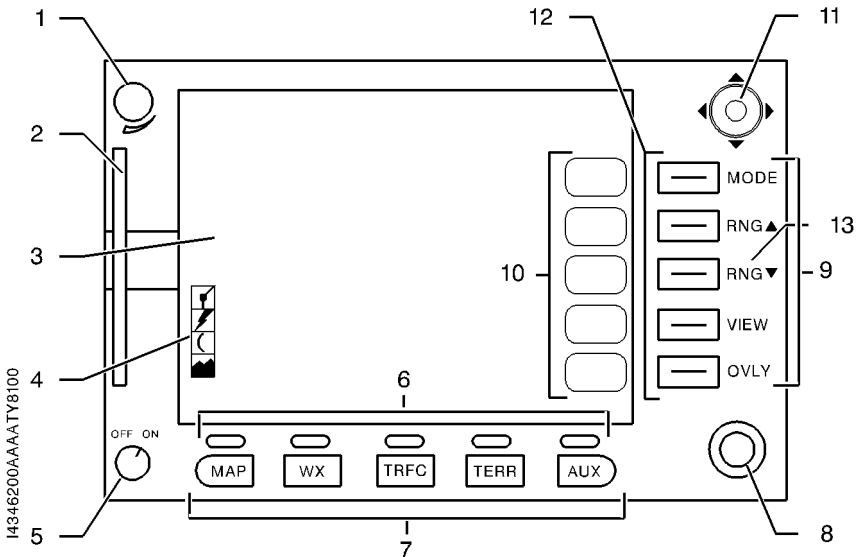

Figure 9.35.1 - KMD 850 Multi-function display (front view)

SUPPLEMENT**"GARMIN GNS 530" GPS
NAVIGATION SYSTEM (B-RNAV)
INTERFACED WITH EHSI OF EFS 40****TABLE OF CONTENTS**

	Page
1 - GENERAL	9.36.2
2 - LIMITATIONS	9.36.3
3 - EMERGENCY PROCEDURES	9.36.6
4 - NORMAL PROCEDURES	9.36.8
5 - PERFORMANCE	9.36.12
6 - WEIGHT AND BALANCE	9.36.12
7 - DESCRIPTION	9.36.13

**"GARMIN GNS 530" GPS NAVIGATION SYSTEM
(B-RNAV) INTERFACED WITH EHSI OF EFS 40**

SECTION 1**GENERAL**

This supplement is intended to inform the pilot about the equipment limitations, description and operations necessary to the operation when the TBM 700 airplane is equipped with the option "GARMIN GNS 530" GPS NAVIGATION SYSTEM (B-RNAV) INTERFACED WITH EHSI OF EFS 40".

Approved utilization types :

- IFR in continental and Terminal Enroute areas as additional source,
- B-RNAV,
- Non precision approaches (GPS, VOR, VOR-DME, TACAN, NDB, NDB-DME, RNAV).

Conformity means :

- ACJ 20X4 and ACJ 20X5
- AC 20-138.

The generalities hereafter supplement those of the standard airplane described in Section 1 "General" of the basic Pilot's Operating Handbook, when the TBM 700 airplane is equipped with the option "GARMIN GNS 530" GPS NAVIGATION SYSTEM (B-RNAV) INTERFACED WITH EHSI OF EFS 40".

This supplement does not constitute an operational utilization authorization.

The GPS is an automatic tridimensional (latitude, longitude, altitude) location and navigation means using information provided by satellites (the GNS 530 system is able to track up to 12 satellites at a time). It also uses data recorded in a data base. The data base is housed in a Navdata card to be inserted in the front face and is updated every 28 days by replacing the card.

Each data base contains information about airports, communication frequencies, VORs, NDBs, Intersections, SIDs, STARs, instrument approaches, flight service stations ...

There is also room for up to 1000 user defined waypoints and 20 different flight plans.

SECTION 2 LIMITATIONS

2.1 - General

The limitations hereafter supplement those of the standard airplane described in Section 2 "Limitations" of the basic Pilot's Operating Handbook, when the TBM 700 airplane is equipped with the option ""GARMIN GNS 530" GPS NAVIGATION SYSTEM (B-RNAV) INTERFACED WITH EHSI OF EFS 40".

"GARMIN" GNS 530 Pilot's Guide, P/N 190-00181-00 Revision A dated 04/00 or any applicable following edition, shall be readily available to the pilot, each time the GPS navigation system is used.

The system must utilize the following software versions or more recent ones :

Subsystem	Software
MAIN	2.06
GPS	2.10

■ Data base updating must be verified before each flight.

The navigation sources required for the anticipated flight shall be serviceable and allow an immediate crossed check on available ground aids or shall allow to return to primary navigation sources in case of GPS navigation loss.

Use of GPS as a navigation source is **PROHIBITED**, unless the pilot verifies the currency of the data base and the coordinates of each selected waypoint.

**"GARMIN GNS 530" GPS NAVIGATION SYSTEM
(B-RNAV) INTERFACED WITH EHSI OF EFS 40**

Procedures during flight preparation

During flight preparation, the pilot must get information about GPS constellation, via aeronautical data (consultation of GPS NOTAM).

When less than 24 satellites are available (or less than 23 if equipment uses pressure altitude information), the pilot must make sure that RAIM function is available on the projected route and for the flight period in B-RNAV areas.

RAIM function prediction can be done using prediction software integrated into GNS 530 or any other approved software such as the one provided for the users by EUROCONTROL on INTERNET.

If a loss of RAIM function is predicted on the chosen route for a period of more than 5 minutes, the flight cannot be done. In that case, the flight will either be postponed or another route will be chosen. The prediction software must then be used again.

Preflight procedures

During preflight checks, it is necessary to verify data base validity (updating of the last AIRAC cycle).

The onboard equipment must be initialized in compliance with manufacturer procedures (refer to "GARMIN GNS 530 Pilot's Guide").

In case a pre-programmed or an already stored flight plan is used, an accurate check of the waypoints is also required.

General in-flight procedures

Before entering a B-RNAV area, the pilot must make sure that RAIM function is available.

Flight plan activation, WPT and LEG changes as well as any modification of initialization data must be done in compliance with equipment User's Manual.

For every navigation into areas reserved for B-RNAV, the pilot must be provided with a predicted availability of RAIM on the route, if the constellation disposes of less than 23 satellites.

The check of navigation system information consistency must be regularly performed during the flight :

- when reaching each waypoint or before reaching the position report point of the ATC,
- before leaving a published route and then every 15 minutes during this type of operation (function "Direct To").

The check of position information consistency may be performed by comparing this position with the one determined by the primary radionavigation sources.

2.2 - SID/STAR

The use of SIDs and STARs stored in GPS data base is only authorized, if the pilot has checked that GPS procedure corresponds to the one given in the official documentation (coordinates of various points and paths between points).

2.3 - Instrument approach (Non precision approach)

Use of the GPS to perform an instrument approach is possible, as long as this use is approved by the air navigation local authority for the approach in question.

Instrument approaches performed with the GPS must be achieved according to approved approach procedures given in the GPS data base. The data base must be kept up to date and base data accuracy checked with regard to the official documentation, preferably before the flight.

- a) Instrument approaches must be performed in GPS approach mode and the RAIM must be available at the final approach fix (FAF).
- b) Precision approaches (ILS, LOC, LOC-BC, MLS ...) must not be performed with the GPS.
- c) If a landing is required on a diversion field, an other means than GPS must be available to perform approach to this field. Required on board equipment must be serviceable and ground aids must be operational.

Instrument approaches can only be performed, as long as used point coordinates are referenced with regard to WGS 84 system or an equivalent system.

**"GARMIN GNS 530" GPS NAVIGATION SYSTEM
(B-RNAV) INTERFACED WITH EHSI OF EFS 40**

**SECTION 3
EMERGENCY PROCEDURES**

The emergency procedures hereafter supplement those of the standard airplane described in Section 3 "Emergency procedures" of the basic Pilot's Operating Handbook, when the TBM 700 airplane is equipped with the option ""GARMIN GNS 530" GPS NAVIGATION SYSTEM (B-RNAV) INTERFACED WITH EHSI OF EFS 40".

EHSI NAV FLAG

In navigation GPS#1 (OPT70-23024) :

Return to VOR, ADF or (if installed) GPS#2 navigation sources and to remaining operational navigation equipment.

Selection of GPS#2 (if installed and BRNAV authorized) **PRESS ONCE**
on "1-2" push-button of the EHSI

or

Selection of VOR or ADF **PRESS ONCE or TWICE**
on "NAV" push-button of the EHSI

In navigation GPS#2 (OPT70-23025) :

Return to VOR, ADF or GPS#1 navigation sources and to remaining operational navigation equipment.

Selection of GPS#1 (if BRNAV authorized) **PRESS ONCE**
on "1-2" push-button of the EHSI

or

Selection of VOR or ADF **PRESS ONCE or TWICE**
on "NAV" push-button of the EHSI

"MSG" ANNUNCIATOR ILLUMINATION

In navigation with GPS associated to the warning :

"MSG" push-button of associated GPS **PRESS**

Check the message.

NOTE :

A single "stand-alone" GPS certified as B-RNAV navigation means is required to fly in B-RNAV areas.

In case of loss of RAIM function, the navigation information remains available but its integrity is no longer controlled.

- If RAIM loss occurs out of B-RNAV area, the aircraft must not enter B-RNAV area.
- If RAIM loss occurs in B-RNAV area, GPS navigation can be continued as long as cross-checkings done with conventional means (VOR, DME, NDB and dead reckoning elements) enable making sure that B-RNAV accuracy criteria are observed. When this condition is not met, the Air Traffic Control must be contacted to return to conventional navigation.

If GPS navigation information is lost or declared not valid, use the other available navigation means. If this occurs during instrument approach final phase, a go-around must be made, except if the other approved radio means to perform approach are displayed and available.

**"GARMIN GNS 530" GPS NAVIGATION SYSTEM
(B-RNAV) INTERFACED WITH EHSI OF EFS 40****SECTION 4
NORMAL PROCEDURES**

The normal procedures hereafter supplement those of the standard airplane described in Section 4 "Normal procedures" of the basic Pilot's Operating Handbook, when the TBM 700 airplane is equipped with the option "GARMIN GNS 530" GPS NAVIGATION SYSTEM (B-RNAV) INTERFACED WITH EHSI OF EFS 40".

Normal operating procedures of the GPS recommended by the manufacturer are outlined in the "GARMIN" GNS 530 Pilot's Guide at the latest revision and Memory Jogger at the latest revision.

However, it is important to precise the following points for the GPS use on TBM 700 :

SET UP CONDITIONS

- Verify if the data base is current. Verify data on the self test page.
- Verify that altitude data is valid for the GPS prior to flight.
- In case of B-RNAV use :

During the preflight planning phase, the availability of GPS integrity (RAIM) shall be confirmed for the intended flight (route and time).

B-RNAV flight dispatch shall not be made in the event of a continuous loss of RAIM for more than 5 minutes predicted in any part of the intended flight.

When less than 24 satellites are available (or less than 23 if equipment uses pressure altitude information), the pilot must make sure that RAIM function is available on the projected route and for the flight period in B-RNAV areas.

When 23 or more satellites are available, the prediction of satellite position is valid for 7 days. Their predicted availability is ensured for 48 hours by EUROCONTROL.

When less than 23 satellites are available, the predicted availability of RAIM shall be confirmed short before each flight.

SYSTEM ANNUNCIATORS / SWITCHES / CONTROLS

"CDI" push-button of the GPS

This push-button may be used to select data to be displayed on electromechanical instruments (CDI or HSI).

This push-button is ineffective on the EHSI.

EHSI presentation "NAV" push-button

This push-button may be used to select data for presentation on the pilot's EHSI ; either NAV data from NAV 1 or NAV 2 navigation receiver or GPS#1 or (if installed) GPS#2 data or ADF data.

"NAV" symbol is green, "GPS1" symbol is blue, "GPS2" symbol is yellow and "ADF" symbol is green.

Colors relative to EHSI symbols are as follows :

CONFIGURATION	TEXTS	LEG OR NEEDLE
GPS1	Blue	Active leg : Blue Not active leg : White
GPS2	Yellow	Active leg : Yellow Not active leg : White
ADF	Green	Magenta
VOR1	Green	White
VOR2	Yellow	Magenta
LOC1	Green	Green
LOC2	Yellow	Yellow

**"GARMIN GNS 530" GPS NAVIGATION SYSTEM
(B-RNAV) INTERFACED WITH EHSI OF EFS 40**

"MSG" message annunciator

CAUTION

"MSG" ANNUNCIATOR MAY BE PERMANENTLY ILLUMINATED IF THERE EXISTS A PERMANENT MESSAGE. WHEN A NEW MESSAGE APPEARS, "MSG" ANNUNCIATOR JUST FLASHES.

"MSG" message annunciator will flash to alert the pilot of a situation that requires his attention. Press the **"MSG" push-button** located on the GPS to view the message (Chapter 12 of "GARMIN" GNS 530 Pilot's Guide contains a list of all the messages likely to appear on the "Message" page and their meanings).

"MSG" message annunciator (white color) of the GPS system interfaced with EHSI is displayed on the L.H. side of the EHSI. **"MSG1" message annunciator** of GPS#1 system (OPT70-23024) and/or **"MSG2" message annunciator** of GPS#2 system (OPT70-23025) are displayed on L.H. instrument panel (amber indication - see Figure 9.36.1, Detail A).

"WPT" Waypoint annunciator

This annunciator illuminates 10 seconds before warning "TURN TO XXX".

"WPT" Waypoint annunciator is also displayed on the L.H. side of the EHSI.

"APR" annunciator is also displayed on the L.H. side of the EHSI.

Flight director/autopilot coupled operation

The EHSI may be coupled with KFC 325 autopilot.

Engaging the "NAV" mode on the autopilot mode controller will make the FD appear on the EADI. The FD uses selected course and left/right steering information presented on the EHSI.

This information is related to the navigation source (VOR, GPS or ADF) selected by the push-button "NAV" on the EHSI.

When "AP" is engaged on the mode controller, the autopilot is then coupled to the EHSI and uses displayed information (track and course deviation).

When the GPS suspends the linked navigation (GPS "SUSP" annunciator), the autopilot continues keeping same heading.

NOTE :

When the EHSI is selected on GPS navigation source, the RMI remains selected on NAV 1 source (VOR or RNAV).

REMARK :

The change of steering source for the autopilot, when the latter is set to "NAV" side mode, implies a sequence of checks, some of which may be omitted or require a particular attention. Therefore it is strongly recommended to temporarily disengage the autopilot "NAV" mode before changing source.

GPS flight plan

In the active flight plan, addition of a STAR or an approach is always made at the end of the flight plan. In the scope of these additions, the pilot must pay attention not to duplicate points.

Non precision approach with coupled autopilot

The EHSI must be set in "HSI Compass Rose" mode.

Coupling with autopilot must be made in "NAV" mode, except in the following cases :

- holding pattern,
 - landing pattern turn,
 - interrupted approach,
- which have to be made in "HDG" mode.

For memory, the approach particular point name in the GARMIN system is as follows :

- IA = IAF
- FA = FAF ou FAP
- MA = MAP
- MH = MAHP

**"GARMIN GNS 530" GPS NAVIGATION SYSTEM
(B-RNAV) INTERFACED WITH EHSI OF EFS 40**

**SECTION 5
PERFORMANCE**

The installation and the operation of the "GARMIN GNS 530" GPS NAVIGATION SYSTEM (B-RNAV) INTERFACED WITH EHSI OF EFS 40 do not change the basic performance of the airplane described in Section 5 "Performance" of the basic Pilot's Operating Handbook.

**SECTION 6
WEIGHT AND BALANCE**

Information hereafter supplement the one given for the standard airplane in Section 6 "Weight and balance" of the basic Pilot's Operating Handbook.

A or O	OPTIONAL EQUIPMENT	EQUIPMENT SUPPLIER	WEIGHT per unit lb (kg)	ARM in. (m)
23 - COMMUNICATIONS				
A	COM-NAV-GPS # 1 GNS 530 (B-RNAV) interfaced with EHSI (OPT70 23024)	GARMIN	- 1.852 (- 0.840)	169.13 (4.296)
A	COM-NAV-GPS # 2 GNS 530 interfaced with GI 106A CDI and EHSI (OPT70 23025)	GARMIN	1.852 (0.840)	143.15 (3.636)

**SECTION 7
DESCRIPTION**

Normal operating procedures of the "GARMIN GNS 530" GPS NAVIGATION SYSTEM (B-RNAV) INTERFACED WITH EHSI OF EFS 40 are described in the "GARMIN" GNS 530 Pilot's Guide at the latest revision.

7.1 "GNS 530 System # 1" OPTION (OPT70-23024)

The option includes the GPS#1 system consisting of :

- - one "GNS 530" GPS - see Figure 9.36.1 :
This GPS may be a navigation source for the autopilot. Course deviation information is then displayed on the EHSI.
- one "MSG1" repeater on pilot's instrument panel.

7.2 "GNS 530 System # 2" OPTION (OPT70-23025)

The option includes the GPS#2 system consisting of :

- - one "GNS 530" GPS - see Figure 9.36.1 :
This GPS may be a navigation source for the autopilot. Course deviation information is then displayed on the EHSI.
- one GI 106A CDI,
- one "MSG2" repeater on pilot's instrument panel.

**"GARMIN GNS 530" GPS NAVIGATION SYSTEM
(B-RNAV) INTERFACED WITH EHSI OF EFS 40**

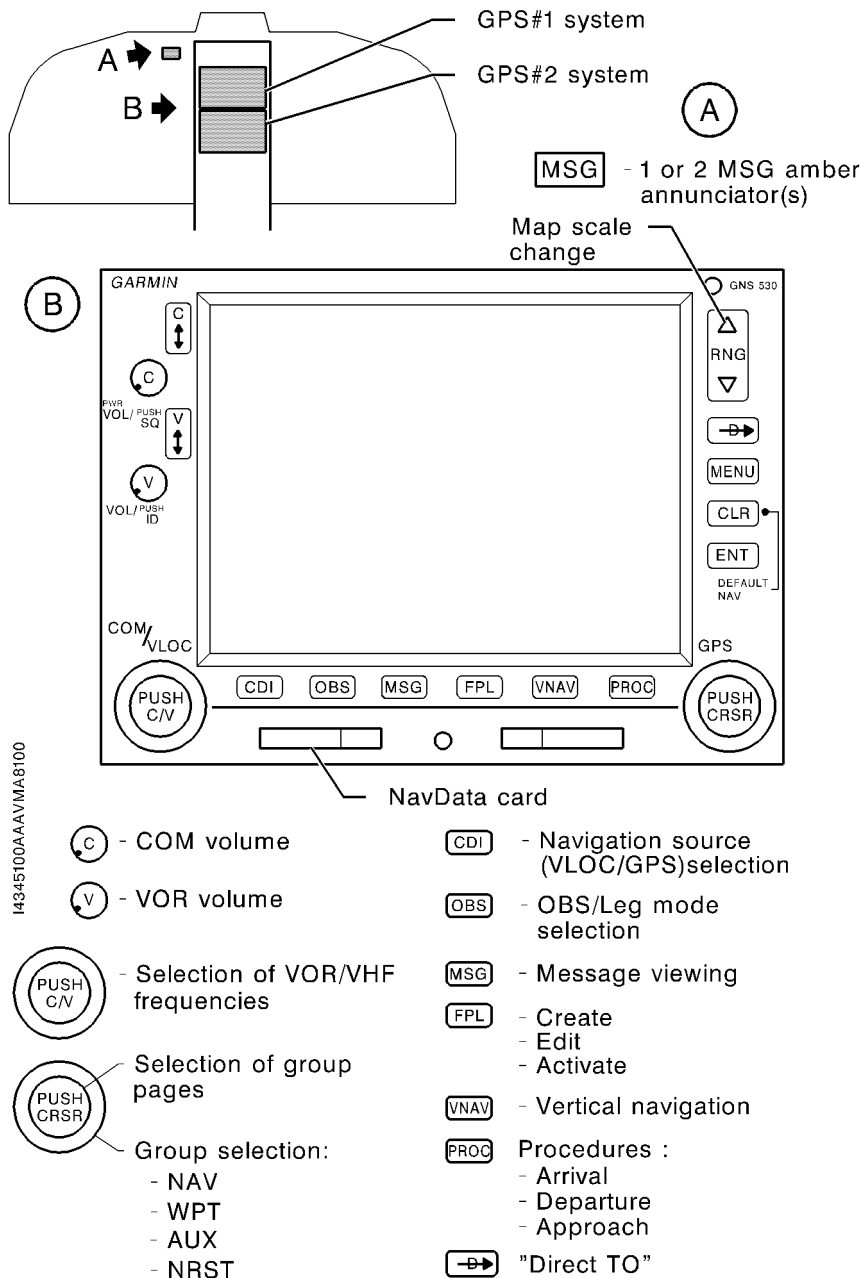

14345100AAA VMA8100

Figure 9.36.1 - "GARMIN GNS 530" GPS SYSTEMS

SUPPLEMENT

**KGP 560 "HONEYWELL"
EGPWS SYSTEM**

TABLE OF CONTENTS

	Page
1 - GENERAL	9.39.2
2 - LIMITATIONS	9.39.2
3 - EMERGENCY PROCEDURES	9.39.3
4 - NORMAL PROCEDURES	9.39.4
5 - PERFORMANCE	9.39.6
6 - WEIGHT AND BALANCE	9.39.6
7 - DESCRIPTION	9.39.7

SECTION 1

GENERAL

This supplement is intended to inform the pilot about the equipment limitations, description and operations necessary to the operation when the TBM 700 airplane is equipped with the option "KGP 560 "HONEYWELL" EGPWS SYSTEM".

The EGPWS system is an aid for the pilot enabling him to detect if the airplane path is in compliance with the overflowed terrain relief.

SECTION 2

LIMITATIONS

The limitations hereafter supplement those of the standard airplane described in Section 2 "Limitations" of the basic Pilot's Operating Handbook, when the TBM 700 airplane is equipped with the option "KGP 560 "HONEYWELL" EGPWS SYSTEM".

Following documents or any further edition applicable to the latter, shall be readily available to the pilot, each time the EGPWS system is used.

- KMD 550/850 Multi-function Display Pilot's Guide, P/N 006-18222-0000 Revision 1 dated April/2001,
- KMD 550/850 Multi-function Display/Terrain Function (EGPWS) Pilot's Guide Addendum, P/N 006-18236-0000 Revision 1 dated April/2001,
- KGP 560 General aviation Enhanced Ground Proximity Warning System - TSO C151a Class B - Pilot's Guide, P/N 006-18254-0000 Revision 1.

The EGPWS system provides terrain proximity alerting and detection to the pilot. It must not be used for airplane vertical and horizontal navigation.

AC 2318 recommendation : in order to avoid unwillingly warnings, the EGPWS must be inhibited for any landing on a terrain which is not mentioned in the data base.

SECTION 3
EMERGENCY PROCEDURES

The emergency procedures hereafter supplement those of the standard airplane described in Section 3 "Emergency procedures" of the basic Pilot's Operating Handbook, when the TBM 700 airplane is equipped with the option "KGP 560 "HONEYWELL" EGPWS SYSTEM".

WARNING LIGHT "TERR N/A" ON

1 - MD41 "TEST" switch **PUSH**

If the following voice message is heard :

"EGPWS Computer OK - External faults : Display configuration"

or

"EGPWS Computer OK - External faults : Display bus inactive" :

2 - Check the KMD 850 is set to ON.

For all other messages :

The EGPWS system is not operational.

SECTION 4
NORMAL PROCEDURES

The normal procedures hereafter supplement those of the standard airplane described in Section 4 "Normal procedures" of the basic Pilot's Operating Handbook, when the TBM 700 airplane is equipped with the option "KGP 560 "HONEYWELL" EGPWS SYSTEM".

BEFORE TAKEOFF	
1 - MD41 "TEST" switch	PUSH
2 - "EGPWS System OK" voice message	HEARD

4.1 - WARNINGS

"PULL UP" AURAL WARNING
The red "TERR" warning light illuminates.
1 - Level the wings.
2 - Display the maximum power.
3 - Choose the optimum rate of climb adapted to airplane configuration and speed, until the warning disappears.

"Terrain Terrain Pull up", "Obstacle Obstacle Pull up", AURAL WARNINGS
The red "TERR" warning light illuminates.
Adjust airplane path in order to make the warning disappear.

4.2 - CAUTIONS**"Caution terrain", "Caution obstacle",
"Too low terrain"
AURAL WARNINGS**

The amber "TERR" warning light illuminates.

Adjust airplane path in order to make the warning disappear.

"DON'T SINK" AURAL WARNING

The amber "TERR" warning light illuminates.

Re-establish a positive rate of climb.

"SINK RATE" AURAL WARNING

The amber "TERR" warning light illuminates.

Reduce rate of descent.

**SECTION 7
DESCRIPTION**

7.1 COMPONENTS OF THE OPTION

The EGPWS option is constituted of the following components :

- a KA 92 GPS antenna,
- a KGP 560 computer with integrated GPS,
- an MD41-1208 control box.

The KGP 560 information are displayed on a KMD 850 screen, when the "TERR" function is activated by the pilot. The GPS # 1 flight plan may be overlaid on the EGPWS display.

7.2 FUNCTIONS OF THE EGPWS SYSTEM

The EGPWS system has 5 functions :

- "Look ahead" function

This function provides a protection ahead of the airplane with a 1 minute prediction ("Caution terrain" or "Caution obstacle" aural warning associated with the illumination of the amber "TERR" warning light) and a 30 seconds prediction ("Terrain Terrain Pull up" or "Obstacle Obstacle Pull up" aural warning associated with the illumination of the red "TERR" warning light).

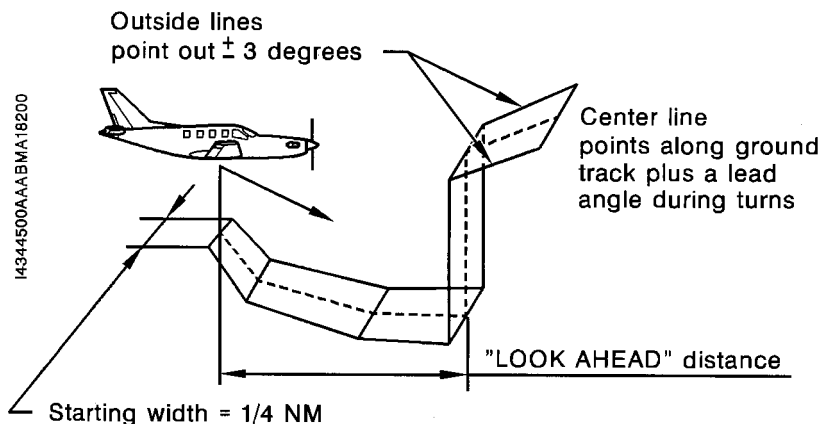

Figure 9.39.1

KGP 560 "HONEYWELL" EGPWS SYSTEM

- **"Runway Field Clearance Floor" (RFCF) function**

This function is active, when the airplane flies at less than 5 NM from a runway known in the KGP 560 data base ; it generates the "Too low terrain" aural warning and the illumination of the amber "TERR" warning light.

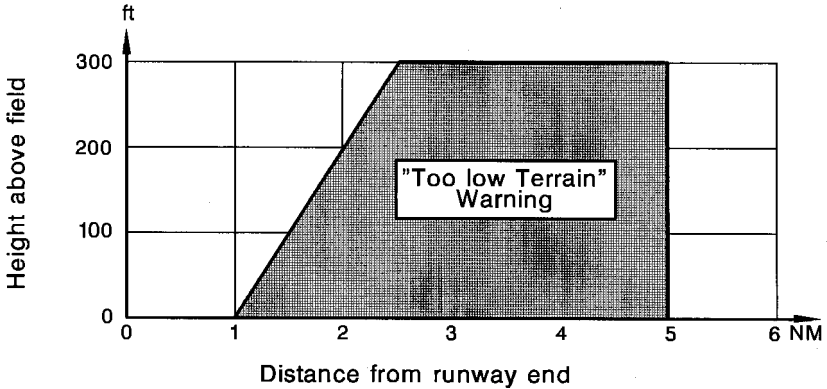

Figure 9.39.2 - "Too low terrain" warning area

- **"Excessive rate of descent" function**

This function has a lower priority than the "Look ahead" function ; it generates the "Sink rate" aural warning (illumination of the amber "TERR" warning light) and the "Pull up" aural warning (illumination of the red "TERR" warning light).

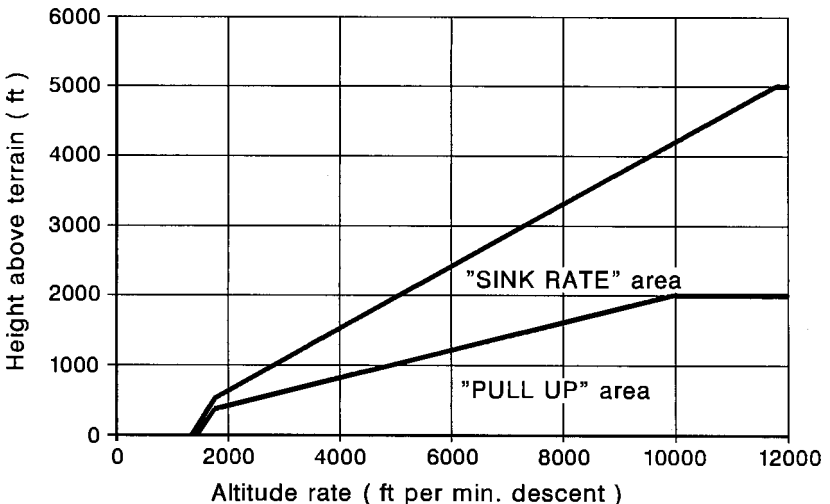

Figure 9.39.3 - "Sink rate" and "Pull up" warnings areas

- "Loss of altitude/negative rate of descent after takeoff" function

This function is active until the airplane reaches an altitude of approximately 700 ft above the runway ; it generates the "Don't sink" aural warning and the illumination of the amber "TERR" warning light.

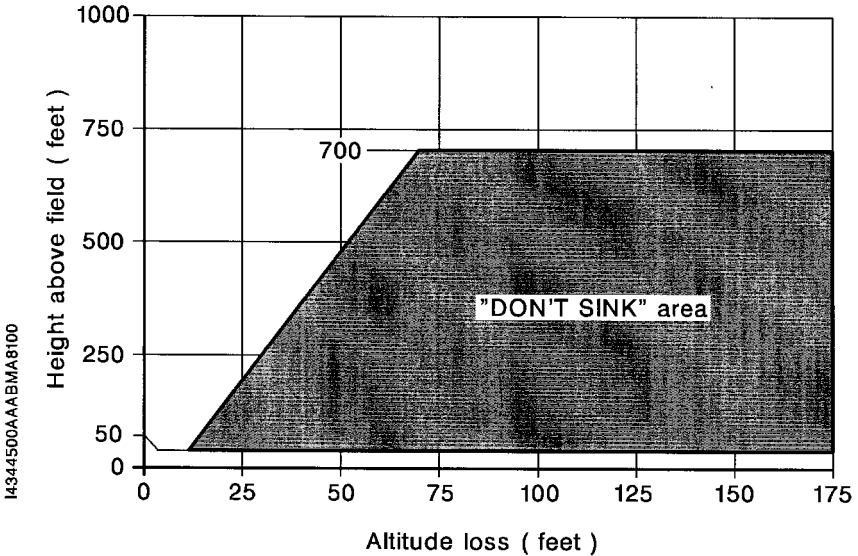
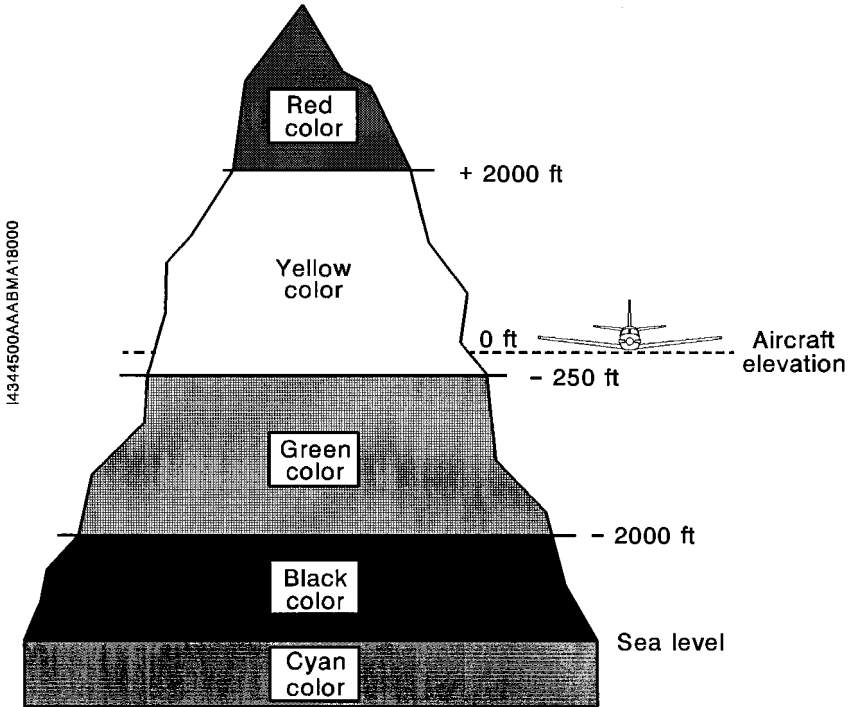

Figure 9.39.4 - "Don't sink" warning area

- "500 ft" function

This function is active, when the airplane flies at less than 5 NM from a runway known in the KGP 560 data base ; it generates a "500 ft" aural warning. This warning is re-initialized when the airplane reaches a height of 700 ft above the terrain altitude.

7.3 TERRAIN AWARENESS DISPLAY



7.4 OBSTACLE DATA BASE

Data for known obstacles such as towers, buildings, antennas, etc. is contained on the same data card as the terrain and airport data. Presently, there are some 70000-plus obstacles in the database, but they are all in the area of North America. As more reliable information becomes available, Honeywell will expand the capability to provide alerting and warning for obstacles in other areas of the world.

Obstacles in the database are those known obstacles more than 100 feet AGL, so obstacles of lower height will not produce GA-EGPWS "Obstacle" alerts or warnings. However, terrain elevations are "rounded" up to the next 100 feet, so alerting and warning protection is generally available for known obstacles that are less than 100 feet AGL.

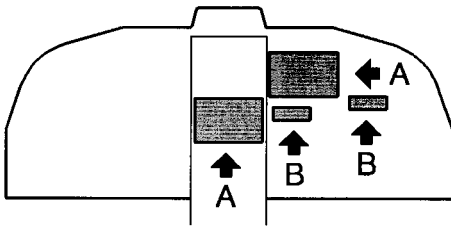

(A)

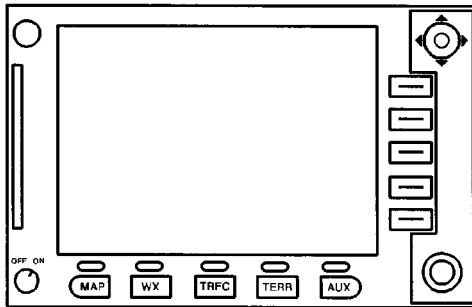

KMD 850

TERR : EGPWS mapping selection

(B)

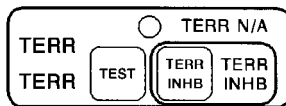

MD41 - 1208

TEST : EGPWS system test switch

TERR INHB : EGPWS warning inhibition switch

TERR (red) : Warnings

TERR (amber) : Cautions

TERR INHB (white) : Inhibited EGPWS warnings

TERR N/A (amber) : EGPWS system not operational

Figure 9.39.5 - EGPWS system

14344500AAAAMAB100

SUPPLEMENT

TBM 700C2

TABLE OF CONTENTS

		Page
1	- GENERAL	9.41.2A
	Descriptive data	9.41.2A
2	- LIMITATIONS	9.41.2A
	Weight and C.G. limits	9.41.2A
	Operation limits	9.41.2B
	Markings	9.41.2C
	Placards	9.41.3
3	- EMERGENCY PROCEDURES	9.41.5
	Engine failures	9.41.5
	Emergency landings	9.41.6
	Deicing system	9.41.10
4	- NORMAL PROCEDURES	9.41.11
	Airspeeds for normal operation	9.41.11
	Check-list procedures	9.41.11A
	Amplified procedures	9.41.15A
	Particular procedures	9.41.25
5	- PERFORMANCE	9.41.30
	Acoustic limitation	9.41.32
	Stall speeds	9.41.33
	Demonstrated crosswind	9.41.33
	Takeoff distances	9.41.34
	Climb performance	9.41.35
	Cruise performance	9.41.40
	Landing distances	9.41.65
6	- WEIGHT AND BALANCE	9.41.66
	General	9.41.66
	Determining weight and balance	9.41.66
	Determining empty airplane characteristics	9.41.69
	List of equipment	9.41.70
7	- DESCRIPTION	9.41.74
	Seats, belts and harnesses	9.41.74

TABLE OF CONTENTS (Continued)

8	- HANDLING, SERVICING AND MAINTENANCE	9.41.78
	Servicing	9.41.78
	Utilization by cold weather (- 0°C to - 25°C) or very cold weather (- 25°C to - 40°C)	9.41.78

SECTION 1**GENERAL**

This supplement is intended to inform the pilot about the limitations and procedures necessary to use the TBM 700C2 airplane :

- between 6579 lbs (2984 kg) and 7394 lbs (3354 kg) for takeoff weight, and/or
- between 6250 lbs (2835 kg) and 7024 lbs (3186 kg) for landing weight.

The TBM 700C2 modification consists of :

- new seats with integral belt and shoulder harnesses,
- reinforced main wheels and tires.

1.1 - DESCRIPTIVE DATA**SPECIFIC LOADINGS**

Wing loading : 38.16 lbs / sq.ft (186.3 kg / m²)

Power loading : 10.55 lbs / SHP (4.79 kg / SHP)

SECTION 2**LIMITATIONS**

The limitations hereafter supplement or replace those of the TBM 700C1 airplane described in Section 2 "Limitations" of the TBM 700C1 Pilot's Operating Handbook when using the TBM 700C2 airplane :

- between 6579 lbs (2984 kg) and 7394 lbs (3354 kg) for takeoff weight, and/or
- between 6250 lbs (2835 kg) and 7024 lbs (3186 kg) for landing weight.

2.1 - WEIGHT AND C.G. LIMITS**WEIGHT LIMITS**

Maximum ramp weight : 7430 lbs (3370 kg)

Maximum takeoff weight : 7394 lbs (3354 kg)

Maximum landing weight : 7024 lbs (3186 kg)

Maximum zero fuel weight (MZFW) : 6032 lbs (2736 kg)

Maximum baggage weight in pressurized compartment :

- with partition net version A : 100 lbs (45 kg)
- or
- with partition net version B : 220 lbs (100kg)

C.G. LIMITS (Figures 9.41.34 and 9.41.34A – Section 6 of this Supplement)

Center of gravity range with landing gear down and flaps up, attitude 0° :

Forward limits :

- 183.6 inches (4.664 m) aft of datum at 6250 lbs (2835 kg) (18 % of m.a.c)
- 185.3 inches (4.707 m) aft of datum at 6579 lbs (2984 kg) (20.85 % of m.a.c)
- 187 inches (4.752 m) aft of datum at all weights above 7024 lbs (3186 kg) (23.8 % of m.a.c)

Aft limits :

- 194.9 inches (4.951 m) aft of datum at all weights below 6250 lbs (2835 kg) (37 % of m.a.c.)
- 194.3 inches (4.936 m) aft of datum at 6579 lbs (2984 kg) (36 % of m.a.c.)
- 193.65 inches (4.921 m) aft of datum at 7394 lbs (3354 kg) (35 % of m.a.c.)

2.2 - OPERATION LIMITS
FLIGHT LOAD FACTOR LIMITS
Flaps up

Weight below 6579 lbs (2984 kg) :

$$- 1.5 \leq n \leq + 3.8 \text{ g}$$

Weight above 6579 lbs (2984 kg) :

$$- 1.5 \leq n \leq + 3.5 \text{ g}$$

Flaps down

$$- 0 \leq n \leq + 2.0 \text{ g}$$

2.3 - MARKINGS

AIRSPEED INDICATOR

Airspeed indicator markings and their color code significance are shown in Figure 9.41.1.

MARKING	KIAS (Value or range)	SIGNIFICANCE
White arc	65 – 122	Full Flap Operating Range Lower limit is maximum weight V_{SO} in landing configuration. Transition point between wide and narrow arcs is stall speed with flaps UP Upper limit is maximum speed permissible with flaps LDG
Wide	65 – 81	
Narrow	81 – 122	
Red line	266	Maximum speed for all operations

Figure 9.41.1 - AIRSPEED INDICATOR MARKINGS

INTENTIONALLY LEFT BLANK

2.4 - PLACARDS

Under L.H. front side window

I4113004AAKMA18000	FLIGHT CONDITIONS :		TBM700 C2		ICING CONDITIONS ALLOWED	
	DAY AND NIGHT VFR AND IFR		THIS AIRPLANE MUST BE OPERATED AS A NORMAL CATEGORY AIRPLANE IN COMPLIANCE WITH THE OPERATING LIMITATIONS STATED IN THE FORM OF PLACARDS, MARKINGS AND PILOT OPERATING HANDBOOK			
	INVERTED FLIGHT _____	PROHIBITED	MANEUVERING SPEED V_A _____	158 KIAS		
	ACROBATIC MANEUVERS _____	PROHIBITED	MAXIMUM OPERATING SPEED V_{MO} _____	266 KIAS		
	INTENTIONAL SPINS _____	PROHIBITED	FLAPS EXTENDED MAXIMUM SPEED V_{FE} _____			
	MAXIMUM TAKEOFF WEIGHT _____	3354 kg / 7394 lbs	TAKEOFF CONFIGURATION _____	178 KIAS		
	MAXIMUM LANDING WEIGHT _____	3186 kg / 7024 lbs	LANDING CONFIGURATION _____	122 KIAS		
	DESIGN LOAD FACTOR (MAXIMUM)		LANDING GEAR EXTENDED MAXIMUM SPEED V_{LE} _____	178 KIAS		
	FLAPS UP WEIGHT BELOW 2984 kg / 6579 lbs _____	$-1.5 \leq n \leq +3.8$ g	LANDING GEAR OPERATING MAXIMUM SPEED V_{LO} _____	128 KIAS		
	ABOVE 2984 kg / 6579 lbs _____	$-1.5 \leq n \leq +3.5$ g	UP _____	128 KIAS		
FLAPS DOWN _____	$0 \leq n \leq +2$ g	DOWN _____	178 KIAS			

On main gear leg

MAIN LANDING GEAR
TIRE PRESSURE : 8,96 bar
130 psi

On pressurized baggage compartment partition wall

With partition net version A (refer to Section 6 of TBM 700C1 Pilot's Operating Handbook)

I4113500AAAAMA8000	45 Kg - (100 lbs) MAXIMUM
	IT IS THE PILOT'S RESPONSIBILITY TO CHECK THAT ALL THE BAGGAGES ARE PROPERLY SECURED
	FOR LOADING INSTRUCTIONS SEE "WEIGHT AND BALANCE DATA" IN PILOT'S OPERATING HANDBOOK

With partition net version B (refer to Section 6 of TBM 700C1 Pilot's Operating Handbook)

I4112003AAABMA8200

100 kg - (220 lbs) MAXIMUM

IT IS THE PILOT'S RESPONSIBILITY TO CHECK THAT ALL THE BAGGAGES ARE PROPERLY SECURED.

FOR LOADING INSTRUCTIONS SEE "WEIGHT AND BALANCE DATA" IN PILOT'S OPERATING HANDBOOK AND GRAPH OPPOSITE.

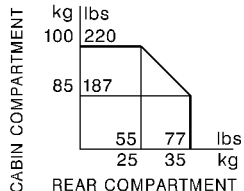

3.2 - EMERGENCY LANDINGS

FORCED LANDING (ENGINE CUT OFF)

- 1 - Power lever **IDLE**
- 2 - Propeller governor lever **FEATHER**
- 3 - Condition lever **CUT OFF**
- 4 - Tank selector **OFF**
- 5 - "AUX BP" fuel switch **OFF**
- 6 - "BLEED" switch **OFF**
- 7 - "AIR COND" switch **OFF**
- 8 - "DUMP" switch **ACTUATED**
- 9 - Glide speed **120 KIAS maintained until favourable ground approach**

If ground allows it :

- 10 - "ESS BUS TIE" reverse switch **NORMAL in order to have GEAR and FLAPS available**
- 11 - Landing gear **DN**

If night conditions :

- 12 - L.LDG / R.LDG **ON**

If ground does not allow it :

- 13 - Keep landing gear **UP**
- 14 - When chosen ground is assured **FLAPS LDG**
- 15 - CRASH lever **PULL DOWN**
- 16 - Final approach **IAS = 85 KIAS**
- 17 - Land flaring out
- 18 - EVACUATE after stop

3.2 - EMERGENCY LANDINGS

**LANDING WITH DEFECTIVE NOSE LANDING
GEAR (DOWN UNLOCKED OR NOT DOWN)**

- 1 - Transfer passengers to the rear, if necessary
- 2 - Approach **Flaps TO
IAS = 95 KIAS**
- 3 - Land with nose-up attitude, keep nose high
- 4 - Condition lever **CUT OFF**
- 5 - Propeller governor lever **FEATHER**
- 6 - Touch-down slowly with nose wheel and keep elevator at nose-up stop
- 7 - Moderate braking
- 8 - CRASH lever **PULL DOWN**
- 9 - EVACUATE after airplane comes to a stop

3.2 - EMERGENCY LANDINGS

LANDING WITH GEAR UP

1 - Final approach **Standard**
(Flaps LDG, IAS = 85 KIAS)

2 - "BLEED" switch **OFF**

3 - "DUMP" switch **ACTUATED**

When runway is assured :

4 - Power lever **IDLE**

5 - Propeller governor lever **FEATHER**

6 - Condition lever **CUT OFF**

7 - Tank selector **OFF**

8 - Flare out

9 - After touch-down, CRASH lever **PULL DOWN**

10 - EVACUATE after airplane comes to a stop

3.2 - EMERGENCY LANDINGS

LANDING WITH FLAPS MALFUNCTION**For flaps deflections from “UP” to “TO” position :**

Proceed as for a normal landing, maintaining approach airspeed :

Weight < 6250 lbs (2835 kg)	Weight > 6250 lbs (2835 kg)
IAS = 100 KIAS	IAS = 105 KIAS

Provide for a landing distance increased up to about 60 %

For flaps deflections greater than “TO” position :

Proceed as for a normal landing, maintaining approach airspeed :

Weight < 6250 lbs (2835 kg)	Weight > 6250 lbs (2835 kg)
IAS = 95 KIAS	IAS = 100 KIAS

Provide for a landing distance increased up to about 50 %

INTENTIONALLY LEFT BLANK

3.2 - EMERGENCY LANDINGS

DITCHING

- 1 - Landing gear **UP**
In heavy swell with light wind, land parallel to the swell (rollers).
In heavy wind, land facing wind.
- 2 - Flaps **LDG**
- 3 - Maintain a descent rate as low as possible when approaching the water
- 4 - Airspeed **IAS = 85 KIAS**
- 5 - "BLEED" switch **OFF**
- 6 - "DUMP" switch **ACTUATED**
- 7 - CRASH lever **PULL DOWN**
- 8 - Maintain attitude without rounding off until touch-down
- 9 - EVACUATE through EMERGENCY EXIT

3.3 - DEICING SYSTEM

WINDSHIELD MISTING OR INTERNAL ICING

Symptoms : - Mist or ice on windshield internal face

- 1 - "CABIN TEMP/°C" selector **Max HOT**
- 2 - "AIR FLOW" distributor **HOT**
- 3 - "L. WINDSHIELD" switch **ON**
- 4 - "R. WINDSHIELD" switch **ON**

If not successful, to gain sufficient visibility :

- 5 - Manually clean a sufficient visibility area
- 6 - If necessary, clean L.H. side window and conduct a sideslip approach (rudder pedals to the right) in order to get sufficient landing visual references
- 7 - Maintain IAS \geq 95 KIAS

CAUTION

IN CASE OF SIDESLIP APPROACH WITH PEDAL ON THE RIGHT DURING A LONG PERIOD, SELECT R.H. FUEL TANK

SECTION 4

NORMAL PROCEDURES

The normal procedures hereafter supplement or replace those of the TBM 700C1 airplane described in Section 4 "Normal procedures" of the TBM 700C1 Pilot's Operating Handbook, when using the TBM 700C2 airplane :

- between 6579 lbs (2984 kg) and 7394 lbs (3354 kg) for takeoff weight, and/or
- between 6250 lbs (2835 kg) and 7024 lbs (3186 kg) for landing weight.

4.1 - AIRSPEEDS FOR NORMAL OPERATION

CONDITIONS : - Takeoff weight : 7394 lbs (3354 kg)
 - Landing weight : 7024 lbs (3186 kg)

- 1 Rotation airspeed (V_R)
 - Flaps TO Depending on weight
 (See "Takeoff distances" Chapter 5.4
 of this Supplement)
- 2 Best rate of climb speed (V_Y)
 - Landing gear UP, flaps UP 124 KIAS
- 3 Best angle of climb speed (V_X) 100 KIAS
- 4 Maximum speed : Flaps TO 178 KIAS
 Flaps LDG 122 KIAS
- 5 Maximum speed with landing gear down 178 KIAS
- 6 Maximum landing gear operating speed
 - Extension 178 KIAS
 - Retraction 128 KIAS
- 7 Approach speed
 - Flaps LDG 85 KIAS
- 8 Maximum operating speed (V_{MO}) 266 KIAS
- 9 Glide speed (maximum L / D ratio)
 - Landing gear UP, flaps UP 120 KIAS
- 10 Maximum inertial separator operating speed 200 KIAS

4.2 - CHECK-LIST PROCEDURES

BEFORE STARTING ENGINE

CAUTION

"BLEED" SWITCH "ON" MAY CAUSE OVERTEMPERATURE OR ABNORMAL ACCELERATION AT START

CAUTION

MAKE SURE THAT "MAN OVRD" CONTROL IS "OFF" TO AVOID OVERTEMPERATURE RISKS AT START

- 1 - Preflight inspection **COMPLETED**
- 2 - Cabin access door **CLOSED / LOCKED**
- 3 - "Pilot" door (if installed) **CLOSED / LOCKED**
- 4 - Baggage **STOWED**
- 5 - Parking brake **SET**
- 6 - Weight and balance **COMPUTED / CHECKED**
- 7 - Pilot seat and R.H. front seat (if occupied)
 - Height adjustment **Maximum UP**
 - Fore and aft adjustment ... **ADJUST and CHECK LOCKING**
 - Height adjustment **ADJUST**
- 8 - R.H and L.H. pedals **ADJUSTED**
- 9 - Belts and harnesses (Pilot and passengers) **FASTENED**
- 10 - Oxygen supply **Available for the planned flight**
 (see tables in Chapter 4.3 "IN-FLIGHT AVAILABLE OXYGEN QUANTITY" paragraph, as well as Chapter 7.10 of the TBM 700C1 Pilot's Operating Handbook for a FAR 135 type operation)



CHECK-LIST PROCEDURES

BEFORE STARTING ENGINE (Cont'd)

- 11 - "OXYGEN" switch **ON**
- 12 - "PASSENGERS OXYGEN" switch **OFF**
- 13 - Copilot and pilot masks **Press push-button**
"PRESS TO TEST" : the blinker shall turn red
momentarily, then turns transparent
- 14 - "NORMAL/MASK" micro inverter **NORMAL**
- 15 - "IGNITION" switch **AUTO or OFF**
- 16 - "STARTER" switch **OFF**
- 17 - Landing gear control **DN**
- 18 - "RADIO MASTER" switch **ON**
- 19 - RADIO VHF1 **ON - ADJUSTED**
- 20 - Authorization for engine starting **ASKED**
- 21 - ETM
 - Fuel remaining **Check**
 - Added fuel **Insert**
 - Fuel flow page **Select**
- 22 - "SOURCE" selector **BAT (or GPU)**
- 23 - "BAT TEMP TEST" push-button
(Cadmium-Nickel battery, if installed) **PRESS**
- 24 - Passengers briefing **AS REQUIRED**
- 25 - Access door and
(if installed) "pilot" door **WARNING LIGHT**  **OFF**



CHECK-LIST PROCEDURES

BEFORE STARTING ENGINE (Cont'd)

- 26 - Fuel
 - Gages **CHECKED**
 - Tank selector **L or R - CHECKED**
 - "FUEL SEL" switch **AUTO**

WARNING LIGHT AUTO SEL OFF

- "SHIFT" push-button **PRESS**
The selector changes tank
On ground, observe a tank change
every minute and 15 seconds

27 - ETM fuel flowmeter totalizer **CHECKED - ADJUSTED**

28 - Engine instruments **CHECK**

29 - ITT TEST **CARRY OUT**

- 30 - EXT LIGHTS panel
 - "STROBE" **AS REQUIRED**

- 31 - In case of night flight
 - INT LIGHTS panel : "INSTR" + "PANEL" **ADJUSTED**
 - Navigation lights **ON**
 - Flashlight (if necessary) **IN PLACE**

INTENTIONALLY LEFT BLANK

CHECK-LIST PROCEDURES

TAKEOFF

WHEN LINED UP

CAUTION

- IF HEAVY PRECIPITATION, TURN IGNITION AND INERT SEP ON.
- IF ICING CONDITIONS ARE FORESEEN, REFER TO CHAPTER 4.4 OF THIS SUPPLEMENT, PARAGRAPH "FLIGHT INTO KNOWN ICING CONDITIONS"

- 1 - Heading - HSI - Stand-by compass **CHECK**
 - Altimeter setting **CHECK**

- 2 - Horizon **Attitude + 2° - CHECK**

- 3 - Lights
 - "L.LDG / TAXI / R.LDG" **ON**

- 4 - Engine instruments **CHECK**
(ITT = green sector)

- 5 - Advisory panel **CHECK**
All warning lights OFF,

except

INERT SEP

if used

except

IGNITION

if used

- 6 - Radar switch **As required**

7 - PROP O' SPEED GOVERNOR TEST

- Increase power until propeller RPM reaches 1900 RPM
- PROP O' SPEED **TEST : Maintain engaged**
- Observe that propeller RPM decreases by 50 to 250 RPM
- PROP O' SPEED **TEST : Release**
- Check that propeller RPM increases by a minimum of 50 RPM when compared to minimum value during PROP O'SPEED test.



CHECK-LIST PROCEDURES

TAKEOFF (Cont'd)

- 8 - Brakes **RELEASED**
- 9 - Power lever **TRQ = 100 %**
- 10 - Takeoff **ROTATION : See "Takeoff distances"
Chapter 5.4 of this Supplement**
- Attitude for normal takeoff **7°5**
 - Attitude for performance takeoff **12°5**
- 11 - Vertical speed indicator **POSITIVE**
- 12 - Brakes **APPLY
(Briefly)**
- 13 - Landing gear control (IAS < 128 KIAS) **UP
At sequence end, check : All warning lights OFF**
- 14 - Lights
- "TAXI" **OFF**
 - "L.LDG / R.LDG" **AS REQUIRED**
- 15 - Initial climb speed **115 KIAS**
- 16 - Flaps **UP**
- 17 - Climb speed (recommended) **130 KIAS**
- 18 - "YAW DAMPER" push-button **ON**

CHECK-LIST PROCEDURES

BEFORE LANDING

Long final

- 1 - Altimeters **CHECK**
- 2 - Fuel gages **CHECK / CORRECT**
 (Quantity / Symmetry)
 - Fullest tank **SELECT**
- 3 - "INERT SEP" switch (IAS ≤ 200 KIAS) **ON**
- 4 - Propeller lever **MAX RPM**
- 5 - Landing gear control (IAS ≤ 178 KIAS) **DN**
 - Green indicator lights **ON**
- 6 - Flaps (IAS ≤ 178 KIAS) **TO**
- 7 - Lights
 - "L.LDG / TAXI / R.LDG" **ON**
- 8 - Autopilot **OFF**
- 9 - Radar switch **SBY**

Short final

- 10 - Flaps (IAS ≤ 122 KIAS) **LDG**
- 11 - Approach speed (Flaps LDG) **85 KIAS**
- 12 - "YAW DAMPER" push-button **OFF**

CHECK-LIST PROCEDURES

GO-AROUND

- 1 - Simultaneously
 - Power lever **TRQ = 100 %**
 - Attitude **7°5**
- 2 - Flaps **TO**

If the vertical speed is positive and if IAS is at or above 90 kt :

- 3 - Landing gear control **UP**
All warning lights OFF

If IAS is at or above 115 kt :

- 4 - Flaps **UP**
- 5 - Climb speed **AS REQUIRED**

TOUCH AND GO

After wheel touch

- 1 - Flaps **TO**
- 2 - Elevator trim **Green sector**
- 3 - Power lever **Display TRQ = 100 %**
- 4 - Takeoff **ROTATION : See "Takeoff distances"**
Chapter 5.4 of this Supplement
ATTITUDE : 7°5

4.3 - AMPLIFIED PROCEDURES

BEFORE STARTING ENGINE

Check that the weight and balance are within the correct limits. Brief passengers about use of seat belts and the emergency oxygen system, as well as opening the access door and the emergency exit.

CAUTION

"BLEED" SWITCH "ON" MAY CAUSE OVERTEMPERATURE OR ABNORMAL ACCELERATION AT START

CAUTION

MAKE SURE THAT "MAN OVRD" CONTROL IS "OFF" TO AVOID OVERTEMPERATURE RISKS AT START

- 1 - Preflight inspection **COMPLETED**
- 2 - Cabin access door **CLOSED / LOCKED**
- 3 - "Pilot" door (if installed) **CLOSED / LOCKED**
- 4 - Baggage **STOWED**
- 5 - Parking brake **SET**
 "PARK BRAKE" warning light located on advisory panel does not indicate that parking brake is set. For that, press on brake pedals before turning parking brake selector to the right.
- 6 - Weight and balance **COMPUTED / CHECKED**



AMPLIFIED PROCEDURES

BEFORE STARTING ENGINE (Cont'd)

- 7 - Pilot seat and R.H. front seat (if occupied)
 - Height adjustment **Maximum UP**
 - Fore and aft adjustment . . . **ADJUST and CHECK LOCKING**
 - Height adjustment **ADJUST**

CAUTION

IT IS MANDATORY TO ADJUST SEAT IN FORE-AFT MOVEMENT WHEN SEAT IS IN MAXIMUM HIGH PERMISSIBLE POSITION, TO AVOID INTERFERENCE BETWEEN SIDE UPHOLSTERY PANEL AND SEAT HOUSING IN LOW AND INTERMEDIATE POSITIONS

Adjust pilot's and R.H. front station seats and harnesses, so as to permit access to all flight controls. The pilot at L.H. station must be able to easily reach ECS panel.

- 8 - R.H and L.H. pedals **ADJUSTED**
- 9 - Belts and harnesses (Pilot and passengers) **FASTENED**
Check belt buckles for correct locking, as well as automatic locking of shoulder harness by exerting a rapid pull on the latter.
- 10 - Oxygen supply **Available for the planned flight**
(see tables in Chapter 4.3 "IN-FLIGHT AVAILABLE OXYGEN QUANTITY" paragraph, as well as Chapter 7.10 of the TBM 700C1 Pilot's Operating Handbook for a FAR 135 type operation)
- 11 - "OXYGEN" switch **ON**
- 12 - "PASSENGERS OXYGEN" switch **OFF**
- 13 - Copilot and pilot masks **Press push-button "PRESS TO TEST" : the blinker shall turn red momentarily, then turns transparent**



AMPLIFIED PROCEDURES

BEFORE STARTING ENGINE (Cont'd)

- 14 - "NORMAL/MASK" micro inverter **NORMAL**
- 15 - "IGNITION" switch **AUTO or OFF**
The "IGNITION" switch is normally selected to AUTO. This ensures ignition, whenever the starter is activated.
- 16 - "STARTER" switch **OFF**
If not, starter is going to operate as soon as "SOURCE" selector is positioned on BAT or GPU in case of supplying by GPU.
- 17 - Landing gear control **DN**
- 18 - "RADIO MASTER" switch **ON**
- 19 - RADIO VHF1 **ON / ADJUSTED**
An electric relay automatically cuts off radio equipment during starter operation.
The function "GND CLR" (ground clearance) enables, when "RADIO MASTER" switch is ON, to obtain VHF1 supply without having selected battery contact.
- 20 - Authorization for engine starting **ASKED**
- 21 - ETM
 - Fuel remaining **Check**
 - Added fuel **Insert**
 - Fuel flow page **Select**
 The "SHADIN" ETM operation normal procedures are described in the Operation Manual, at the latest revision.
- 22 - "SOURCE" selector **BAT (or GPU)**
- 23 - "BAT TEMP TEST" push-button
(if installed - with a Cadmium-Nickel battery) **PRESS**
Check illumination of the "BAT OVHT" warning light on the advisory panel, check increase of the temperature indicated on the battery temperature indicator.
- 24 - Passengers briefing **AS REQUIRED**



AMPLIFIED PROCEDURES

BEFORE STARTING ENGINE (Cont'd)

25 - Access door and

(if installed) "pilot" door **WARNING LIGHT** **DOOR** **OFF**

If "DOOR" warning light is not OFF, open the access door and (if installed) the "pilot" door and reclose it (them). Check locking pins are in place (green band is visible). Do not take off with "DOOR" warning light ON on the advisory panel.

26 - Fuel

- Gages **CHECKED**
- Tank selector **L or R - CHECKED**
- "FUEL SEL" switch **AUTO**

WARNING LIGHT **AUTO SEL** **OFF**

- "SHIFT" push-button **PRESS**

**The selector changes tank
On ground, observe a tank change
every minute and 15 seconds**

27 - ETM fuel flowmeter totalizer **CHECKED - ADJUSTED**

Total fuel quantity on board may be set on flowmeter totalizer - see instruction in Section 7 of the TBM 700C1 Pilot's Operating Handbook or refer to manufacturer technical data.

28 - Engine instruments **CHECK**

29 - ITT TEST **CARRY OUT**

Check 1888 number appearance in digital readout window, as well as ITT red warning light illumination on advisory panel.

30 - EXT LIGHTS panel

- "STROBE" **AS REQUIRED**

The use of strobe lights may generate discomfort to personnel on ground, particularly by night.



AMPLIFIED PROCEDURES

BEFORE STARTING ENGINE (Cont'd)

31 - In case of night flight

- INT LIGHTS panel : "INSTR" + "PANEL" **ADJUSTED**
- Navigation lights **ON**
- Flashlight (if necessary) **IN PLACE**

To maintain battery power for starting, and only when "GND CLR" (ground clearance) is available on airplane, VHF1 can be operated by setting "SOURCE" selector to OFF and "RADIO MASTER" switch to ON. A correct operation is provided by the "GND CLR" green light illuminating above the "RADIO MASTER" switch. If battery voltage is low (near 25 volts), turn off all unessential electrical equipment before selecting the starter ON. By night, emergency lighting, provided by two luminous spot lights located above front seats, is sufficient to illuminate crew documents and instrument panel.

INTENTIONALLY LEFT BLANK

AMPLIFIED PROCEDURES

TAKEOFF

WHEN LINED UP

CAUTION

- IF HEAVY PRECIPITATION, TURN IGNITION AND INERT SEP ON.
- IF ICING CONDITIONS ARE FORESEEN, REFER TO CHAPTER 4.4 OF THIS SUPPLEMENT, PARAGRAPH "FLIGHT INTO KNOWN ICING CONDITIONS"

- 1 - Heading - HSI - Stand-by compass **CHECK**
The indication of the stand-by compass is disturbed when windshield(s) deice system(s) is (are) activated.
 - Altimeter setting **CHECK**
- 2 - Horizon **Attitude + 2° - CHECK**
Horizon has been set so as to indicate a 2° nose up attitude, when airplane center of gravity is at a middle average.
- 3 - Lights
 - "L.LDG / TAXI / R.LDG" **ON**
- 4 - Engine instruments **CHECK**
(ITT = green sector)
- 5 - Advisory panel **CHECK**

All warning lights OFF,

except

INERT SEP

if used

except

IGNITION

if used



AMPLIFIED PROCEDURES

TAKEOFF (Cont'd)

- 6 - Radar switch **As required**
- 7 - PROP O' SPEED GOVERNOR TEST
- Increase power until propeller RPM reaches 1900 RPM
 - PROP O' SPEED **TEST : Maintain engaged**
 - Observe that propeller RPM decreases by 50 to 250 RPM
 - PROP O' SPEED **TEST : Release**
 - Check that propeller RPM increases by a minimum of 50 RPM when compared to minimum value during PROP O'SPEED test.
- 8 - Brakes **RELEASED**
It is not necessary to reduce power at the end of "OVERSPEED" test ; torque will be about 40 % before brake release. For a normal takeoff, maximum torque (100 %) will be applied after brake release. On short runway, maximum torque will be applied before brake release.
- 9 - Power lever **TRQ = 100 %**
- 10 - Takeoff **ROTATION : See "Takeoff distances" Chapter 5.4 of this Supplement**
- Attitude for normal takeoff **7°5**
 - Attitude for performance takeoff **12°5**
- Rotation speed at takeoff, according to airplane weight, is also given in Chapter 5.4 of this Supplement.
- 11 - Vertical speed indicator **POSITIVE**
- 12 - Brakes **APPLY (Briefly)**



AMPLIFIED PROCEDURES

TAKEOFF (Cont'd)

13 - Landing gear control (IAS < 128 KIAS) **UP**

During the sequence :

- The red warning light flashes ; it indicates that the landing gear motor is electrically supplied. It goes off when the 3 landing gears are locked. If the red warning light is fixed ON, there is a discrepancy (refer to EMERGENCY PROCEDURES).
- It is possible that the 3 landing gear position green indicator lights flash uncertainly then go off at the end of the sequence.

At sequence end, check : All warning lights OFF

In practice, if preconized attitude is kept, there is no difficulty to maintain a speed < 128 KIAS until landing gear retraction is completed.

14 - Lights

- "TAXI" **OFF**
- "L.LDG / R.LDG" **AS REQUIRED**

15 - Initial climb speed **115 KIAS**

16 - Flaps **UP**

17 - Climb speed (recommended) **130 KIAS**

18 - "YAW DAMPER" push-button **ON**

AMPLIFIED PROCEDURES

CLIMB

- 1 - Power lever **ADJUST according to engine operation table - Chapter 5.7 of the TBM 700C1 Pilot's Operating Handbook**

CAUTION

**OBSERVE TRQ / Ng / Np / ITT / T°
AND OIL PRESSURE LIMITATIONS
(Refer to tables in Chapter 5.7 of the
TBM 700C1 Pilot's Operating Handbook)**

Torque setting during climb must be adjusted according to engine operation tables in Chapter 5.7 of the TBM 700C1 Pilot's Operating Handbook. These tables give the max. climb power torque setting (MXCL). For each engine, when torque is reduced below 100 % at high altitude according to the tables, the ITT will be approximately constant during final climb, giving a particular value of ITT. For a simplified engine operation during climb, power may be set first of all by torque, using 100 %, then, when the ITT typical value for climb is reached, by indicated ITT, using this particular value. The margin between this indicated ITT and 785°C (recommended ITT limit during continuous operation) will gradually reduce as flight time is performed.

- 2 - Climb speed **AS REQUIRED**
Best climb speed is 124 KIAS. Performance tables concerning climb at 130 and 160 KIAS are given in Chapter 5.5 of this Supplement.



AMPLIFIED PROCEDURES

CLIMB (Cont'd)

- 3 - ECS panel
 - Cabin altitude selector **Cruise altitude + 1000 feet**
 - Cabin rate selector **ADJUST so as to obtain a cabin climb rate of about 500 ft/min**

It concerns the control on triple indicator of cabin rate, as well as increasing of differential pressure and cabin altitude.

- Pressurization **CHECK**
- "CABIN TEMP/° C" selector **ADJUST**
Anticipate setting to hot position during climb. Do not wait a fresh sensation to perform this setting. Desired temperature will be as longer to obtain as setting is made later.
- 4 - Fuel tank gages **CHECK / CORRECT (Quantity / Symmetry)**

Pre-MOD70-0402-28

In spite of fuel selector automatic operation, a non-negligible dissymmetry may be observed at the end of climb, for example when 10 minutes of climb have been performed on the same fuel tank. Tolerated maximum dissymmetry is 25 us gal (95 Litres).

- 5 - DE ICE SYSTEM **As required**
Refer to Chapter 4.5 "PARTICULAR PROCEDURES" of the TBM 700C1 Pilot's Operating Handbook For "Flight into known icing conditions", refer to Chapter 4.4 of this Supplement

<p>CAUTION</p> <p>IF HEAVY PRECIPITATION, TURN IGNITION AND INERT SEP ON</p>
--

AMPLIFIED PROCEDURES

BEFORE LANDING

Long final

- 1 - Altimeters **CHECK**
- 2 - Fuel gages **CHECK / CORRECT**
(Quantity / Symmetry)
- Fullest tank **SELECT**

Maximum tolerated dissymmetry is 25 us gal (95 Litres).

- 3 - "INERT SEP" switch (IAS ≤ 200 KIAS) **ON**
- 4 - Propeller lever **MAX RPM**
- 5 - Landing gear control (IAS ≤ 178 KIAS) **DN**

During the sequence :

- The red warning light flashes ; it indicates that the landing gear motor is electrically supplied. It goes off when the 3 landing gears are locked. If the red warning light is fixed ON, there is a discrepancy (refer to EMERGENCY PROCEDURES of the TBM 700C1 Pilot's Operating Handbook).
- It is possible that the 3 landing gear position green indicator lights flash uncertainly then come on at the end of the sequence, indicating that the landing gears are locked in down position.
- Green indicator lights **ON**

- 6 - Flaps (IAS ≤ 178 KIAS) **TO**
- 7 - Lights
- "L.LDG / TAXI / R.LDG" **ON**



AMPLIFIED PROCEDURES

BEFORE LANDING (Cont'd)

8 - Autopilot **OFF**
 Autopilot must be disconnected at the latest at 200 ft above the ground or at decision height or before go-around, whichever is the highest.

9 - Radar switch **SBY**

Short final

10 - Flaps (IAS \leq 122 KIAS) **LDG**
 However, when autopilot is engaged, in APR mode, with coupled GS, flaps must be extended in landing position before crossing the OUTER MARKER.

11 - Approach speed (Flaps LDG) **85 KIAS**
 To ensure positive and rapid engine response to throttle movement, it is recommended that a minimum of 10 % torque be maintained on final approach until landing is assured.

<p>12 - "YAW DAMPER" push-button OFF The pilot effort required to use the rudder pedals is reduced if the yaw damper is turned off. This is particularly significant when landing in a crosswind.</p>

AMPLIFIED PROCEDURES

GO-AROUND

- 1 - Simultaneously
- Power lever **TRQ = 100 %**
 - Attitude **7°5**

The airplane will tend to yaw to the left when power is applied. A considerable right rudder pressure will be required to maintain coordinated straight flight until the rudder trim can be adjusted to TO sector.

- 2 - Flaps **TO**
- If speed has been maintained at 85 KIAS or more and TRQ 100 %, select TO flaps as soon as the 7°5 attitude has been attained.

If the vertical speed is positive and if IAS is at or above 90 KIAS :

- 3 - Landing gear control **UP**
All warning lights OFF

If IAS is at or above 115 KIAS :

- 4 - Flaps **UP**
- 5 - Climb speed **AS REQUIRED**

AMPLIFIED PROCEDURES

TOUCH AND GO

After wheel touch

- 1 - Flaps **TO**

Check that flaps have well reached the TO position before increasing power. Do not increase power with full flaps, as airplane may lift off prematurely at low speed.

- 2 - Elevator trim **Green sector**

To use elevator trim manual control is faster than to use electric control. Ensure that runway length is sufficient to complete this sequence.

- 3 - Power lever **Display TRQ = 100 %**

- 4 - Takeoff **ROTATION : See "Takeoff distances"
Chapter 5.4 of this Supplement
ATTITUDE : 7°5**

However, the pilot's operating handbook does not supply distances concerning touch and go. These distances are let to pilot's initiative.

4.4 - PARTICULAR PROCEDURES

REMARK :

The procedures and procedure elements given in this Chapter "PARTICULAR PROCEDURES" supplement the normal procedures.

FLIGHT INTO KNOWN ICING CONDITIONS**General**

- 1 - Icing conditions exist when the IOAT on the ground or in flight is + 13°C or below, and visible moisture in any form is present (clouds, fog with visibility of one mile (1.6 km) or less, rain, snow, sleet or ice crystals).
- 2 - Icing conditions also exist when the IOAT on the ground is + 13°C or below and when operating on ramps, taxiways or runways where surface snow, ice, standing water or slush may be ingested by the engine or freeze on engine or cowlings.

NOTE :

Refer to Figure 5.4.1 of the TBM 700C1 Pilot's Operating Handbook to convert IOAT to SAT in flight.

SAT = IOAT - 2°C on the ground.

- 3 - Flight into known icing conditions is authorized when all airplane equipment provided for ice protection is operating correctly. This includes :
 - Pneumatic deice system for inboard and outboard wing, for stabilizers and for elevator horns.
 - Propeller electrical deice system.
 - Electrical heating system for both pitots and for the stall warning incidence sensor.
 - Windshield electrical deice system.
 - Inertial separator.

Description of deice systems is presented in Chapter 7.13 of the TBM 700C1 Pilot's Operating Handbook.

Ice accumulation thickness is monitored by the pilot on the L.H. wing leading edge.

At night, a leading edge icing inspection light located on the fuselage L.H. side, activated by the "ICE LIGHT" switch, is provided.

PARTICULAR PROCEDURES

FLIGHT INTO KNOWN ICING CONDITIONS (Cont'd)

Boots are automatically cycling at the optimum time to assure proper ice removal. Correct operation of the system can be checked observing the corresponding green advisory light illumination at each boot inflation impulse. If correct operation cannot be confirmed, do not enter or leave as soon as possible icing conditions.

Apply "LEADING EDGES DEICING FAILURE" emergency procedure of the TBM 700C1 Pilot's Operating Handbook.

Ice protection procedures

- 1 - Prior to entering IMC, as a preventive :

If IOAT ≤ 13° C :

- "INERT SEP" switch **ON**
- "IGNITION" switch **ON**
- "PROP DE ICE" switch **ON**
- "AIRFRAME DE ICE" switch **ON**
- "WINDSHIELD DE ICE" switch **ON**

- 2 - When operating under IMC :

- "INERT SEP" switch **ON**
- "IGNITION" switch **ON**
- "PROP DE ICE" switch **ON**
- "AIRFRAME DE ICE" switch **ON**
- "WINDSHIELD DE ICE" switch **ON**

NOTE :

When IOAT is below - 25° C, avoid operations of the "AIRFRAME DEICE SYSTEM" for a too long period because the boots could be damaged. The "INERT SEP" switch must be left ON while the airplane remains in icing conditions.

PARTICULAR PROCEDURES

FLIGHT INTO KNOWN ICING CONDITIONS (Cont'd)

- 2 - When operating under IMC :
- All "DE ICE SYSTEM" switches **ON**
 - "IGNITION" switch **ON**
 - "INERT SEP" switch **ON**

CAUTION

**SHOULD CONDITIONS REQUIRE IT, APPLY THESE DIRECTIVES
FROM BEGINNING OF TAXI ONWARDS**

**DO NOT OPERATE THE INERTIAL SEPARATOR IF THE AIRSPEED
EXCEEDS 200 KIAS. THERE IS NO SPEED LIMITATION WHEN
THE INERTIAL SEPARATOR IS IN FIXED POSITION**

If a high speed descent (> 200 KIAS) is anticipated into known icing conditions, position "INERT SEP" switch to ON before accelerating. This will avoid reducing speed below 200 KIAS during descent to set the inertial separator.

**IF AIRPLANE LEAVES ICING CONDITIONS, MAINTAIN "INERT SEP" ON
AS LONG AS ICE THICKNESS ON NON-DEICED VISIBLE PARTS
EXCEEDS 15 mm (OR ½ INCH)**

This will avoid ice fragments coming from propeller spinner and being ingested by engine.

**INERTIAL SEPARATOR POSITION AFFECTS ENGINE PARAMETERS
(PARTICULARLY TRQ AND ITT). CARE MUST BE EXERCISED WHEN
OPERATING THE INERTIAL SEPARATOR OR WHEN INCREASING
POWER WITH THE INERTIAL SEPARATOR ON, TO AVOID EXCEEDING
ENGINE LIMITATIONS**

PARTICULAR PROCEDURES

FLIGHT INTO KNOWN ICING CONDITIONS (Cont'd)

NOTE :

"IGNITION" switch may be left ON for a long period.

Standby compass indications are altered when windshield deicing system(s) operate(s).

3 - Procedures for holding, approach and landing in icing conditions :

- Minimum recommended speeds are :

- . Flaps UP 135 KIAS
- . Flaps TO 115 KIAS
- . Flaps LDG 95 KIAS

- If there is ice on the unprotected surfaces of the airplane, during flight end phase, conduct holding with the flaps up. Use flaps as required for final approach and landing at minimum speeds noted above.

PARTICULAR PROCEDURES

FLIGHT INTO KNOWN ICING CONDITIONS (Cont'd)

Ice accumulation effects

When ice has accumulated on the unprotected surfaces of the airplane, aerodynamic characteristics may be changed.

Particularly stall speeds may increase by up to :

- Flaps UP 20 KIAS
- Flaps TO 15 KIAS
- Flaps LDG 10 KIAS

Correct operation of the aural stall warning may be altered by severe or prolonged icing.

Indeed, in case of severe or prolonged icing, an ice concretion due to refreezing around the heated stall warning may appear. Above-recommended speeds take into account, on one side, the stall speed increase due to profile shape deterioration and, on the other side, the weight increase of the iced-up airplane (taking as a basis the airplane maximum weight when not iced-up).

Rate of climb values with ice accumulation on the unprotected surfaces are to be decreased by 10 %.

Cruise speeds may be decreased by 10 %, if cruise power is not changed, or more, if cruise power setting should be decreased due to the additional inertial separator limitations (ITT limitation).

Because of the higher landing speed, landing distances will be increased. In the landing configuration, using 90 KIAS approach speed increases landing distance by 20 % - refer to Chapter 5.7 "LANDING DISTANCES" of this Supplement.

SECTION 5
PERFORMANCE
TABLE OF CONTENTS

	Page
5.1 - ACOUSTIC LIMITATION	9.41.32
5.2 - STALL SPEEDS	9.41.33
Fig. 9.41.2 - STALL SPEEDS	9.41.33
5.3 - Demonstrated crosswind	9.41.33
5.4 - TAKEOFF DISTANCES	9.41.34
Fig. 9.41.3 : WEIGHT : 7394 lbs (3354 kg)	9.41.34
5.5 - CLIMB PERFORMANCE [7394 Lbs (3354 Kg)]	9.41.35
Fig. 9.41.4 : CLIMB SPEEDS (IAS = 130/160 KIAS)	9.41.35
TIME, CONSUMPTION AND CLIMB DISTANCE [7394 Lbs (3354 Kg)]	9.41.36
Fig. 9.41.5 : Conditions : ISA - 20°C	9.41.36
Fig. 9.41.6 : Conditions : ISA	9.41.37
Fig. 9.41.7 : Conditions : ISA + 20°C	9.41.38
Fig. 9.41.8 : CLIMB PERFORMANCE AFTER GO-AROUND	9.41.39
Fig. 9.41.9 : CLIMB PERFORMANCE - FLAPS TO	9.41.39
5.6 - CRUISE PERFORMANCE	9.41.40
Maximum cruise	9.41.40
Fig. 9.41.10 : Conditions : ISA - 20°C	9.41.40
Fig. 9.41.11 : Conditions : ISA - 10°C	9.41.41
Fig. 9.41.12 : Conditions : ISA - 5°C	9.41.42
Fig. 9.41.13 : Conditions : ISA	9.41.43
Fig. 9.41.14 : Conditions : ISA + 5°C	9.41.44
Fig. 9.41.15 : Conditions : ISA + 10°C	9.41.45
Fig. 9.41.16 : Conditions : ISA + 20°C	9.41.46
Normal (recommended) cruise	9.41.47
Fig. 9.41.17 : Conditions : ISA - 20°C	9.41.47
Fig. 9.41.18 : Conditions : ISA - 10°C	9.41.48
Fig. 9.41.19 : Conditions : ISA - 5°C	9.41.49
Fig. 9.41.20 : Conditions : ISA	9.41.50
Fig. 9.41.21 : Conditions : ISA + 5°C	9.41.51
Fig. 9.41.22 : Conditions : ISA + 10°C	9.41.52
Fig. 9.41.23 : Conditions : ISA + 20°C	9.41.53

TABLE OF CONTENTS (Cont'd)

	Page
Intermediate cruise	9.41.54
Fig. 9.41.24 : Conditions : ISA - 20°C	9.41.54
Fig. 9.41.25 : Conditions : ISA - 10°C	9.41.55
Fig. 9.41.26 : Conditions : ISA - 5°C	9.41.56
Fig. 9.41.27 : Conditions : ISA	9.41.57
Fig. 9.41.28 : Conditions : ISA +5°C	9.41.58
Fig. 9.41.29 : Conditions : ISA + 10°C	9.41.59
Fig. 9.41.30 : Conditions : ISA + 20°C	9.41.60
Long Range Cruise (6614 lbs - 3000 kg)	9.41.61
Fig. 9.41.31 (1/2) : Altitude \leq 24000 ft	9.41.61
Fig. 9.41.31 (2/2) : Altitude \geq 24000 ft	9.41.62
Long Range Cruise (7275 lbs - 3300 kg)	9.41.63
Fig. 9.41.32 (1/2) : Altitude \leq 24000 ft	9.41.63
Fig. 9.41.32 (2/2) : Altitude \geq 24000 ft	9.41.64
5.7 - LANDING DISTANCES	9.41.65
Fig. 9.41.33 : WEIGHT : 7024 lbs (3186 kg)	9.41.65

Information hereafter supplement or replace those of the TBM 700C1 airplane described in Section 5 "Performance" of the TBM 700C1 Pilot's Operating Handbook when using the TBM 700C2 airplane :

- between 6579 lbs (2984 kg) and 7394 lbs (3354 kg) for takeoff weight, and/or
- between 6250 lbs (2835 kg) and 7024 lbs (3186 kg) for landing weight.

5.1 - ACOUSTIC LIMITATION

	Maximum noise level permissible	Demonstrated noise level
FAR PART 36, Appendix G - Amendment 22 / OACI, Annex 16, Chapter 10, Appendix 6	88 dB(A)	79.6 dB(A)

TBM 700 airplane has received the noise limitation type certificate Nr N181 dated 31st January 1990, as well as Type Certificate Data Sheet EASA.A.010 dated 14 July 2004.

5.2 - STALL SPEEDS

AIR- PLANE WEIGHT	CONFIG.		BANK											
	FLIGHT IDLE		0°			30°			45°			60°		
	LDG GR	Flaps	KIAS	KCAS	MPH IAS	KIAS	KCAS	MPH IAS	KIAS	KCAS	MPH IAS	KIAS	KCAS	MPH IAS
7394 lbs (3354 kg)	UP	UP	81	83	93	88	89	101	97	99	112	119	117	137
	DN	TO	77	77	89	81	83	93	91	92	105	108	109	124
	DN	LDG	65	65	75	69	70	79	76	77	88	92	92	106

Figure 9.41.2 - STALL SPEEDS

5.3 - DEMONSTRATED CROSSWIND

20 kts

5.4 - TAKEOFF DISTANCES

WEIGHT : 7394 lbs (3354 kg)

- Associated conditions :
- Landing gear DN and flaps TO
 - 12°5 of attitude - TRQ = 100 %
 - Np = 2000 RPM - BLEED ON
 - Hard, dry and level runway
 - GR = Ground roll (in ft)
 - D₅₀ = Takeoff distance (clear to 50 ft) (in ft)
 - Rotation speed choice (V_R)

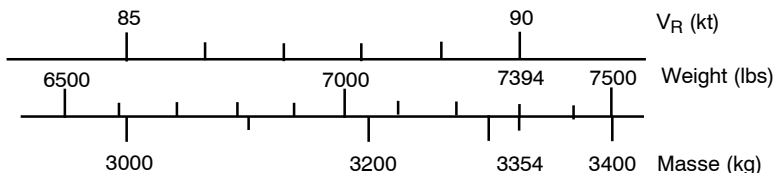

WEIGHT : 7394 lbs (3354 kg) At 50 ft = 99 KIAS - 114 MPH IAS								
PRESSURE ALTITUDE ft	ISA - 35°C		ISA - 20°C		ISA - 10°C		ISA	
	GR	D50	GR	D50	GR	D50	GR	D50
0	1575	2250	1755	2495	1905	2675	2035	2840
2000	1755	2495	1970	2755	2120	2955	2280	3150
4000	1970	2755	2200	3055	2380	3285	2545	3510
6000	2185	3035	2480	3415	2675	3675	2890	3955
8000	2460	3380	2790	3825	3055	4135	3315	4445
PRESSURE ALTITUDE ft	ISA + 10°C		ISA + 20°C		ISA + 30°C		ISA + 37°C	
	GR	D50	GR	D50	GR	D50	GR	D50
0	2165	3020	2315	3200	2480	3415	2560	3530
2000	2445	3365	2595	3580	2780	3805	2920	3990
4000	2740	3760	2955	4035	3185	4300	3330	4480
6000	3135	4235	3380	4530	3625	4825	3805	5055
8000	3560	4760	3855	5105	4170	5450	4380	5710

Figure 9.41.3 - TAKEOFF DISTANCES - 7394 lbs (3354 kg)

- Corrections :
- . Reduce total distances of 10 % every 10 kts of headwind
 - . Increase total distances of 30 % every 10 kts of tail wind
 - . Increase by :

7 %	on hard sod	25 %	on high grass
10 %	on short grass	30 %	on slippery runway
15 %	on wet runway		

NOTE :

Between ISA + 30°C and ISA + 37°C, it may be necessary to cut-off the Bleed in order to set

5.5 - CLIMB PERFORMANCE [7394 Lbs (3354 Kg)]

CLIMB SPEEDS (IAS = 130/160 KIAS)

Conditions : Maximum climb power
 Landing gear and flaps UP
 BLEED ON

IAS (KIAS)	Pressure altitude (feet)	RATE OF CLIMB (ft/min)					
		ISA - 20°C	ISA - 10°C	ISA	ISA + 10°C	ISA + 20°C	ISA + 30°C
130	SL	1725	1645	1570	1500	1435	1380
	2000	1700	1615	1540	1470	1405	1345
	4000	1670	1590	1510	1440	1375	1315
	6000	1640	1555	1480	1410	1340	1280
	8000	1610	1525	1445	1375	1310	1250
160	SL	1540	1460	1390	1320	1255	1200
	2000	1510	1430	1355	1285	1225	1165
	4000	1470	1390	1315	1245	1185	1125
	6000	1430	1350	1275	1205	1140	1080
	8000	1395	1315	1240	1170	1105	1035

Figure 9.41.4 - CLIMB SPEEDS (IAS = 130/160 KIAS)

CLIMB PERFORMANCE

TIME, CONSUMPTION AND CLIMB DISTANCE [7394 Lbs (3354 Kg)]

Conditions : **ISA - 20°C**
 Maximum climb power
 Landing gear and flaps UP
 2000 RPM - BLEED ON

NOTE :
Time, consumption and distance from the 50 ft

Pressure altitude (feet)	130 KIAS					160 KIAS up to 20000 ft then - 2 KIAS/1000 ft				
	Time (min. s)	Consump.			Dist. (NM)	Time (min. s)	Consump.			Dist. (NM)
		l	kg	us gal			l	kg	us gal	
SL	00.00	0	0	0	0	00.00	0	0	0	0
2000	01.10	6	5	2	2	01.20	7	5	2	3
4000	02.25	11	9	3	5	02.40	13	10	3	7
6000	03.35	17	13	4	8	04.00	19	15	5	11
8000	04.50	22	18	6	11	05.25	25	20	7	15
10000	06.00	28	22	7	13	06.55	32	25	8	19
12000	07.20	33	26	9	17	08.25	38	30	10	23
14000	08.35	38	30	10	20	09.55	44	34	12	28
16000	09.55	43	34	11	23	11.30	50	39	13	33
18000	11.20	48	38	13	27	13.05	56	44	15	38
20000	12.40	54	42	14	31	14.55	63	49	17	45
22000	14.05	59	46	16	35	16.35	69	54	18	51
24000	15.35	64	50	17	39	18.20	75	59	20	56
26000	17.05	70	55	18	44	20.00	81	64	21	62
28000	18.40	75	59	20	49	21.40	87	68	23	68
30000	20.30	81	64	21	55	23.30	93	73	25	75
31000	21.27	85	66	22	58	24.38	97	76	26	79

Figure 9.41.5 - TIME, CONSUMPTION AND CLIMB DISTANCE (IAS = 130/160 KIAS)/ISA - 20°C

CLIMB PERFORMANCE

TIME, CONSUMPTION AND CLIMB DISTANCE [7394 Lbs (3354 Kg)]

Conditions : **ISA**

Maximum climb power

Landing gear and flaps UP

2000 RPM - BLEED ON

NOTE :

Time, consumption and distance from the 50 ft

Pressure altitude (feet)	130 KIAS					160 KIAS up to 20000 ft then - 2 KIAS/1000 ft				
	Time (min. s)	Consump.			Dist. (NM)	Time (min. s)	Consump.			Dist. (NM)
		l	kg	us gal			l	kg	us gal	
SL	00.00	0	0	0	0	00.00	0	0	0	0
2000	01.20	7	5	2	3	01.30	7	6	2	4
4000	02.35	13	10	3	6	03.00	15	12	4	8
6000	03.50	19	15	5	9	04.30	22	17	6	12
8000	05.20	25	20	7	12	06.05	29	23	8	17
10000	06.40	31	25	8	15	07.40	36	28	10	22
12000	08.05	37	29	10	19	09.25	43	34	11	27
14000	09.30	43	34	11	23	11.05	50	40	13	33
16000	11.00	49	39	13	27	13.00	58	45	15	39
18000	12.30	55	43	15	31	14.55	65	51	17	46
20000	14.05	61	48	16	36	16.55	73	57	19	53
22000	15.50	67	53	18	41	18.55	80	63	21	60
24000	17.30	74	58	19	46	20.55	87	69	23	67
26000	19.35	81	63	21	53	23.10	95	75	25	76
28000	22.10	89	70	23	62	26.10	105	82	28	87
30000	25.35	99	78	26	73	30.00	116	91	31	101
31000	27.51	105	82	28	81	32.44	124	97	33	111

Figure 9.41.6 - TIME, CONSUMPTION AND CLIMB DISTANCE (IAS = 130/160 KIAS)/ISA

CLIMB PERFORMANCE

TIME, CONSUMPTION AND CLIMB DISTANCE [7394 Lbs (3354 Kg)]

Conditions : **ISA + 20°C**
 Maximum climb power
 Landing gear and flaps UP
 2000 RPM - BLEED ON

NOTE :
Time, consumption and distance from the 50 ft

Pressure altitude (feet)	130 KIAS					160 KIAS up to 20000 ft then - 2 KIAS/1000 ft				
	Time (min. s)	Consump.			Dist. (NM)	Time (min. s)	Consump.			Dist. (NM)
		l	kg	us gal			l	kg	us gal	
SL	00.00	0	0	0	0	00.00	0	0	0	0
2000	01.25	7	6	2	3	01.35	8	7	2	5
4000	02.50	15	11	4	7	03.20	17	13	4	9
6000	04.20	22	17	6	10	05.00	25	20	7	14
8000	05.50	28	22	8	14	06.40	33	26	9	20
10000	07.20	35	28	9	18	08.35	41	32	11	25
12000	08.55	42	33	11	22	10.30	49	39	13	32
14000	10.30	49	38	13	26	12.30	58	45	15	38
16000	12.10	56	44	15	31	14.35	66	52	17	46
18000	14.00	63	49	17	36	17.00	75	59	20	54
20000	16.10	70	55	19	43	19.55	86	68	23	65
22000	18.40	79	62	21	51	23.30	98	77	26	79
24000	21.55	89	70	24	61	27.55	113	88	30	95
26000	26.00	101	80	27	75	33.55	130	102	34	118
28000	32.20	118	93	31	96	43.50	157	124	42	156
30000	44.55	151	118	40	142	68.10	220	172	58	250
31000	68.51	208	163	55	230	/	/	/	/	/

Figure 9.41.7 - TIME, CONSUMPTION AND CLIMB DISTANCE (IAS = 130/160 KIAS)/ISA + 20°C

CLIMB PERFORMANCE

CLIMB PERFORMANCE AFTER GO-AROUND

Conditions : Maximum climb power
 Landing gear DN and flaps LDG
 IAS = 95 KIAS

Airplane weight	Pressure altitude (feet)	RATE OF CLIMB (ft/min)						
		ISA - 35°C	ISA - 20°C	ISA - 10°C	ISA	ISA + 10°C	ISA + 20°C	ISA + 30°C
7394 lbs (3354 kg)	SL	1120	1025	960	905	850	805	760
	2000	1085	985	920	865	810	765	715
	4000	1045	945	880	825	770	720	675
	6000	1010	905	840	780	730	680	630
	8000	965	860	795	740	685	630	580

Figure 9.41.8 - CLIMB PERFORMANCE AFTER GO-AROUND

CLIMB PERFORMANCE - FLAPS TO

Conditions : Climb maximum power
 Landing gear UP and flaps TO
 IAS = 115 KIAS

Airplane weight	Pressure altitude (feet)	RATE OF CLIMB (ft/min)						
		ISA - 35°C	ISA - 20°C	ISA - 10°C	ISA	ISA + 10°C	ISA + 20°C	ISA + 30°C
7394 lbs (3354 kg)	SL	1825	1695	1615	1545	1475	1415	1355
	2000	1800	1670	1590	1515	1450	1390	1325
	4000	1775	1640	1560	1490	1420	1360	1300
	6000	1750	1620	1540	1465	1395	1330	1270
	8000	1720	1585	1505	1430	1360	1295	1230

Figure 9.41.9 - CLIMB PERFORMANCE - FLAPS TO

5.6 - CRUISE PERFORMANCE**Maximum cruise**

Conditions : **ISA - 20°C**
 Landing gear and flaps UP
 2000 RPM (*) - BLEED ON

NOTE :

Use preferably recommended cruise power

Pressure altitude (feet)	IOAT (°C)	TRQ (%)	Fuel flow			AIRSPEEDS (kt)			
						6614 lbs (3000 kg)		7275 lbs (3300 kg)	
			l / h	kg / h	us gal / h	IAS	TAS	IAS	TAS
0	+ 2	100	304	239	80.3	228	223	227	222
5000	- 8	100	275	216	72.6	223	234	221	232
10000	- 17	100	250	196	66.0	218	245	216	244
15000	- 26	100	232	182	61.2	212	258	210	256
18000	- 32	100	223	175	58.9	208	266	206	263
20000	- 36	100	218	171	57.6	206	271	204	269
21000	- 37	100	216	170	57.1	205	274	203	271
22000	- 39	100	214	168	56.5	204	277	202	274
23000	- 41	100	212	166	56.0	203	280	200	278
24000	- 43	100	210	165	55.6	202	283	200	280
25000	- 45	100	209	164	55.3	201	286	198	283
26000	- 46	100	208	163	54.9	200	289	197	286
27000	- 48	100	207	162	54.7	198	292	196	289
28000	- 50	100	206	162	54.4	197	295	195	292
29000	- 52	100	206	161	54.3	196	299	194	295
30000	- 54	100	205	161	54.2	195	302	193	298
31000	- 56	100	206	161	54.3	194	306	191	301

Figure 9.41.10 - CRUISE PERFORMANCE -
 Maximum cruise / ISA - 20°C

(*) Propeller RPM utilization between 1600 and 2000 RPM is possible without changing performance. Display the TRQ indicated in table with Np = 2000 RPM, then reduce Np without resetting power lever (within limits permitted by torque limiter).

CRUISE PERFORMANCE

Maximum cruise

Conditions : **ISA - 10°C**
 Landing gear and flaps UP
 2000 RPM (*) - BLEED ON

NOTE :
 Use preferably recommended cruise power

Pressure altitude (feet)	IOAT (°C)	TRQ (%)	Fuel flow			AIRSPEEDS (kt)			
						6614 lbs (3000 kg)		7275 lbs (3300 kg)	
			l / h	kg / h	^{us} gal / h	IAS	TAS	IAS	TAS
0	+ 12	100	308	242	81.4	227	226	225	224
5000	+ 2	100	279	219	73.6	221	236	220	235
10000	- 7	100	254	199	67.0	216	248	214	247
15000	- 16	100	234	184	61.9	210	261	208	258
18000	- 22	100	225	177	59.4	207	269	204	266
20000	- 25	100	220	173	58.2	204	274	202	272
21000	- 27	100	218	171	57.6	203	277	201	275
22000	- 29	100	216	170	57.1	202	280	200	277
23000	- 31	100	215	168	56.7	201	283	198	281
24000	- 33	100	213	167	56.3	199	286	197	283
25000	- 34	100	212	166	55.9	198	289	196	286
26000	- 36	100	210	165	55.6	197	292	195	289
27000	- 38	100	209	164	55.3	196	296	194	292
28000	- 40	100	209	164	55.2	195	299	192	295
29000	- 42	97	201	158	53.2	191	297	188	292
30000	- 44	93	194	152	51.2	186	295	183	290
31000	- 46	91	187	146	49.3	182	293	178	287

Figure 9.41.11 - CRUISE PERFORMANCE -
 Maximum cruise / ISA - 10°C

(*) Propeller RPM utilization between 1600 and 2000 RPM is possible without changing performance. Display the TRQ indicated in table with Np = 2000 RPM, then reduce Np without resetting power lever (within limits permitted by torque limiter).

CRUISE PERFORMANCE

Maximum cruiseConditions : **ISA - 5°C**

Landing gear and flaps UP

2000 RPM (*) - BLEED ON

NOTE :*Use preferably recommended cruise power*

Pressure altitude (feet)	IOAT (°C)	TRQ (%)	Fuel flow			AIRSPEEDS (kt)			
						6614 lbs (3000 kg)		7275 lbs (3300 kg)	
			l / h	kg / h	^{us} gal / h	IAS	TAS	IAS	TAS
0	+ 17	100	310	243	81.8	226	227	224	225
5000	+ 8	100	280	220	74.1	220	238	219	236
10000	- 2	100	255	200	67.4	215	250	213	248
15000	- 11	100	235	185	62.2	209	262	207	260
18000	- 17	100	226	178	59.8	206	270	203	268
20000	- 20	100	222	174	58.6	203	276	201	273
21000	- 22	100	220	173	58.1	202	279	200	276
22000	- 24	100	218	171	57.5	201	282	199	279
23000	- 26	100	216	170	57.1	200	285	197	283
24000	- 28	100	215	168	56.7	199	288	196	285
25000	- 29	100	213	167	56.3	198	291	195	288
26000	- 31	100	212	166	56.0	196	294	194	291
27000	- 33	99	210	165	55.5	194	296	192	292
28000	- 35	96	202	159	53.5	190	294	187	290
29000	- 37	92	195	153	51.5	185	292	182	287
30000	- 39	88	188	147	49.6	181	290	177	285
31000	- 41	86	181	142	47.7	177	288	172	281

Figure 9.41.12 - CRUISE PERFORMANCE -
Maximum cruise / ISA - 5°C

(*) Propeller RPM utilization between 1600 and 2000 RPM is possible without changing performance. Display the TRQ indicated in table with Np = 2000 RPM, then reduce Np without resetting power lever (within limits permitted by torque limiter).

CRUISE PERFORMANCE

Maximum cruise

Conditions : **ISA**
 Landing gear and flaps UP
 2000 RPM (*) - BLEED ON

NOTE :
 Use preferably recommended cruise power

Pressure altitude (feet)	IOAT (°C)	TRQ (%)	Fuel flow			AIRSPEEDS (kt)			
						6614 lbs (3000 kg)		7275 lbs (3300 kg)	
			l / h	kg / h	us gal / h	IAS	TAS	IAS	TAS
0	+ 22	100	312	245	82.3	225	228	223	227
5000	+ 13	100	282	221	74.5	220	239	218	238
10000	+ 3	100	257	201	67.8	214	251	212	249
15000	- 6	100	237	186	62.5	208	264	206	261
18000	- 12	100	228	179	60.2	205	272	203	269
20000	- 15	100	223	175	58.9	202	278	200	275
21000	- 17	100	221	174	58.5	201	281	199	278
22000	- 19	100	220	172	58.0	200	283	198	280
23000	- 21	100	218	171	57.5	199	286	196	284
24000	- 22	100	216	170	57.1	198	290	195	286
25000	- 24	100	215	169	56.8	197	293	194	289
26000	- 26	99	209	164	55.2	194	294	191	290
27000	- 28	95	202	159	53.5	190	292	187	287
28000	- 30	91	195	153	51.6	185	290	182	285
29000	- 32	88	188	148	49.8	181	288	177	282
30000	- 34	84	181	142	47.9	176	285	172	278
31000	- 36	81	174	136	45.9	171	282	166	275

Figure 9.41.13 - CRUISE PERFORMANCE -
 Maximum cruise / ISA

(*) Propeller RPM utilization between 1600 and 2000 RPM is possible without changing performance. Display the TRQ indicated in table with Np = 2000 RPM, then reduce Np without resetting power lever (within limits permitted by torque limiter).

CRUISE PERFORMANCE

Maximum cruiseConditions : **ISA + 5°C**

Landing gear and flaps UP

2000 RPM (*) - BLEED ON

NOTE :*Use preferably recommended cruise power*

Pressure altitude (feet)	IOAT (°C)	TRQ (%)	Fuel flow			AIRSPEEDS (kt)			
						6614 lbs (3000 kg)		7275 lbs (3300 kg)	
			l / h	kg / h	^{us} gal / h	IAS	TAS	IAS	TAS
0	+ 27	100	313	246	82.8	224	229	223	228
5000	+ 18	100	283	223	74.9	219	240	217	239
10000	+ 8	100	258	202	68.1	213	253	212	251
15000	- 1	100	238	187	62.9	207	265	205	263
18000	- 6	100	229	180	60.6	204	273	202	271
20000	- 10	100	224	176	59.3	201	279	199	276
21000	- 12	100	223	175	58.9	200	282	198	279
22000	- 14	100	221	174	58.5	199	285	197	282
23000	- 16	100	220	172	58.0	198	288	195	286
24000	- 17	100	218	172	57.7	197	291	194	288
25000	- 19	97	211	166	55.9	194	292	192	288
26000	- 21	94	204	161	54.0	190	291	187	286
27000	- 23	90	197	155	52.0	185	289	182	283
28000	- 25	87	190	149	50.1	181	287	177	281
29000	- 27	83	182	143	48.2	176	284	172	277
30000	- 29	80	176	138	46.4	171	280	166	273
31000	- 31	76	168	132	44.5	166	277	160	268

Figure 9.41.14 - CRUISE PERFORMANCE -
Maximum cruise / ISA + 5°C

(*) Propeller RPM utilization between 1600 and 2000 RPM is possible without changing performance. Display the TRQ indicated in table with Np = 2000 RPM, then reduce Np without resetting power lever (within limits permitted by torque limiter).

CRUISE PERFORMANCE

Maximum cruise

Conditions : **ISA + 10°C**
 Landing gear and flaps UP
 2000 RPM (*) - BLEED ON

NOTE :
 Use preferably recommended cruise power

Pressure altitude (feet)	IOAT (°C)	TRQ (%)	Fuel flow			AIRSPEEDS (kt)			
						6614 lbs (3000 kg)		7275 lbs (3300 kg)	
			l / h	kg / h	^{us} gal / h	IAS	TAS	IAS	TAS
0	+ 32	100	315	247	83.2	223	230	222	229
5000	+ 23	100	285	224	75.4	218	242	217	240
10000	+ 13	100	259	203	68.4	213	254	211	252
15000	+ 4	100	240	188	63.3	206	267	204	264
18000	- 1	100	231	181	60.9	203	275	201	272
20000	- 5	100	226	177	59.7	200	281	198	278
21000	- 7	100	224	176	59.2	199	284	197	280
22000	- 9	100	223	175	58.9	198	286	196	283
23000	- 11	98	218	171	57.6	197	289	193	285
24000	- 13	96	211	166	55.7	193	288	190	284
25000	- 15	92	204	160	53.9	189	287	186	282
26000	- 17	89	197	155	52.0	184	285	181	280
27000	- 19	86	190	150	50.3	180	283	176	278
28000	- 20	82	184	144	48.5	175	281	171	274
29000	- 22	79	176	139	46.6	171	278	166	271
30000	- 24	75	170	133	44.9	165	275	160	266
31000	- 26	72	163	128	43.0	160	271	154	261

Figure 9.41.15 - CRUISE PERFORMANCE -
 Maximum cruise / ISA + 10°C

(*) Propeller RPM utilization between 1600 and 2000 RPM is possible without changing performance. Display the TRQ indicated in table with Np = 2000 RPM, then reduce Np without resetting power lever (within limits permitted by torque limiter).

CRUISE PERFORMANCE

Maximum cruise

Conditions : **ISA + 20°C**
 Landing gear and flaps UP
 2000 RPM (*) - BLEED ON

NOTE :
 Use preferably recommended cruise power

Pressure altitude (feet)	IOAT (°C)	TRQ (%)	Fuel flow			AIRSPEEDS (kt)			
						6614 lbs (3000 kg)		7275 lbs (3300 kg)	
			l / h	kg / h	^{us} gal / h	IAS	TAS	IAS	TAS
0	+ 42	100	319	250	84.3	222	233	221	231
5000	+ 33	100	289	227	76.3	217	244	215	243
10000	+ 23	100	262	206	69.3	211	257	209	254
15000	+ 14	100	243	190	64.1	205	269	203	267
18000	+ 9	100	234	183	61.7	201	278	199	275
20000	+ 4	97	225	177	59.4	197	282	195	278
21000	+ 2	94	218	171	57.5	193	280	190	276
22000	0	92	211	166	55.7	190	280	187	276
23000	- 2	88	204	160	53.9	186	278	181	273
24000	- 3	86	197	155	52.0	182	277	178	272
25000	- 5	82	190	149	50.2	178	275	174	270
26000	- 7	79	183	144	48.3	173	273	169	266
27000	- 9	76	176	139	46.6	168	270	163	263
28000	- 11	72	170	133	44.8	163	266	157	258
29000	- 13	69	163	128	43.1	157	263	151	253
30000	- 15	66	156	122	41.2	152	258	144	246
31000	- 17	62	150	117	39.5	145	252	136	236

**Figure 9.41.16 - CRUISE PERFORMANCE -
 Maximum cruise / ISA + 20°C**

(*) Propeller RPM utilization between 1600 and 2000 RPM is possible without changing performance. Display the TRQ indicated in table with Np = 2000 RPM, then reduce Np without resetting power lever (within limits permitted by torque limiter).

CRUISE PERFORMANCE

Normal (recommended) cruise

Conditions : **ISA - 20°C**
 Landing gear and flaps UP
 2000 RPM (*) - BLEED ON

NOTE :

Power recommended by PRATT & WHITNEY CANADA

Pressure altitude (feet)	IOAT (°C)	TRQ (%)	Fuel flow			AIRSPEEDS (kt)			
						6614 lbs (3000 kg)		7275 lbs (3300 kg)	
			l / h	kg / h	us gal / h	IAS	TAS	IAS	TAS
0	+ 2	100	304	239	80.3	228	223	227	222
5000	- 8	100	275	216	72.6	223	234	221	232
10000	- 17	100	250	196	66.0	218	245	216	244
15000	- 26	100	232	182	61.2	212	258	210	256
18000	- 32	100	223	175	58.9	208	266	206	263
20000	- 36	100	218	171	57.6	206	271	204	269
21000	- 37	100	216	170	57.1	205	274	203	271
22000	- 39	100	214	168	56.5	204	277	202	274
23000	- 41	100	212	166	56.0	203	280	201	277
24000	- 43	100	210	165	55.6	202	283	200	280
25000	- 45	100	209	164	55.3	201	286	198	283
26000	- 46	100	208	163	54.9	200	289	197	286
27000	- 48	100	207	162	54.7	198	292	196	289
28000	- 50	100	206	162	54.4	197	295	195	292
29000	- 52	100	206	161	54.3	196	299	194	295
30000	- 54	100	205	161	54.2	195	302	192	297
31000	- 56	95	198	155	52.2	191	300	187	295

Figure 9.41.17 - CRUISE PERFORMANCE -
 Normal cruise / ISA - 20°C

(*) Propeller RPM utilization between 1600 and 2000 RPM is possible without changing performance. Display the TRQ indicated in table with Np = 2000 RPM, then reduce Np without resetting power lever (within limits permitted by torque limiter).

CRUISE PERFORMANCE

Normal (recommended) cruise

Conditions : **ISA - 10°C**
 Landing gear and flaps UP
 2000 RPM (*) - BLEED ON

NOTE :

Power recommended by PRATT & WHITNEY CANADA

Pressure altitude (feet)	IOAT (°C)	TRQ (%)	Fuel flow			AIRSPEEDS (kt)			
						6614 lbs (3000 kg)		7275 lbs (3300 kg)	
			l / h	kg / h	^{us} gal / h	IAS	TAS	IAS	TAS
0	+ 12	100	308	242	81.4	227	226	225	224
5000	+ 2	100	279	219	73.6	221	236	220	235
10000	- 7	100	254	199	67.0	216	248	214	247
15000	- 16	100	234	184	61.9	210	261	208	258
18000	- 22	100	225	177	59.4	207	269	204	266
20000	- 25	100	220	173	58.2	204	274	202	272
21000	- 27	100	218	171	57.6	203	277	201	275
22000	- 29	100	216	170	57.1	202	280	200	277
23000	- 31	100	215	168	56.7	201	283	199	280
24000	- 33	100	213	167	56.3	200	286	197	283
25000	- 34	100	212	166	55.9	198	289	196	286
26000	- 36	100	210	165	55.6	197	292	195	289
27000	- 38	99	207	162	54.7	195	293	192	289
28000	- 40	96	199	157	52.7	190	292	187	287
29000	- 42	92	193	151	50.9	186	290	183	285
30000	- 44	88	185	145	48.9	182	288	178	282
31000	- 46	85	179	140	47.2	177	286	173	279

Figure 9.41.18 - CRUISE PERFORMANCE -
 Normal cruise / ISA - 10°C

(*) Propeller RPM utilization between 1600 and 2000 RPM is possible without changing performance. Display the TRQ indicated in table with Np = 2000 RPM, then reduce Np without resetting power lever (within limits permitted by torque limiter).

CRUISE PERFORMANCE

Normal (recommended) cruise

Conditions : **ISA - 5°C**
 Landing gear and flaps UP
 2000 RPM (*) - BLEED ON

NOTE :
 Power recommended by PRATT & WHITNEY CANADA

Pressure altitude (feet)	IOAT (°C)	TRQ (%)	Fuel flow			AIRSPEEDS (kt)			
						6614 lbs (3000 kg)		7275 lbs (3300 kg)	
			l / h	kg / h	^{us} gal / h	IAS	TAS	IAS	TAS
0	+ 17	100	310	243	81.8	226	227	224	225
5000	+ 8	100	280	220	74.1	220	238	219	236
10000	- 2	100	255	200	67.4	215	250	213	248
15000	- 11	100	235	185	62.2	209	262	207	260
18000	- 17	100	226	178	59.8	206	270	203	268
20000	- 20	100	222	174	58.6	203	276	201	273
21000	- 22	100	220	173	58.1	202	279	200	276
22000	- 24	100	218	171	57.5	201	282	199	279
23000	- 26	100	216	170	57.1	200	285	198	282
24000	- 28	100	215	168	56.7	199	288	196	285
25000	- 29	100	213	167	56.3	198	291	195	287
26000	- 31	98	208	163	54.9	194	291	192	287
27000	- 33	95	201	158	53.1	190	289	187	285
28000	- 35	91	195	153	51.4	185	287	182	282
29000	- 37	87	188	147	49.6	181	285	177	279
30000	- 39	83	181	142	47.7	176	283	172	276
31000	- 41	80	172	135	45.4	171	280	167	273

Figure 9.41.19 - CRUISE PERFORMANCE -
 Normal cruise / ISA - 5°C

(*) Propeller RPM utilization between 1600 and 2000 RPM is possible without changing performance. Display the TRQ indicated in table with Np = 2000 RPM, then reduce Np without resetting power lever (within limits permitted by torque limiter).

CRUISE PERFORMANCE

Normal (recommended) cruise

Conditions : **ISA**
 Landing gear and flaps UP
 2000 RPM (*) - BLEED ON

NOTE :
Power recommended by PRATT & WHITNEY CANADA

Pressure altitude (feet)	IOAT (°C)	TRQ (%)	Fuel flow			AIRSPEEDS (kt)			
						6614 lbs (3000 kg)		7275 lbs (3300 kg)	
			l / h	kg / h	^{us} gal / h	IAS	TAS	IAS	TAS
0	+ 22	100	312	245	82.3	225	228	223	227
5000	+ 13	100	282	221	74.5	220	239	218	238
10000	+ 3	100	257	201	67.8	214	251	212	249
15000	- 6	100	237	186	62.5	208	264	206	261
18000	- 12	100	228	179	60.2	205	272	203	269
20000	- 15	100	223	175	58.9	202	278	200	275
21000	- 17	100	221	174	58.5	201	281	199	278
22000	- 19	100	220	172	58.0	200	283	198	280
23000	- 21	100	218	171	57.5	199	286	196	283
24000	- 22	100	216	170	57.1	198	290	195	286
25000	- 24	97	209	164	55.3	194	289	191	285
26000	- 26	94	203	159	53.6	190	288	187	283
27000	- 28	90	196	154	51.9	185	286	182	281
28000	- 31	86	190	149	50.1	181	284	177	278
29000	- 33	83	183	144	48.3	176	281	172	274
30000	- 35	78	176	138	46.5	171	278	167	271
31000	- 37	76	166	130	43.9	166	275	160	266

Figure 9.41.20 - CRUISE PERFORMANCE - Normal cruise / ISA

(*) Propeller RPM utilization between 1600 and 2000 RPM is possible without changing performance. Display the TRQ indicated in table with Np = 2000 RPM, then reduce Np without resetting power lever (within limits permitted by torque limiter).

CRUISE PERFORMANCE

Normal (recommended) cruise

Conditions : **ISA + 5°C**
 Landing gear and flaps UP
 2000 RPM (*) - BLEED ON

NOTE :
 Power recommended by PRATT & WHITNEY CANADA

Pressure altitude (feet)	IOAT (°C)	TRQ (%)	Fuel flow			AIRSPEEDS (kt)			
						6614 lbs (3000 kg)		7275 lbs (3300 kg)	
			l / h	kg / h	^{us} gal / h	IAS	TAS	IAS	TAS
0	+ 27	100	313	246	82.8	224	229	223	228
5000	+ 18	100	283	223	74.9	219	240	217	239
10000	+ 8	100	258	202	68.1	213	253	212	251
15000	- 1	100	238	187	62.9	207	265	205	263
18000	- 6	100	229	180	60.6	204	273	202	271
20000	- 10	100	224	176	59.3	201	279	199	276
21000	- 12	100	223	175	58.9	200	282	198	279
22000	- 14	100	221	174	58.5	199	285	197	282
23000	- 16	97	216	170	57.1	196	286	194	282
24000	- 18	95	209	164	55.1	192	285	190	281
25000	- 20	92	202	159	53.4	188	284	186	279
26000	- 22	89	195	153	51.5	184	282	181	277
27000	- 24	84	188	148	49.8	180	280	176	275
28000	- 26	81	182	143	48.0	175	278	171	272
29000	- 28	78	175	137	46.2	171	275	166	268
30000	- 30	74	171	134	45.2	166	272	160	264
31000	- 32	71	161	126	42.5	161	269	154	259

Figure 9.41.21 - CRUISE PERFORMANCE -
 Normal cruise / ISA + 5°C

(*) Propeller RPM utilization between 1600 and 2000 RPM is possible without changing performance. Display the TRQ indicated in table with Np = 2000 RPM, then reduce Np without resetting power lever (within limits permitted by torque limiter).

CRUISE PERFORMANCE

Normal (recommended) cruise

Conditions : **ISA + 10°C**
 Landing gear and flaps UP
 2000 RPM (*) - BLEED ON

NOTE :

Power recommended by PRATT & WHITNEY CANADA

Pressure altitude (feet)	IOAT (°C)	TRQ (%)	Fuel flow			AIRSPEEDS (kt)			
						6614 lbs (3000 kg)		7275 lbs (3300 kg)	
			l / h	kg / h	^{us} gal / h	IAS	TAS	IAS	TAS
0	+ 32	100	315	247	83.2	223	230	222	229
5000	+ 23	100	285	224	75.4	218	242	217	240
10000	+ 13	100	259	203	68.4	213	254	211	252
15000	+ 4	100	240	188	63.3	206	267	204	264
18000	- 1	100	231	181	60.9	203	275	201	272
20000	- 6	100	226	177	59.7	200	281	198	278
21000	- 8	98	220	173	58.1	198	282	196	279
22000	- 10	96	214	168	56.5	195	282	192	278
23000	- 12	92	207	162	54.7	191	281	188	277
24000	- 13	90	200	157	52.8	187	279	184	275
25000	- 15	87	193	152	51.1	183	278	180	273
26000	- 17	83	187	147	49.4	178	276	175	271
27000	- 19	79	181	142	47.7	174	274	170	267
28000	- 21	76	174	137	46.0	169	271	164	264
29000	- 23	73	167	131	44.1	164	268	159	259
30000	- 25	69	166	130	43.9	159	264	153	254
31000	- 27	67	154	121	40.7	153	260	/	/

Figure 9.41.22 - CRUISE PERFORMANCE - Normal cruise / ISA + 10°C

NOTE :

No airspeed data means that the cruise speed obtained for these conditions is lower than Long Range cruise speed.

(*) Propeller RPM utilization between 1600 and 2000 RPM is possible without changing performance. Display the TRQ indicated in table with Np = 2000 RPM, then reduce Np without resetting power lever (within limits permitted by torque limiter).

CRUISE PERFORMANCE

Normal (recommended) cruise

Conditions : **ISA + 20°C**
 Landing gear and flaps UP
 2000 RPM (*) - BLEED ON

NOTE :

Power recommended by PRATT & WHITNEY CANADA

Pressure altitude (feet)	IOAT (°C)	TRQ (%)	Fuel flow			AIRSPEEDS (kt)			
						6614 lbs (3000 kg)		7275 lbs (3300 kg)	
			l / h	kg / h	^{us} gal / h	IAS	TAS	IAS	TAS
0	+ 42	100	319	250	84.3	222	233	221	231
5000	+ 33	100	289	227	76.3	217	244	215	243
10000	+ 23	100	262	206	69.3	211	257	209	254
15000	+ 14	100	243	190	64.1	205	269	203	267
18000	+ 9	96	226	177	59.7	198	273	195	270
20000	+ 4	90	213	167	56.3	191	272	188	268
21000	+ 2	87	206	162	54.4	187	272	184	267
22000	0	84	200	157	52.8	183	270	180	266
23000	- 2	81	193	152	51.0	179	269	176	264
24000	- 4	78	187	146	49.3	175	267	171	262
25000	- 6	76	180	141	47.6	171	265	167	259
26000	- 8	72	173	136	45.8	166	262	161	255
27000	- 10	69	167	131	44.1	161	259	155	250
28000	- 12	66	160	126	42.3	155	255	/	/
29000	- 14	63	157	120	40.6	150	251	/	/

Figure 9.41.23 - CRUISE PERFORMANCE -
 Normal cruise / ISA + 20°C

NOTE :

No airspeed data means that the cruise speed obtained for these conditions is lower than Long Range cruise speed.

(*) Propeller RPM utilization between 1600 and 2000 RPM is possible without changing performance. Display the TRQ indicated in table with Np = 2000 RPM, then reduce Np without resetting power lever (within limits permitted by torque limiter).

CRUISE PERFORMANCE

Intermediate cruise

Conditions : **ISA - 20°C**
 Landing gear and flaps UP
 2000 RPM (*) - BLEED ON

Pressure altitude (feet)	IOAT (°C)	TRQ (%)	Fuel flow			AIRSPEEDS (kt)			
						6614 lbs (3000 kg)		7275 lbs (3300 kg)	
			l / h	kg / h	us gal / h	IAS	TAS	IAS	TAS
0	+ 1	88	286	225	75.6	217	212	216	211
5000	- 8	88	257	202	68.0	212	223	210	221
10000	- 18	88	233	183	61.6	207	233	205	231
15000	- 27	88	214	168	56.5	201	245	199	243
18000	- 32	88	205	161	54.2	198	253	196	250
20000	- 36	88	200	157	52.8	196	258	193	255
21000	- 38	88	198	155	52.2	195	260	192	257
22000	- 40	88	195	153	51.6	193	263	191	260
23000	- 42	88	193	152	51.1	192	266	190	262
24000	- 44	88	192	151	50.7	191	268	189	265
25000	- 45	88	190	149	50.2	190	271	188	267
26000	- 47	88	188	148	49.7	189	274	186	270
27000	- 49	88	187	147	49.4	188	277	185	273
28000	- 51	88	186	146	49.1	187	280	184	275
29000	- 53	88	185	145	48.9	186	283	183	279
30000	- 54	87	183	144	48.3	184	285	181	280
31000	- 56	84.5	178	139	46.9	180	284	177	279

Figure 9.41.24 - CRUISE PERFORMANCE - Intermediate cruise / ISA - 20°C

(*) Propeller RPM utilization between 1600 and 2000 RPM is possible without changing performance. Display the TRQ indicated in table with Np = 2000 RPM, then reduce Np without resetting power lever (within limits permitted by torque limiter).

CRUISE PERFORMANCE

Intermediate cruise

Conditions : **ISA - 10°C**
 Landing gear and flaps UP
 2000 RPM (*) - BLEED ON

Pressure altitude (feet)	IOAT (°C)	TRQ (%)	Fuel flow			AIRSPEEDS (kt)			
						6614 lbs (3000 kg)		7275 lbs (3300 kg)	
			l / h	kg / h	us gal / h	IAS	TAS	IAS	TAS
0	+ 11	88	289	227	76.3	216	215	214	213
5000	+ 2	88	261	205	68.9	210	225	209	223
10000	- 7	88	236	185	62.3	205	236	203	234
15000	- 17	88	217	170	57.2	200	248	197	246
18000	- 22	88	207	162	54.7	196	256	194	253
20000	- 26	88	202	159	53.4	194	261	191	257
21000	- 28	88	199	157	52.7	193	263	190	260
22000	- 30	88	198	155	52.2	192	266	189	263
23000	- 31	88	195	153	51.6	190	269	188	265
24000	- 33	88	194	152	51.2	189	272	187	268
25000	- 35	88	192	151	50.7	188	274	185	270
26000	- 37	88	190	150	50.3	187	277	184	273
27000	- 39	85	185	146	49.0	183	276	180	272
28000	- 41	82	179	141	47.3	179	275	176	269
29000	- 43	79	173	135	45.6	175	273	171	267
30000	- 45	76	166	130	43.9	170	271	166	264
31000	- 47	74	162	127	42.7	167	270	162	262

Figure 9.41.25 - CRUISE PERFORMANCE - Intermediate cruise / ISA - 10°C

(*) Propeller RPM utilization between 1600 and 2000 RPM is possible without changing performance. Display the TRQ indicated in table with Np = 2000 RPM, then reduce Np without resetting power lever (within limits permitted by torque limiter).

CRUISE PERFORMANCE

Intermediate cruise

Conditions : **ISA - 5°C**
 Landing gear and flaps UP
 2000 RPM (*) - BLEED ON

Pressure altitude (feet)	IOAT (°C)	TRQ (%)	Fuel flow			AIRSPEEDS (kt)			
						6614 lbs (3000 kg)		7275 lbs (3300 kg)	
			l / h	kg / h	us gal / h	IAS	TAS	IAS	TAS
0	+ 17	88	290	228	76.7	215	216	213	215
5000	+ 7	88	262	206	69.3	209	226	208	225
10000	- 2	88	237	186	62.7	204	238	202	235
15000	- 12	88	218	171	57.5	199	250	196	247
18000	- 17	88	209	164	55.1	195	257	193	254
20000	- 21	88	203	160	53.7	193	262	190	259
21000	- 23	88	201	158	53.1	192	265	189	261
22000	- 25	88	199	156	52.5	191	267	188	264
23000	- 26	88	197	155	52.0	189	270	187	267
24000	- 28	88	195	153	51.5	188	273	186	269
25000	- 30	87.5	193	151	50.9	187	276	184	271
26000	- 32	84.7	187	146	49.3	183	274	180	270
27000	- 34	82	181	142	47.7	179	273	176	268
28000	- 36	79	174	137	46.0	175	272	171	266
29000	- 38	76	167	131	44.2	171	269	167	263
30000	- 40	73.3	161	126	42.5	166	267	162	260
31000	- 42	69.5	156	122	41.1	161	263	155	254

Figure 9.41.26 - CRUISE PERFORMANCE - Intermediate cruise / ISA - 5°C

(*) Propeller RPM utilization between 1600 and 2000 RPM is possible without changing performance. Display the TRQ indicated in table with Np = 2000 RPM, then reduce Np without resetting power lever (within limits permitted by torque limiter).

CRUISE PERFORMANCE

Intermediate cruise

Conditions : **ISA**
 Landing gear and flaps UP
 2000 RPM (*) - BLEED ON

Pressure altitude (feet)	IOAT (°C)	TRQ (%)	Fuel flow			AIRSPEEDS (kt)			
						6614 lbs (3000 kg)		7275 lbs (3300 kg)	
			l / h	kg / h	us gal / h	IAS	TAS	IAS	TAS
0	+ 22	88	292	229	77.1	214	217	213	216
5000	+ 12	88	264	207	69.8	209	227	207	226
10000	+ 3	88	239	188	63.1	203	239	201	237
15000	- 7	88	219	172	57.9	198	251	196	248
18000	- 12	88	210	165	55.5	194	258	192	255
20000	- 16	88	204	161	54.0	192	264	190	260
21000	- 18	88	202	159	53.5	191	266	188	263
22000	- 20	88	200	157	52.8	190	269	187	265
23000	- 21	88	198	156	52.4	189	272	186	268
24000	- 23	87.3	195	153	51.5	187	274	184	270
25000	- 25	84.3	188	148	49.8	183	273	180	268
26000	- 27	81.2	182	143	48.1	179	271	175	266
27000	- 29	78	176	138	46.4	174	269	170	263
28000	- 31	75	169	133	44.6	170	266	166	260
29000	- 33	72	162	128	42.9	165	264	160	256
30000	- 35	69	156	122	41.2	160	260	155	252
31000	- 37	66	151	118	39.8	155	256	/	/

Figure 9.41.27 - CRUISE PERFORMANCE - Intermediate cruise / ISA

NOTE :

No airspeed data means that the cruise speed obtained for these conditions is lower than Long Range cruise speed.

(*) Propeller RPM utilization between 1600 and 2000 RPM is possible without changing performance. Display the TRQ indicated in table with Np = 2000 RPM, then reduce Np without resetting power lever (within limits permitted by torque limiter).

CRUISE PERFORMANCE

Intermediate cruise

Conditions : **ISA + 5°C**
 Landing gear and flaps UP
 2000 RPM (*) - BLEED ON

Pressure altitude (feet)	IOAT (°C)	TRQ (%)	Fuel flow			AIRSPEEDS (kt)			
						6614 lbs (3000 kg)		7275 lbs (3300 kg)	
			l / h	kg / h	us gal / h	IAS	TAS	IAS	TAS
0	+ 27	88	293	230	77.5	213	218	212	217
5000	+ 17	88	266	209	70.2	208	229	206	227
10000	+ 8	88	240	188	63.4	203	240	201	238
15000	- 2	88	220	173	58.2	197	252	195	250
18000	- 7	88	211	166	55.8	193	260	191	257
20000	- 11	88	206	162	54.4	191	265	189	262
21000	- 13	88	204	160	53.9	190	268	187	264
22000	- 14	88	201	158	53.1	189	270	186	267
23000	- 16	85.6	195	153	51.5	185	270	183	266
24000	- 18	82.7	189	148	49.9	182	269	179	264
25000	- 20	79.8	182	143	48.2	178	267	174	262
26000	- 22	76.9	176	139	46.6	173	265	169	260
27000	- 24	74	170	134	45.0	169	263	165	257
28000	- 27	71	164	129	43.3	164	261	159	253
29000	- 29	68.1	157	124	41.6	159	258	/	/
30000	- 31	65.2	151	119	39.9	154	253	/	/
31000	- 33	62.5	146	114	38.5	149	250	/	/

Figure 9.41.28 - CRUISE PERFORMANCE - Intermediate cruise / ISA + 5°C

NOTE :

No airspeed data means that the cruise speed obtained for these conditions is lower than Long Range cruise speed.

(*) Propeller RPM utilization between 1600 and 2000 RPM is possible without changing performance. Display the TRQ indicated in table with Np = 2000 RPM, then reduce Np without resetting power lever (within limits permitted by torque limiter).

CRUISE PERFORMANCE

Intermediate cruise

Conditions : **ISA + 10°C**
 Landing gear and flaps UP
 2000 RPM (*) - BLEED ON

Pressure altitude (feet)	IOAT (°C)	TRQ (%)	Fuel flow			AIRSPEEDS (kt)			
						6614 lbs (3000 kg)		7275 lbs (3300 kg)	
			l / h	kg / h	us gal / h	IAS	TAS	IAS	TAS
0	+ 32	88	295	232	77.9	213	220	211	218
5000	+ 22	88	267	210	70.6	207	230	205	228
10000	+ 13	88	241	189	63.7	202	242	200	239
15000	+ 4	88	221	174	58.5	196	254	194	251
18000	- 2	88	212	167	56.1	193	261	190	258
20000	- 6	88	207	162	54.6	190	266	188	263
21000	- 8	86.5	201	158	53.1	188	267	185	263
22000	- 10	84	195	153	51.5	184	267	181	262
23000	- 12	81	190	149	50.1	180	265	177	261
24000	- 14	78	183	144	48.3	176	263	173	258
25000	- 16	75.5	177	139	46.8	172	262	168	256
26000	- 18	73	171	134	45.2	168	260	164	254
27000	- 20	70	165	130	43.6	163	258	158	250
28000	- 22	67	159	124	41.9	158	254	/	/
29000	- 24	64	153	120	40.3	152	250	/	/

Figure 9.41.29 - CRUISE PERFORMANCE -
 Intermediate cruise / ISA + 10°C

NOTE :

No airspeed data means that the cruise speed obtained for these conditions is lower than Long Range cruise speed.

(*) Propeller RPM utilization between 1600 and 2000 RPM is possible without changing performance. Display the TRQ indicated in table with Np = 2000 RPM, then reduce Np without resetting power lever (within limits permitted by torque limiter).

CRUISE PERFORMANCE

Intermediate cruise

Conditions : **ISA + 20°C**
 Landing gear and flaps UP
 2000 RPM (*) - BLEED ON

Pressure altitude (feet)	IOAT (°C)	TRQ (%)	Fuel flow			AIRSPEEDS (kt)			
						6614 lbs (3000 kg)		7275 lbs (3300 kg)	
			l / h	kg / h	us gal / h	IAS	TAS	IAS	TAS
0	+ 42	88	299	235	79.0	211	222	210	220
5000	+ 32	88	271	212	71.5	206	232	204	230
10000	+ 23	88	245	192	64.6	200	244	198	242
15000	+ 14	88	224	176	59.3	195	256	192	253
18000	+ 8	84	209	164	55.2	187	259	185	255
20000	+ 4	79	196	154	51.9	180	257	177	253
21000	+ 2	76.4	190	150	50.3	176	256	173	251
22000	0	74	184	144	48.6	173	255	169	249
23000	- 2	71.2	178	140	47.0	168	252	164	246
24000	- 4	69	172	135	45.4	164	251	160	244
25000	- 6	66	165	130	43.7	159	248	/	/
26000	- 8	63.4	159	125	42.1	154	244	/	/
27000	- 10	60.7	154	120	40.6	149	240	/	/

Figure 9.41.30 - CRUISE PERFORMANCE - Intermediate cruise / ISA + 20°C

NOTE :

No airspeed data means that the cruise speed obtained for these conditions is lower than Long Range cruise speed.

(*) Propeller RPM utilization between 1600 and 2000 RPM is possible without changing performance. Display the TRQ indicated in table with Np = 2000 RPM, then reduce Np without resetting power lever (within limits permitted by torque limiter).

CRUISE PERFORMANCE

Long Range Cruise (6614 lbs - 3000 kg)

Conditions : Landing gear and flaps UP
2000 RPM (*) - BLEED ON

LEGEND :	IOAT : °C	IAS : KIAS
	FF : us gal/h	
	FF : lbs/h	TAS : KTAS

Pressure altitude (feet)	TRQ (%)	ISA - 20°C		ISA - 10°C		ISA + 10°C		ISA + 20°C				
15000	55.5	- 28	164	- 18	163	- 8	161	2	160	12	158	
		44.4		45.0		45.6		46.1		46.7		306
		291	200	295	202	299	205	302	207	306	208	
18000	56.0	- 34	162	- 24	160	- 14	158	- 4	156	6	155	
		42.1		42.7		43.3		43.8		44.4		291
		276	206	280	209	284	210	287	212	291	214	
19000	56.5	- 36	161	- 26	159	- 16	157	- 6	156	4	154	
		41.6		42.1		42.7		43.3		43.8		287
		273	209	276	211	280	213	284	215	287	217	
20000	57.0	- 38	160	- 28	158	- 18	157	- 8	155	2	154	
		40.9		41.5		42.1		42.6		43.2		283
		268	212	272	214	276	216	279	218	283	220	
21000	57.5	- 40	160	- 30	158	- 20	156	- 10	155	0	153	
		40.4		40.9		41.5		42.1		42.6		279
		265	214	268	217	272	219	276	221	279	223	
22000	58.0	- 42	159	- 32	158	- 22	156	- 12	154	- 2	152	
		39.9		40.4		40.9		41.5		42.0		275
		261	217	265	220	268	222	272	224	275	225	
23000	58.5	- 44	159	- 34	157	- 24	155	- 14	154	- 4	152	
		39.6		40.1		40.6		41.1		41.5		272
		259	220	263	223	266	225	269	227	272	228	
24000	59.0	- 46	159	- 36	157	- 26	155	- 16	153	- 6	151	
		39.1		39.6		40.1		40.6		41.1		269
		256	223	259	226	263	228	266	230	269	231	

Figure 9.41.31 (1/2) - CRUISE PERFORMANCE -
Long Range Cruise (6614 lbs - 3000 kg) (Altitude ≤ 24000 ft)

(*) Propeller RPM utilization between 1600 and 2000 RPM is possible without changing performance. Display the TRQ indicated in table with Np = 2000 RPM, then reduce Np without resetting power lever (within limits permitted by torque limiter).

CRUISE PERFORMANCE

Long Range Cruise (6614 lbs - 3000 kg) (Cont'd)

Conditions : Landing gear and flaps UP
2000 RPM (*) - BLEED ON

LEGEND :	IOAT: °C	IAS : KIAS
	FF : us gal/h	
	FF : lbs/h	TAS: KTAS

Pressure altitude (feet)	TRQ (%)	ISA - 20°C		ISA - 10°C		ISA		ISA + 10°C		ISA + 20°C	
		IOAT	FF	IOAT	FF	IOAT	FF	IOAT	FF	IOAT	FF
24000	59.0	- 46	159	- 36	157	- 26	155	- 16	153	- 6	151
		39.1		39.6		40.1		40.6		41.1	
		256	223	259	226	263	228	266	230	269	231
25000	59.5	- 48	158	- 38	156	- 28	154	- 18	152	- 8	150
		38.8		39.3		39.8		40.3		40.8	
		254	227	257	229	261	231	264	233	267	234
26000	60.0	- 50	158	- 40	156	- 30	153	- 20	151	- 10	149
		38.4		38.9		39.4		39.9		40.4	
		252	229	255	232	258	234	261	235	265	237
27000	60.5	- 52	157	- 42	155	- 32	153	- 22	150	- 12	149
		38.2		38.7		39.1		39.6		40.2	
		250	233	254	235	256	236	259	238	263	240
28000	61.0	- 53	156	- 43	154	- 33	152	- 23	150	- 13	148
		38.0		38.4		38.9		39.4		39.9	
		249	235	252	237	255	239	258	241	261	243
29000	61.5	- 55	156	- 45	153	- 35	151	- 25	149	- 15	147
		37.8		38.3		38.8		39.2		39.7	
		248	239	251	240	254	243	257	244	260	246
30000	62.0	- 57	155	- 47	153	- 37	151	- 27	148	- 17	146
		37.7		38.1		38.6		39.0		39.5	
		247	241	250	243	253	246	255	247	259	249
31000	62.5	- 59	154	- 49	152	- 39	150	- 29	148	- 19	145
		37.5		38.0		38.5		38.9		39.4	
		246	245	249	247	252	249	255	251	258	252

Figure 9.41.31 (2/2) - CRUISE PERFORMANCE -
Long Range Cruise (6614 lbs - 3000 kg) (Altitude ≥ 24000 ft)

(*) Propeller RPM utilization between 1600 and 2000 RPM is possible without changing performance. Display the TRQ indicated in table with Np = 2000 RPM, then reduce Np without resetting power lever (within limits permitted by torque limiter).

CRUISE PERFORMANCE

Long Range Cruise (7275 lbs - 3300 kg)

Conditions : Landing gear and flaps UP
2000 RPM (*) - BLEED ON

LEGEND :	IOAT : °C	IAS : KIAS
	FF : us gal/h	
	FF : lbs/h	TAS : KTAS

Pressure altitude (feet)	TRQ (%)	ISA - 20°C		ISA - 10°C		ISA + 10°C		ISA + 20°C				
15000	62.5	- 28	171	- 18	169	- 8	167	2	165	12	164	
		47.1		47.7		48.3		48.9		49.5		215
		309	208	312	210	316	212	320	214	324	215	
18000	63.0	- 34	167	- 24	166	- 14	164	- 4	162	6	160	
		44.7		45.3		45.9		46.5		47.1		221
		293	214	297	216	301	218	305	220	309	221	
19000	63.5	- 36	167	- 26	165	- 16	163	- 6	161	4	160	
		44.1		44.6		45.2		45.8		46.5		225
		289	217	292	219	296	221	300	222	305	225	
20000	64.0	- 38	166	- 28	164	- 18	162	- 8	161	2	159	
		43.6		44.1		44.6		45.2		45.8		227
		286	219	289	221	292	223	296	225	300	227	
21000	64.5	- 40	166	- 30	164	- 20	162	- 10	160	0	158	
		43.1		43.7		44.2		44.7		45.3		230
		282	222	286	224	290	226	293	228	297	230	
22000	65.0	- 42	165	- 32	163	- 22	161	- 12	159	- 2	157	
		42.7		43.2		43.7		44.2		44.8		233
		280	225	283	227	286	229	290	231	293	233	
23000	65.5	- 44	165	- 34	163	- 24	161	- 14	159	- 4	156	
		42.3		42.8		43.3		43.8		44.4		235
		277	228	280	230	284	232	287	234	291	235	
24000	66.0	- 46	164	- 36	162	- 26	160	- 16	158	- 6	155	
		41.8		42.3		42.9		43.4		43.9		238
		274	231	277	233	281	235	284	236	288	238	

Figure 9.41.32 (1/2) - CRUISE PERFORMANCE -
Long Range Cruise (7275 lbs - 3300 kg) (Altitude ≤ 24000 ft)

(*) Propeller RPM utilization between 1600 and 2000 RPM is possible without changing performance. Display the TRQ indicated in table with Np = 2000 RPM, then reduce Np without resetting power lever (within limits permitted by torque limiter).

CRUISE PERFORMANCE

Long Range Cruise (7275 lbs - 3300 kg) (Cont'd)

Conditions : Landing gear and flaps UP
2000 RPM (*) - BLEED ON

LEGEND :	IOAT : °C	IAS : KIAS
	FF : us gal/h	
	FF : lbs/h	TAS : KTAS

Pressure altitude (feet)	TRQ (%)	ISA - 20°C		ISA - 10°C		ISA + 10°C		ISA + 20°C	
24000	66.0	- 46	164	- 36	162	- 26	160	- 16	158
		41.8		42.3		42.9		43.4	
		274	231	277	233	281	235	284	236
25000	66.5	- 48	163	- 38	161	- 28	159	- 18	157
		41.5		42.0		42.5		43.0	
		272	233	275	236	278	238	282	239
26000	67.0	- 50	163	- 40	160	- 30	158	- 20	156
		41.2		41.7		42.2		42.7	
		270	237	273	238	276	240	280	242
27000	67.5	- 52	162	- 42	159	- 32	157	- 22	155
		41.1		41.5		42.0		42.5	
		269	239	272	241	275	243	278	245
28000	68.0	- 53	161	- 43	159	- 33	156	- 23	154
		40.9		41.3		41.8		42.3	
		268	242	271	244	274	246	277	248
29000	68.5	- 55	160	- 45	158	- 35	156	- 25	153
		40.7		41.2		41.7		42.2	
		267	245	270	247	273	249	276	251
30000	69.0 (1)	- 57	160	- 47	157	- 37	155	- 27	152
		40.6		41.0		41.5		42.0	
		266	248	269	250	272	252	275	253
31000	69.5 (2)	- 59	159	- 49	156	- 39	154	- 29	151
		40.6		41.0		41.5		42.0	
		266	251	269	254	272	255	275	257

Figure 9.41.32 (2/2) - CRUISE PERFORMANCE -
Long Range Cruise (7275 lbs - 3300 kg) (Altitude ≥ 24000 ft)

(*) Propeller RPM utilization between 1600 and 2000 RPM is possible without changing performance. Display the TRQ indicated in table with Np = 2000 RPM, then reduce Np without resetting power lever (within limits permitted by torque limiter).

- (1) For conditions ISA + 20°C, performance are obtained according to usable maximum torque : 65 %
- (2) For conditions ISA + 20°C, performance are obtained according to usable maximum torque : 62 %

5.7 - LANDING DISTANCES

WEIGHT : 7024 lbs (3186 kg)

- Associated conditions :
- Landing gear DN and flaps LDG
 - Approach speed IAS = 85 KIAS
 - Touch-down speed IAS = 78 KIAS
 - Maximum braking without reverse
 - Hard, dry and level runway
 - GR = Ground roll (in ft)
 - D₅₀ = Landing distance (clear to 50 ft) (in ft)

PRESSURE ALTITUDE ft	ISA - 35°C		ISA - 20°C		ISA - 10°C		ISA	
	GR	D50	GR	D50	GR	D50	GR	D50
0	1575	2135	1675	2265	1740	2330	1840	2430
2000	1675	2265	1805	2395	1870	2495	1970	2590
4000	1805	2395	1940	2560	2035	2660	2135	2790
6000	1940	2560	2100	2725	2200	2855	2300	2955
8000	2100	2725	2265	2920	2360	3020	2495	3180
PRESSURE ALTITUDE ft	ISA + 10°C		ISA + 20°C		ISA + 30°C		ISA + 37°C	
	GR	D50	GR	D50	GR	D50	GR	D50
0	1905	2530	2000	2625	2070	2690	2135	2790
2000	2070	2690	2135	2790	2230	2890	2300	2955
4000	2230	2890	2330	2985	2430	3085	2495	3185
6000	2395	3050	2530	3215	2625	3315	2690	3380
8000	2590	3280	2725	3410	2855	3570	2920	3640

Figure 9.41.33 - LANDING DISTANCES - 7024 lbs (3186 kg)

- Corrections :
- . Reduce total distances of 10 % every 10 kt of headwind
 - . Increase total distances of 30 % every 10 kt of tail wind

Other runway surfaces require the following correction factors :

- Increase by :
- | | | | |
|------|----------------|------|--------------------|
| 7 % | on hard grass | 25 % | on high grass |
| 10 % | on short grass | 30 % | on slippery runway |
| 15 % | on wet runway | | |

SECTION 6

WEIGHT AND BALANCE

Information hereafter supplement or replace the one given for the TBM 700C1 airplane in Section 6 "Weight and balance" of the TBM 700C1 Pilot's Operating Handbook.

GENERAL

IT IS THE PILOT'S RESPONSIBILITY TO ENSURE THAT THE AIRPLANE IS LOADED PROPERLY AND THE WEIGHT AND BALANCE LIMITS ARE ADHERED TO.

If airplane empty weight has varied since last weighing form, refer to paragraph "DETERMINING EMPTY AIRPLANE CHARACTERISTICS" to determine new empty weight and the corresponding balance (for instance : optional equipment installation).

DETERMINING WEIGHT AND BALANCE

Refer to weight and balance graphs - Figure 9.41.34 or 9.41.34A.

REMINDER :

Maximum zero fuel weight (MZFW) : 6032 lbs (2736 kg)

①	②	③
Empty weight (W)	CG (MAC %)	Index calculation
		$I = \frac{(CG - 28) W}{600} + 80$
		Basic index

0 200 400 600 800 1000 1200 1400 1600 1800 2000 (lbs)

0 30 60 90 120 150 180 210 240 270 300 (US gal)

0 100 200 300 400 500 600 700 800 900 (kg)

0 200 400 600 800 1000 1200 (litres)

Empty weight	INDEX	
	10 20 30 40 50 60 70 80 90 100 110 120	
Front seats	100 kg	
Intcr. seats	50 kg	
Rear bench	50 kg	
Baggage in cabin	20 kg	
Rear baggage	10 kg	
Zero fuel weight	MZFW	Fueling (L)
	2736 kg	
Fuel (kg)	NO EFFECT	
TOTAL	MTOW	
	3354 kg	

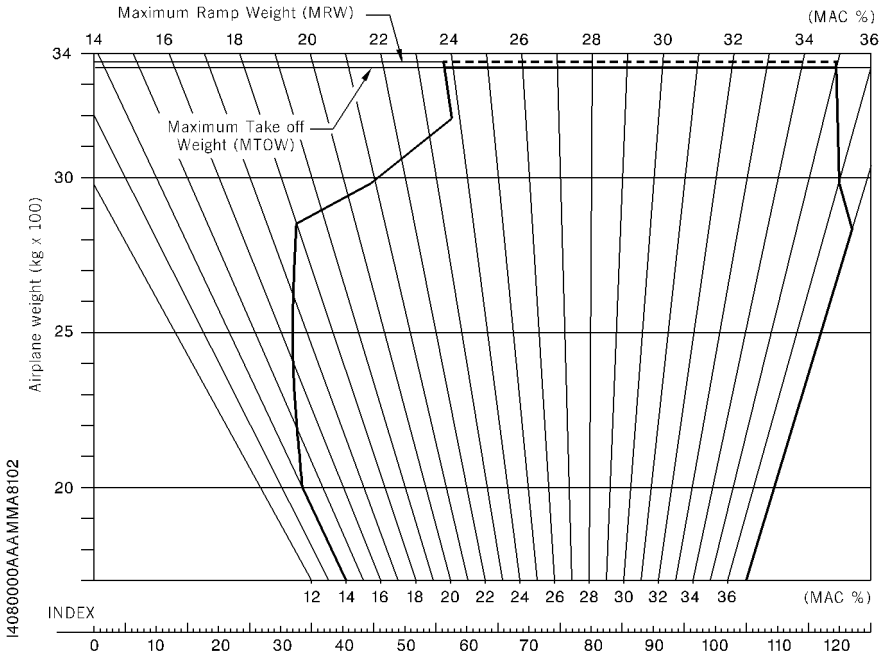

Figure 9.41.34 - WEIGHT AND BALANCE GRAPH (in Kg and Litres)

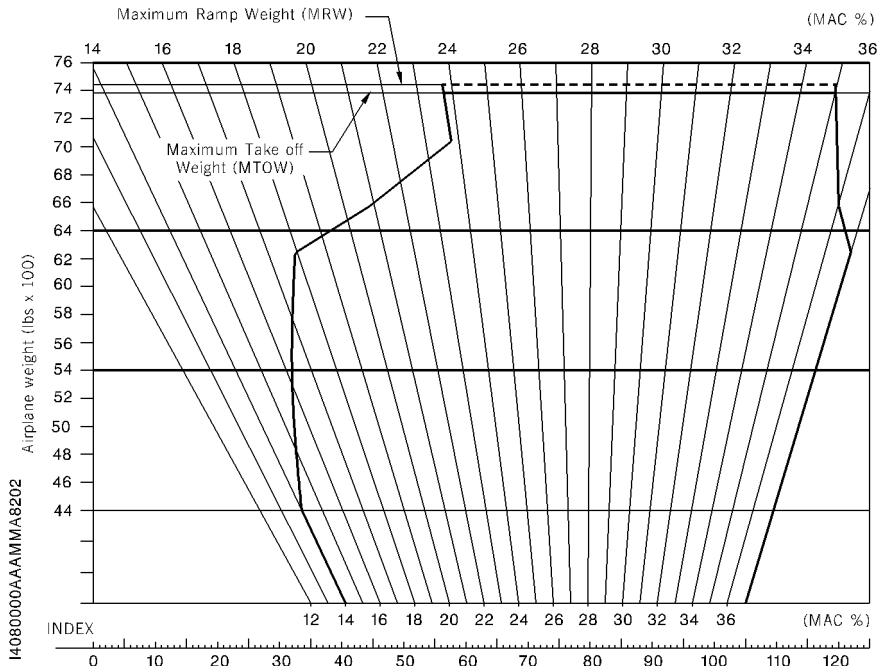
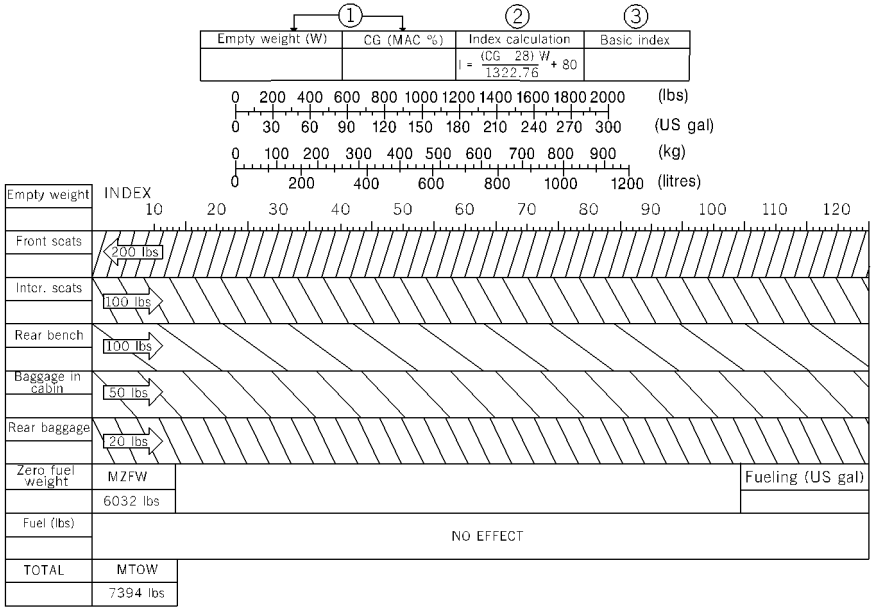

Figure 9.41.34A - WEIGHT AND BALANCE GRAPH (in lbs and us gal)

DETERMINING EMPTY AIRPLANE CHARACTERISTICS

Empty airplane characteristics (weight and balance) may vary with regard to those indicated on weighing form according to installed optional equipment.

List of equipment contains the standard and optional equipment, as well as their characteristics (weight, arm).

Use the chart below to compute new empty weight and corresponding balance if necessary.

DATE	EQUIPMENT OR MODIFICATION DESCRIPTION	(+) (-)	WEIGHT MODIFICATION			BASIC EMPTY WEIGHT		
			Weight lb	Arm in.	Moment lb.in/1000	Weight W	Arm "d _o "	Moment
	According to delivery							

Figure 9.41.35 - SAMPLE WEIGHT AND BALANCE RECORD

$$CG \text{ m.a.c.} \% = \frac{(d_o - 172.93)}{59.45} \times 100$$

Use the above formula to express arm "d_o" in % of mean aerodynamic chord.

NOTE :

Arm expressed in inches with regard to reference.

Post-
MOD70-148-25

Front seats	: 178.5 in. (4.534 m)	178.5 in. (4.534 m)
Intermediate seats	: 221.6 in. (5.630 m)	222.7 in. (5.656 m)
Rear bench (2 seats)	: 267.1 in. (6.785 m)	267.1 in. (6.785 m)
Baggage compartment in pressurized cabin	: 303.0 in. (7.695 m)	303.0 in. (7.695 m)
Aft baggage compartment	: 329.4 in. (8.366 m)	329.4 in. (8.366 m)
Fuel	: 189.8 in. (4.820 m)	189.8 in. (4.820 m)

LIST OF EQUIPMENT

S A or O	STANDARD OR OPTIONAL EQUIPMENT	EQUIPMENT SUPPLIER	WEIGHT per unit lb (kg)	ARM in. (m)
25 - EQUIPMENT - FURNISHINGS				
A	JEPPESEN filing cabinet (OPT70 25005D)	SOCATA	16.09 (7.300)	203.74 (5.175)
A	Storage box - Compositie (wood and leather) (OPT70 25006G) or <u>Post-MOD70-148-25</u>	SOCATA	17.64 (8.000)	203.74 (5.175) 205.79 (5.227)
A	Refreshment cabinet - Compositie (wood and leather) (OPT70 25006H) or <u>Post-MOD70-148-25</u>	SOCATA	20.28 (9.200)	203.74 (5.175) 205.79 (5.227)
S	Partition net at frame 14 (between the cabin and the baggage compartment) T700B2590001	SOCATA	1.698 (0.770)	289.53 (7.354)
Seats - Belts (Standard equipment)				
S	Seats			
	- Pilot's seat T700C2500002	SOCATA	55.12 (25.00)	183.90 (4.671)
	- Front R.H. seat T700C2500002	SOCATA	55.12 (25.00)	183.90 (4.671)
S O	- L.H. intermediate seat (back to flight direction) T700C2500003 or <u>Post-MOD70-148-25</u>	SOCATA	35.27 (16.00)	219.96 (5.587) 220.94 (5.612)
S O	- R.H. intermediate seat (back to flight direction) T700C2500003 or <u>Post-MOD70-148-25</u>	SOCATA	35.27 (16.00)	219.96 (5.587) 220.94 (5.612)
	- Double chair . L.H. seat T700C2500005 . R.H. seat T700C2500005	SOCATA	52.91 (24.00) 52.91 (24.00)	278.19 (7.066) 278.19 (7.066)

S A or O	STANDARD OR OPTIONAL EQUIPMENT	EQUIPMENT SUPPLIER	WEIGHT per unit lb (kg)	ARM in. (m)
	26 - FIRE PROTECTION			
S	Portable fire extinguisher unit 863520-00 (OPT70 26001B)	L'HOTELLIER	3.64 (1.650)	194.17 (4.932)
	32 - LANDING GEARS			
	32-10 - Main landing gear			
O	L.H. Main landing gear D23767001 (OPT70 0190-32)	MESSIER DOWTY	53.79 (24.400)	200.39 (5.090)
O	R.H. Main landing gear D23768001 (OPT70 0190-32)	MESSIER DOWTY	53.79 (24.400)	200.39 (5.090)
	32-20 - Nose landing gear			
R	Nose gear D23766000 (OPT70 0134-32)	MESSIER DOWTY	53.57 (24.300)	93.70 (2.380)
	32-40 - Wheels and brakes			
R	Main tire 18x5.5-10PR	MICHELIN	13.50 (6.123)	204.33 (5.190)
R	Main tire 18x5.5-10PR (OPT70 0409-32)	GOODYEAR	14.40 (6.530)	204.33 (5.190)
R	Main wheel (Model 40-434)	PARKER	11.28 (5.120)	204.33 (5.190)

S A or O	STANDARD OR OPTIONAL EQUIPMENT	EQUIPMENT SUPPLIER	WEIGHT per unit lb (kg)	ARM in. (m)
34 - NAVIGATION				
34-11 - Air data systems				
O	Airspeed indicator # 1 8040 Code B.850	UNITED INSTRUMENTS	0.75 (0.340)	157.48 (4.000)
R	Airspeed indicator # 1 8140 Code B.851 (OPT70 34011B)	UNITED INSTRUMENTS	0.75 (0.340)	157.48 (4.000)
O	Airspeed indicator # 2 8040 Code B.850 R.H. Instrument panel (OPT70 34019C)	UNITED INSTRUMENTS	0.75 (0.340)	157.48 (4.000)
S	TAS airspeed indicator # 2 8140 Code B.851 R.H. Instrument panel (OPT70 34019D)	UNITED INSTRUMENTS	0.75 (0.340)	157.48 (4.000)
S	Authorization to operate in RVSM area (OPT70 0160-34A)		/	/
77 - ENGINE INDICATING				
R	Torque transducer CZ 52E8-G	AUXITROL/ SAGEM	0.452 (0.205)	55.12 (1.400)

INTENTIONALLY LEFT BLANK

SECTION 7

DESCRIPTION

■ SEATS, BELTS AND HARNESSSES (Figures 9.41.36 and 9.41.37)

Cockpit seats

L.H. and R.H. front seats are mounted on rails attached to the structure. Longitudinal position, height and back-rest tilting of each seat can be adjusted and the arm-rest is hinged.

Pull up the handle located forward for longitudinal setting.

The seat height is adjusted by pulling up side forward handle while relieving the seat from the body weight.

The seat back angle is adjusted by pulling up side rearward handle.

Passengers' seats

The accommodation consists of :

- two individual seats, installed back to the flight direction, mounted on the same rails as the front seats.

The seat back angle is adjusted by pulling up side handle.

- two rear seats arranged as a bench, mounted on the same rails as the front seats.

The seat back-rests tilt forward by pulling up a rear handle and each seat may tilt forwards by pulling up a side rear handle to ease baggage loading in baggage compartment.

For longitudinal setting pull up the handle located forward.

Belts and harnesses

WARNING

INCORRECT CLOSURE OF THE SAFETY BELT MAY INTRODUCE A RISK. MAKE SURE IT IS TIGHTENED WHEN BUCKLED. TO BE MOST EFFICIENT, THE BELT MUST NOT BE TWISTED. CHECK THAT THERE IS NO CONSTRAINT WHEN OPERATED. AFTER A SERIOUS ACCIDENT, REPLACE ALL BELTS

Each cockpit seat is equipped with a four-point restraint system consisting of an adjustable lap belt and a dual-strap inertia reel-type shoulder harness.

Each passenger seat is equipped with a three-point restraint system consisting of an adjustable lap belt and an inertia reel-type shoulder harness.

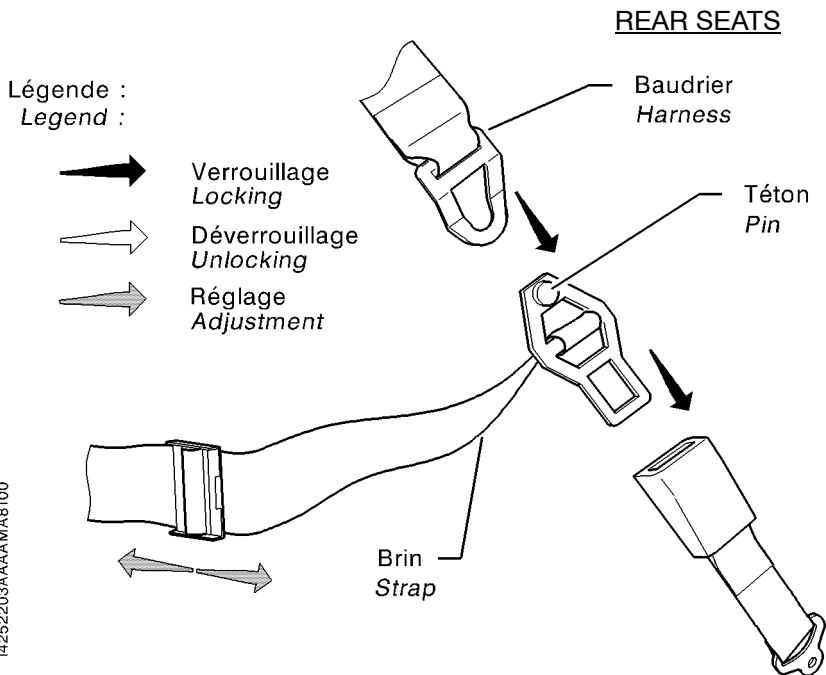
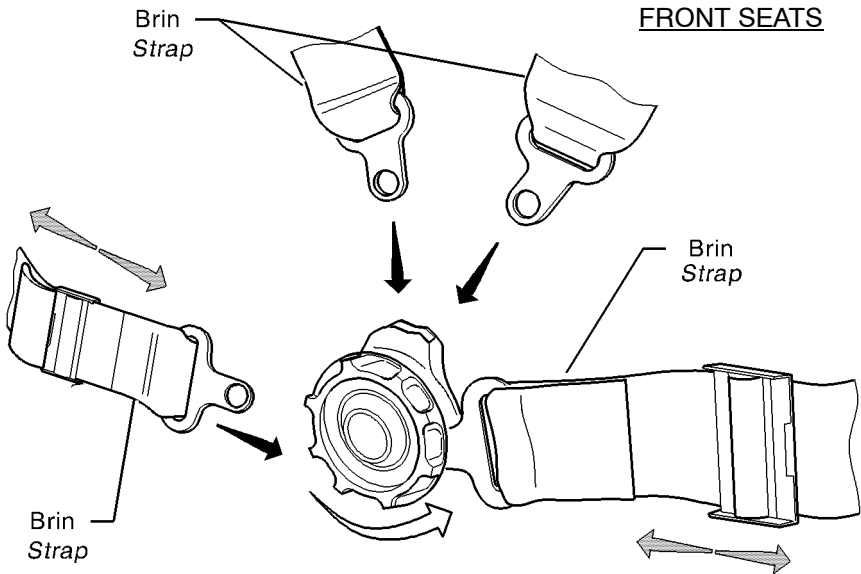

14252203AAAAWA6100

Figure 9.41.36 - FRONT AND REAR SEAT BELTS (with movable straps) AND HARNESSSES

- 1) Front passenger's seat
- 2) L. H. pilot's seat
- 3) R. H. intermediate passenger's seat (back to flight direction)
- 4) L. H. intermediate passenger's seat (back to flight direction)
- 5) R. H. rear passenger's seat
- 6) L. H. rear passenger's seat } Rear bench
- 7) Front seat(s) longitudinal shift control
- 8) Front seat(s) height control
- 9) Front seat(s) back-rest tilt control
- 10) Drawer for pilot's piddle pak
(front side : new bags, rear side : used bags)
- 11) Intermediate seat(s) back-rest tilt control
- 12) Rear bench seat(s) back-rest tilt control
- 13) Rear bench L.H. seat tilt control

NOTE :

To have access to the baggage compartment, pull forwards the back-rest of rear bench L.H. seat, then pull forwards control (Item 13) to tilt L.H. seat assembly forwards.

If necessary, pull forwards the back-rest of rear bench R.H. seat.

Figure 9.41.37 (1/2) - SEATS

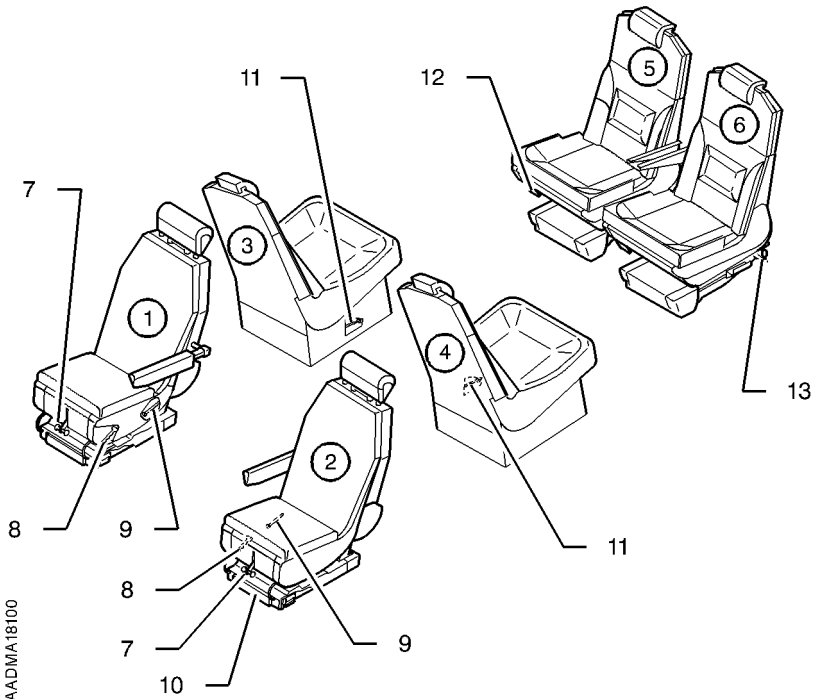

14251100AAADMA 18100

Figure 9.41.37 (2/2) - SEATS

SECTION 8

HANDLING, SERVICING AND MAINTENANCE

8.1 - SERVICING

LANDING GEAR

Main gear tires :

18 5.5 10 PR – Inflating pressure : 135 psi (9.32 bars) *

(*) Tire inflation pressures are given for an airplane on ground at 21 °C.
 An ambient temperature change of 3°C produces approximately 1 % pressure change.

8.2 - UTILIZATION BY COLD WEATHER (- 0°C TO - 25°C) OR VERY COLD WEATHER (- 25°C TO - 40°C)

NOTE :

Check pressure values in a hangar heated at about 15°C with control equipment at room temperature.

	OAT (° C)	- 40°	- 30°	- 20°	- 10°	+ 15°
PRESSURES psi (bars)	Main landing gear tire	144 (9.96)	144 (9.96)	130 (8.96)	130 (8.96)	130 (8.96)

Table 1

SUPPLEMENT**"HONEYWELL" KMH 880
EGPWS/TAS SYSTEM****TABLE OF CONTENTS**

	Page
1 - GENERAL	9.42.3
2 - LIMITATIONS	9.42.4
3 - EMERGENCY PROCEDURES	9.42.5
4 - NORMAL PROCEDURES	9.42.6
5 - PERFORMANCE	9.42.9
6 - WEIGHT AND BALANCE	9.42.9
7 - DESCRIPTION	9.42.10

INTENTIONALLY LEFT BLANK

SECTION 1**GENERAL**

This supplement is intended to inform the pilot about the equipment limitations, description and operations necessary to the operation when the TBM airplane is equipped with the option "HONEYWELL" KMH 880 EGPWS/TAS SYSTEM.

The KMH 880 system provides two functions which are aids for the pilot :

- the EGPWS function enables to detect if the airplane path is in compliance with the overflown terrain relief.
- the TAS function enables to monitor the traffic by relying on information obtained from nearby airplane transponders. This function does neither detect, nor track airplane which are not equipped with an operating ATCRBS transponder.

SECTION 2

LIMITATIONS

The limitations hereafter supplement those of the standard airplane described in Section 2 "Limitations" of the basic Pilot's Operating Handbook, when the TBM airplane is equipped with the option "HONEYWELL" KMH 880 EGPWS/TAS SYSTEM.

The KMH 880 EGPWS function provides terrain proximity alerting and detection to the pilot. It must not be used for airplane vertical and horizontal navigation.

AC 2318 recommendation : in order to avoid unwillingly warnings, EGPWS function must be inhibited for any landing on a terrain which is not mentioned in the data base.

REMARK :

The KMH 880 TAS function is an advisory means, not a TCAS.

Following documents or any further edition applicable to the latter, shall be readily available to the pilot, each time the KMH 880 system is used :

- KTA 870/KMH 880 Traffic Advisory System/Multi-Hazard Awareness System Pilot's Guide, P/N 006-18265-0000 Revision 0 dated 03/01,
 - EFS 40/50 Pilot's Guide, P/N 006-08701-0000 dated 08/15/93,
 - "GARMIN" GNS 530 Pilot's Guide, P/N 190-00181-00 Revision A dated 04/00, if data are displayed on a GNS 530 GPS,
- and, depending of the multi-function display used, :
- KMD 550/850 Multi-function Display Pilot's Guide, P/N 006-18222-0000 Revision 1 dated April/2001,
 - KMD 550/850 Multi-function Display/Terrain Function (EGPWS) Pilot's Guide Addendum, P/N 006-18236-0000 Revision 1 dated April/2001,
 - Multi-function Display Traffic Avoidance Function (TCAS/TAS) Pilot's Guide Addendum P/N 006-18238-0000 Revision 0 dated 04/01, if data are displayed on a KMD 850 MFD,

or

- "GARMIN" GMX 200 Multi-function Display Pilot's Guide, P/N 190-00607-02 Revision A dated June 2006, if data are displayed on a GMX 200 MFD.

SECTION 3
EMERGENCY PROCEDURES

The emergency procedures hereafter supplement those of the standard airplane described in Section 3 "Emergency procedures" of the basic Pilot's Operating Handbook, when the TBM airplane is equipped with the option "HONEYWELL" KMH 880 EGPWS/TAS SYSTEM.

WARNING LIGHT "TERR N/A" ON

1 - MD41 "TEST" switch **PUSH**

If the following voice message is heard :

"EGPWS Computer OK - External faults : Display configuration"

or

"EGPWS Computer OK - External faults : Display bus inactive" :

2 - Check the multi-function display (KMD 850 or GMX 200) is set to ON.

For all other messages :

The EGPWS function is not operational.

SECTION 4

NORMAL PROCEDURES

The normal procedures hereafter supplement those of the standard airplane described in Section 4 "Normal procedures" of the basic Pilot's Operating Handbook, when the TBM airplane is equipped with the option "HONEYWELL" KMH 880 EGPWS/TAS SYSTEM.

BEFORE TAKEOFF

- 1 - MD41 "TEST" switch **PUSH**
- 2 - "EGPWS System OK" voice message **HEARD**
- 3 - If KMD 850 installed :
 - KMD 850 "TRFC" knob **PRESS**
 - TAS function test (KMD 850) **OK**
 - "TAS" knob (on KMD 850 "TRFC" page) **ON**
- 4 - If GMX 200 installed :
 - TAS function key (GMX 200) **ON**
 - TAS "Operate" item key (GMX 200) **PRESS**

4.1 - WARNINGS OF THE EGPWS FUNCTION

"PULL UP" AURAL WARNING

The red "TERR" warning light illuminates.

- 1 - Level the wings.
- 2 - Display the maximum power.
- 3 - Choose the optimum rate of climb adapted to airplane configuration and speed, until the warning disappears.

**"Terrain Terrain Pull up",
"Obstacle Obstacle Pull up",
AURAL WARNINGS**

The red "TERR" warning light illuminates.

Adjust airplane path in order to make the warning disappear.

4.2 - CAUTIONS OF THE EGPWS FUNCTION

**"Caution terrain", "Caution obstacle",
"Too low terrain"
AURAL WARNINGS**

The amber "TERR" warning light illuminates.

Adjust airplane path in order to make the warning disappear.

"DON'T SINK" AURAL WARNING

The amber "TERR" warning light illuminates.

Re-establish a positive rate of climb.

"SINK RATE" AURAL WARNING

The amber "TERR" warning light illuminates.

Reduce rate of descent.

4.3 - KMH 880 TAS FUNCTION**WARNING**

DO NOT ATTEMPT EVASIVE MANEUVERS BASED SOLELY ON TRAFFIC INFORMATION SHOWN ON DISPLAY ASSOCIATED TO THE KMH 880 TAS FUNCTION. INFORMATION ON THE DISPLAY IS PROVIDED TO THE FLIGHT CREW AS AN AID IN VISUALLY ACQUIRING TRAFFIC; IT IS NOT A REPLACEMENT FOR ATC AND SEE & AVOID TECHNIQUES

When the KMH 880 TAS function issues a Traffic Alert (aural or visual), look outside for the intruder airplane. When you spot an intruder airplane, use normal right-of-way procedures to maintain separation.

SECTION 5
PERFORMANCE

The installation and the operation of the "HONEYWELL" KMH 880 EGPWS/TAS SYSTEM do not change the basic performance of the airplane described in Section 5 "Performance" of the basic Pilot's Operating Handbook.

SECTION 6
WEIGHT AND BALANCE

Information hereafter supplement the one given for the standard airplane in Section 6 "Weight and balance" of the basic Pilot's Operating Handbook.

A or O	OPTIONAL EQUIPMENT	EQUIPMENT SUPPLIER	WEIGHT per unit lb (kg)	ARM in. (m)
34 - NAVIGATION				
A	EGPWS/TAS system (OPT70 34061A) KMH 880	HONEYWELL	15.63 (7.09)	158.42 (4.024)
A	EGPWS/TAS system (with antenna KA92) (OPT70 34061B) KMH 880	HONEYWELL	15.89 (7.21)	166.02 (4.217)
A	EGPWS/TAS system (OPT70 34061C) KMH 880	HONEYWELL	15.65 (7.10)	158.42 (4.024)

SECTION 7

DESCRIPTION

7.1 COMPONENTS OF THE OPTION

The KMH 880 option is constituted of the following components :

- a KA 92 GPS antenna (airplanes equipped with a "HONEYWELL" GPS),
- an MD41-1208 control box for EGPWS function of the option,
- a KMH 880 computer,
- two KA 815 antennas.

KMH 880 terrain type information is displayed on a KMD 850 or on a GMX 200 screen, when the "TERR" function is activated by the pilot.

Traffic information can be displayed on a dedicated screen (KMD 850 / GMX 200 and/or GNS 530) and/or on the EFS 40.

KMH 880 traffic type information is displayed on a KMD 850 or on a GMX 200 screen, when the "TRFC" function is activated by the pilot.

Use EFS 40 "TEST/REF" knob to display TAS information on the EFS 40.

7.2 MODES OF THE KMH 880 EGPWS FUNCTION

The KMH 880 EGPWS function has 5 modes :

- "Look ahead" mode

This mode provides a protection ahead of the airplane with a 1 minute prediction ("Caution terrain" or "Caution obstacle" aural warning associated with the illumination of the amber "TERR" warning light) and a 30 seconds prediction ("Terrain Terrain Pull up" or "Obstacle Obstacle Pull up" aural warning associated with the illumination of the red "TERR" warning light).

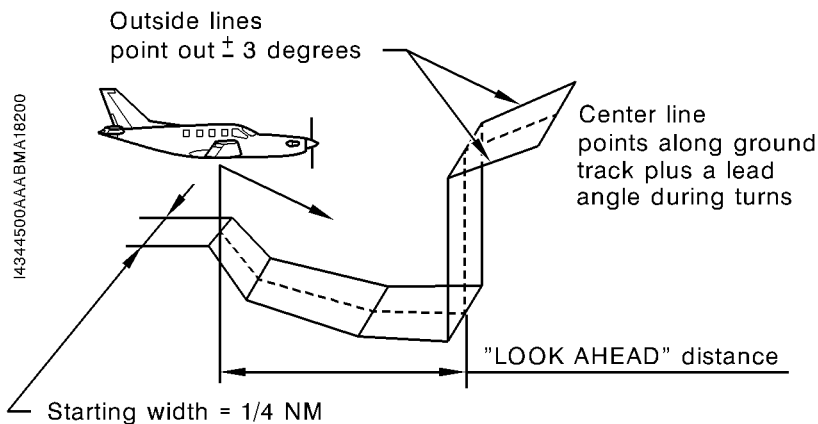

Figure 9.42.1

"HONEYWELL" **KMH 880** EGPWS/TAS SYSTEM

- "Runway Field Clearance Floor" (RFCF) mode

This mode is active, when the airplane flies at less than 5 NM from a runway known in the KMH 880 data base ; it generates the "Too low terrain" aural warning and the illumination of the amber "TERR" warning light.

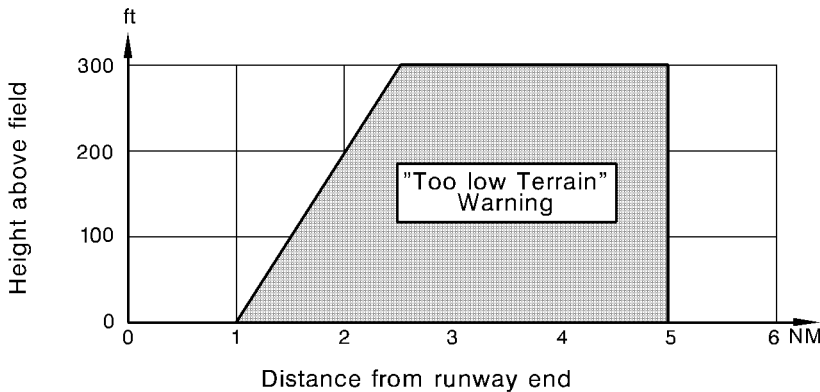

Figure 9.42.2 - "Too low terrain" warning area

- "Excessive rate of descent" mode

This mode has a lower priority than the "Look ahead" mode ; it generates the "Sink rate" aural warning (illumination of the amber "TERR" warning light) and the "Pull up" aural warning (illumination of the red "TERR" warning light).

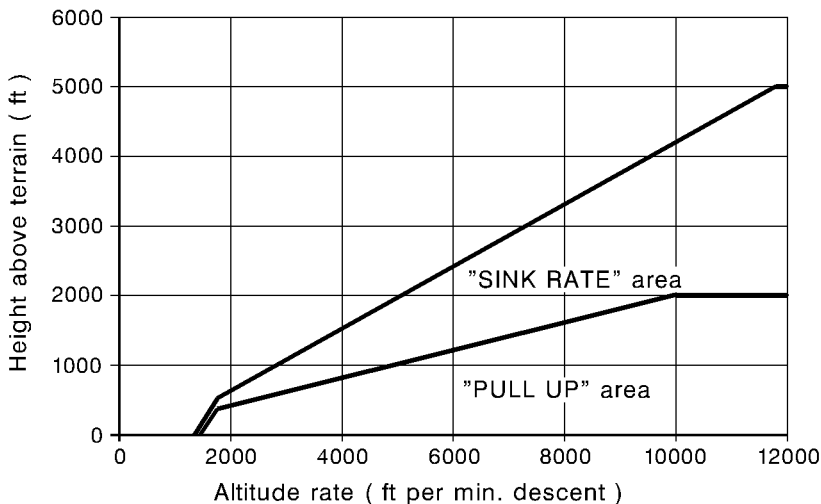

Figure 9.42.3 - "Sink rate" and "Pull up" warnings areas

- "Loss of altitude/negative rate of descent after takeoff" mode

This mode is active until the airplane reaches an altitude of approximately 700 ft above the runway ; it generates the "Don't sink" aural warning and the illumination of the amber "TERR" warning light.

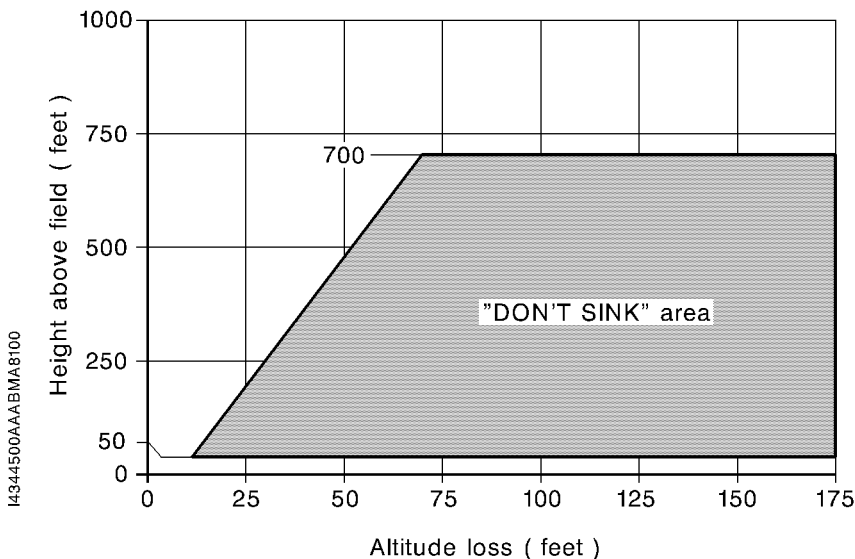

Figure 9.42.4 - "Don't sink" warning area

- "500 ft" mode

This mode is active, when the airplane flies at less than 5 NM from a runway known in the KMH 880 data base ; it generates a "500 ft" aural warning. This warning is re-initialized when the airplane reaches a height of 700 ft above the terrain altitude.

7.3 TERRAIN AWARENESS DISPLAY

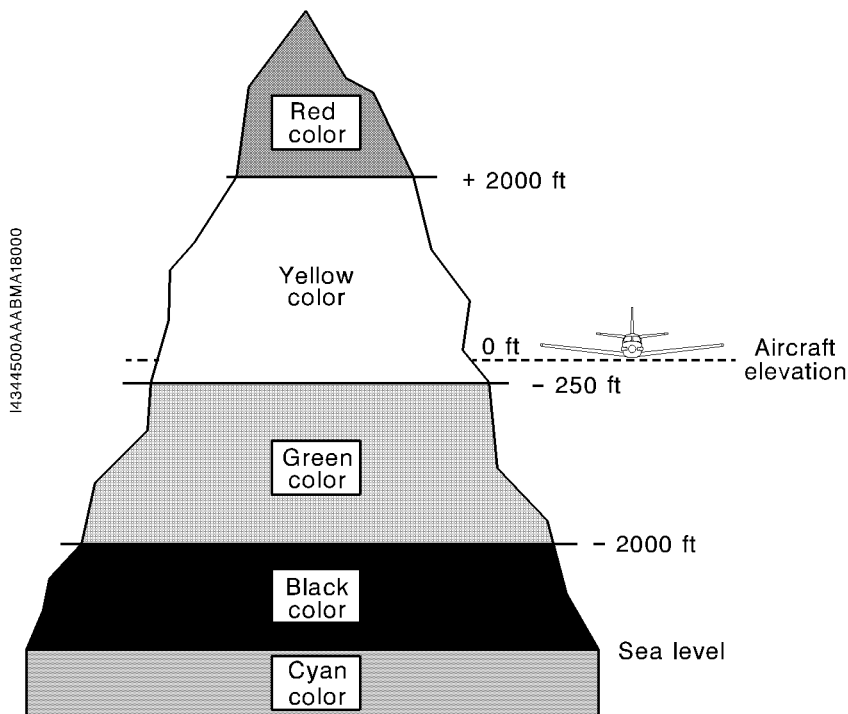

Figure 9.42.5

7.4 OBSTACLE DATA BASE

Data for known obstacles such as towers, buildings, antennas, etc. is contained on the same data card as the terrain and airport data. Presently, there are some 70000-plus obstacles in the database, but they are all in the area of North America. As more reliable information becomes available, Honeywell will expand the capability to provide alerting and warning for obstacles in other areas of the world.

Obstacles in the database are those known obstacles more than 100 feet AGL, so obstacles of lower height will not produce GA-EGPWS "Obstacle" alerts or warnings. However, terrain elevations are "rounded" up to the next 100 feet, so alerting and warning protection is generally available for known obstacles that are less than 100 feet AGL.

7.5 KMH 880 TAS FUNCTION

Traffic detected is displayed, when the vertical separation between your own airplane altitude and the intruder altitude ranges :

MODE	From	Up to
ABV (Look up)	- 2700 ft	+ 9000 ft
NRM (Normal)	- 2700 ft	+ 2700 ft
BLW (Below)	- 9000 ft	+ 2700 ft

Traffic Advisory (TA) criteria, which initiate a visual and/or an aural alert, are (sensitivity level B) :

- detection of an intruder airplane within a 0.55 NM horizontal radius and a \pm 800 ft relative altitude,
- approach of an intruder airplane on a course that will intercept your course within 20 to 30 seconds.

Airplanes equipped with the radio altimeter

When the airplane is at a ground height lower than 2000 ft, Traffic Advisory (TA) criteria, which initiate a visual and/or an aural alert, are (sensitivity level A) :

- detection of an intruder airplane within a 0.2 NM horizontal radius and a \pm 600 ft relative altitude,
- approach of an intruder airplane on a course that will intercept your course within 15 to 20 seconds.

The aural traffic alert is inhibited when the height detected by the radio altimeter is below 600 ft.

TAS function will be automatically activated, if following conditions are combined :

- radio altimeter height is greater than 50 ft,
- KMD 850 TAS selector (outer knob icon) is set to ON.

7.6 SWITCH-ON

To switch ON or OFF the KMH 880, use "RADIO MASTER" switch.

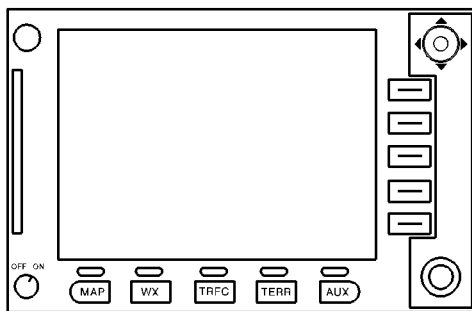
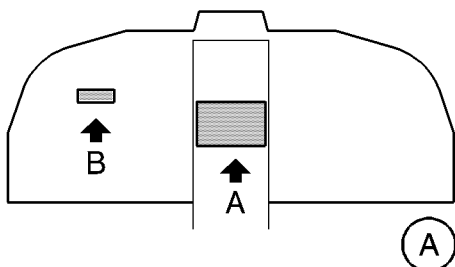

KMD 850

TERR : EGPWS mapping selection

TRFC : TAS function selection

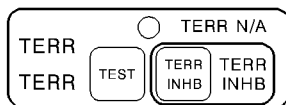

MD41 - 1208

TEST : EGPWS function test switch

TERR INHB : EGPWS warning inhibition switch

I4344500AAACMA8100

TERR (red) : Warnings

TERR (amber) : Cautions

TERR INHB (white) : Inhibited EGPWS warnings

TERR N/A (amber) : EGPWS system not operational

Figure 9.42.6 - KMH 880 system displayed on KMD 850 MFD

"HONEYWELL" **KMH 880** EGPWS/TAS SYSTEM

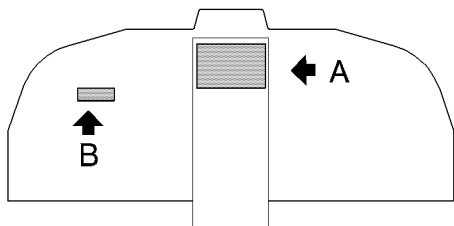

(A)

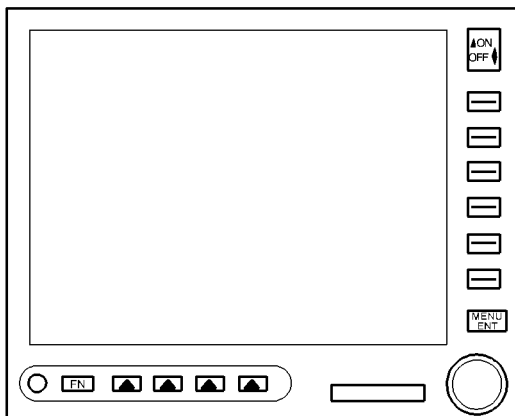

GMX 200

(B)

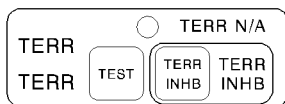

MD41 - 1208

TEST : EGPWS function test switch

TERR INHB : EGPWS warning inhibition switch

TERR (red) : Warnings

TERR (amber) : Cautions

TERR INHB (white) : Inhibited EGPWS warnings

TERR N/A (amber) : EGPWS system not operational

Figure 9.42.6A - KMH 880 system displayed on "GARMIN" GMX 200 MFD

14346200AAADMA8100

SUPPLEMENT
PROVISION FOR TBM 700C2

TABLE OF CONTENTS

	Page
1 - GENERAL	9.43.3
2 - LIMITATIONS	9.43.3
3 - EMERGENCY PROCEDURES	9.43.4
4 - NORMAL PROCEDURES	9.43.4
5 - PERFORMANCE	9.43.4
6 - WEIGHT AND BALANCE	9.43.5
7 - DESCRIPTION	9.43.6
8 - HANDLING, SERVICING AND MAINTENANCE	9.43.7

INTENTIONALLY LEFT BLANK

SECTION 1**GENERAL**

This supplement is intended to inform the pilot about the equipment limitations, description and operations necessary to the operation when the TBM 700C1 airplane is equipped with the option "PROVISION FOR TBM 700C2".

The option consists of :

- new seats with integral belt and shoulder harnesses,
- reinforced main wheels and tires.

SECTION 2**LIMITATIONS**

The limitations hereafter supplement those of the standard airplane described in Section 2 "Limitations" of the basic Pilot's Operating Handbook, when the TBM 700C1 airplane is equipped with the option "PROVISION FOR TBM 700C2".

2.1 - PLACARDS

On main gear leg

**MAIN LANDING GEAR
TIRE PRESSURE : 8,96 bar
130 psi**

On pressurized baggage compartment partition wall

45 Kg - (100 lbs) MAXIMUM

**IT IS THE PILOT'S RESPONSIBILITY TO
CHECK THAT ALL THE BAGGAGES ARE
PROPERLY SECURED**

**FOR LOADING INSTRUCTIONS
SEE "WEIGHT AND BALANCE DATA"
IN PILOT'S OPERATING HANDBOOK**

14113500AAAAM/A8000

SECTION 3

EMERGENCY PROCEDURES

The installation of the option "PROVISION FOR TBM 700C2" does not change the basic emergency procedures of the airplane described in Section 3 "Emergency procedures" of the TBM 700C1 Pilot's Operating Handbook.

SECTION 4

NORMAL PROCEDURES

The installation of the option "PROVISION FOR TBM 700C2" does not change the basic normal procedures of the airplane described in Section 4 "Normal procedures" of the TBM 700C1 Pilot's Operating Handbook.

SECTION 5

PERFORMANCE

The installation of the option "PROVISION FOR TBM 700C2" does not change the basic performance of the airplane described in Section 5 "Performance" of the TBM 700C1 Pilot's Operating Handbook.

SECTION 7

DESCRIPTION

SEATS, BELTS AND HARNESSSES

Cockpit seats

L.H. and R.H. front seats are mounted on rails attached to the structure. Longitudinal position, height and back-rest tilting of each seat can be adjusted and the arm-rest is hinged.

Pull up the handle located forward for longitudinal setting.

The seat height is adjusted by pulling up side forward handle while relieving the seat from the body weight.

The seat back angle is adjusted by pulling up side rearward handle.

Passengers' seats

The accommodation consists of :

- two individual seats, installed back to the flight direction, mounted on the same rails as the front seats.

The seat back angle is adjusted by pulling up side handle.

- two rear seats arranged as a bench, mounted on the same rails as the front seats.

The seat back-rests tilt forward by pulling up a rear handle and each seat may tilt forwards by pulling up a rear handle to ease baggage loading in baggage compartment.

For longitudinal setting pull up the handle located forward.

Belts and harnesses

Each cockpit seat is equipped with a four-point restraint system consisting of an adjustable lap belt and a dual-strap inertia reel-type shoulder harness.

Each passenger seat is equipped with a three-point restraint system consisting of an adjustable lap belt and an inertia reel-type shoulder harness.

SECTION 8

HANDLING, SERVICING AND MAINTENANCE

8.1 - SERVICING

LANDING GEAR

Main gear tires :

18 5.5 10 PR – Inflating pressure : 135 psi (9.32 bars)

NOTE :

Tire inflation pressures are given for an airplane on ground at 21 °C.

An ambient temperature change of 3 °C produces approximately 1 % pressure change.

8.2 - UTILIZATION BY COLD WEATHER (- 0°C TO - 25°C) OR VERY COLD WEATHER (- 25°C TO - 40°C)

NOTE :

Check pressure values in a hangar heated at about 15°C with control equipment at room temperature.

	OAT (° C)	- 40°	- 30°	- 20°	- 10°	+ 15°
PRESSURES psi (bars)	Main landing gear tire	144 (9.96)	144 (9.96)	130 (8.96)	130 (8.96)	130 (8.96)

Table 1

INTENTIONALLY LEFT BLANK

SUPPLEMENT

CHIP DETECTION SYSTEM

TABLE OF CONTENTS

	Page
1 - GENERAL	9.44.2
2 - LIMITATIONS	9.44.2
3 - EMERGENCY PROCEDURES	9.44.3
4 - NORMAL PROCEDURES	9.44.4
5 - PERFORMANCE	9.44.4
6 - WEIGHT AND BALANCE	9.44.4
7 - DESCRIPTION	9.44.5

SECTION 1**GENERAL**

This supplement is intended to inform the pilot about the equipment limitations, description and operations necessary to the operation when the TBM airplane is equipped with the option "CHIP DETECTION SYSTEM".

SECTION 2**LIMITATIONS**

The installation and the operation of the CHIP DETECTION SYSTEM do not change the limitations of the airplane described in Section 2 "Limitations" of the basic Pilot's Operating Handbook.

SECTION 3

EMERGENCY PROCEDURES

The emergency procedures hereafter supplement those of the standard airplane described in Section 3 "Emergency procedures" of the basic Pilot's Operating Handbook, when the TBM airplane is equipped with the option "CHIP DETECTION SYSTEM".

OIL CONTAMINATION CHIP

Indication : "**CHIP**" amber warning on

On ground

Before engine start :

1 - Do not start engine.

After engine start or after landing :

1 - Return to parking area.

2 - Shut down engine.

3 - Inspect chip detector(s) and engine, if required.

In flight

1 - Check and monitor engine parameters.

2 - Land as soon as practical.

3 - Shut down engine.

4 - Inspect chip detector(s) and engine, if required.

SECTION 4
PROCEDURES NORMALES

The normal procedures hereafter supplement those of the standard airplane described in Section 4 "Normal procedures" of the basic Pilot's Operating Handbook, when the TBM airplane is equipped with the option "CHIP DETECTION SYSTEM".

When "CHIP" amber warning goes on, it causes the illumination of the "Master Caution" light.

SECTION 5
PERFORMANCE

The installation and the operation of the CHIP DETECTION SYSTEM do not change the basic performance of the airplane described in Section 5 "Performance" of the basic Pilot's Operating Handbook.

SECTION 6
WEIGHT AND BALANCE

Information hereafter supplement those given for the standard aircraft in Section 6 "Weight and balance" of the basic Pilot's Operating Handbook.

A or O	OPTIONAL EQUIPMENT	EQUIPMENT SUPPLIER	WEIGHT per unit lb (kg)	ARM in. (m)
	79 - LUBRICATION			
A	Chip detection system (2 detectors) (MOD70-0169-79A)		Negligible	/
A	Chip detection system (1 detector) (MOD70-0169-79B)		Negligible	/
A	Chip detection system (2 detectors) with G1000 system (MOD70-0169-79C)		Negligible	/

SECTION 7
DESCRIPTION

The chip detection system enables the monitoring of engine oil system.

The system includes one chip detector installed on propeller reduction gear box and, if installed, a second chip detector installed on engine accessory gear box.

In case of chip detection, amber warning light "CHIP" on advisory panel or amber CAS message "CHIP" on G1000 system screen goes on.

INTENTIONALLY LEFT BLANK

SUPPLEMENT**"GARMIN" GMX 200**
MULTI-FUNCTION DISPLAY**TABLE OF CONTENTS**

	Page
1 - GENERAL	9.46.2
2 - LIMITATIONS	9.46.3
3 - EMERGENCY PROCEDURES	9.46.4
4 - NORMAL PROCEDURES	9.46.4
5 - PERFORMANCE	9.46.5
6 - WEIGHT AND BALANCE	9.46.5
7 - DESCRIPTION	9.46.6

SECTION 1**GENERAL**

This supplement is intended to inform the pilot about the equipment limitations, description and operations necessary to the operation when the TBM airplane is equipped with the option “GARMIN” GMX 200 MULTI-FUNCTION DISPLAY”.

The generalities hereafter supplement those of the standard airplane described in Section 1 “General” of the basic Pilot’s Operating Handbook, when the TBM airplane is equipped with the option “GARMIN” GMX 200 MULTI-FUNCTION DISPLAY”.

The GMX 200 is a multi-function display screen which allows to display topographical type information (rivers, roads, ...), aeronautical type information (VOR, Airport, NDB, ...), as well as information issued from a weather radar, a stormscope, an EGPWS and the active flight plan issued from a GPS.

SECTION 2
LIMITATIONS

The limitations hereafter supplement those of the standard airplane described in Section 2 “Limitations” of the basic Pilot’s Operating Handbook, when the TBM airplane is equipped with the option “GARMIN” GMX 200 MULTI-FUNCTION DISPLAY”.

GMX 200 Multi-function Display Pilot’s Guide, P/N 190-00607-02, Revision A dated June 2006 or any applicable following edition, shall be readily available to the pilot.

The GMX 200 may be used only as an aid to navigation, if :

- navigation is based on other approved instruments,
- the GMX 200 data base is current and compatible with the flight,
- GMX 200 and associated GPS data bases cover the same geographical areas.

CAUTION

**GMX 200 TOPOGRAPHICAL DATA MUST NOT BE USED FOR
TERRAIN AND/OR OBSTACLES AVOIDANCE**

CAUTION

**THE GMX 200 CHART VIEW FEATURE DOES NOT CURRENTLY
REPRESENT A SOLE REPLACEMENT FOR THE PAPER CHART
WITHIN THE COCKPIT. THE PRESENTATION OF THE CHART DATA IS
INTENDED FOR SUPPLEMENTAL USE AND TO PROVIDE
ADDITIONAL SITUATIONAL AWARENESS. THE PILOT MUST STILL
HAVE ACCESS TO THE PRINTED CHART AS REQUIRED BY
REGULATIONS**

SECTION 3

EMERGENCY PROCEDURES

Installation and operation of the “GARMIN” GMX 200 Multi-function Display do not change the emergency procedures described in Section 3 “Emergency procedures” of the basic Pilot’s Operating Handbook.

SECTION 4

NORMAL PROCEDURES

The normal procedures hereafter supplement those of the standard airplane described in Section 4 “Normal procedures” of the basic Pilot’s Operating Handbook, when the TBM airplane is equipped with the option ““GARMIN” GMX 200 MULTI-FUNCTION DISPLAY”.

GMX 200 normal operating procedures recommended by the manufacturer are outlined in the “GARMIN” GMX 200 Multi-function Display Pilot’s Guide, P/N 190-00607-02, Revision A dated June 2006 or any applicable following edition.

SECTION 5
PERFORMANCE

The installation and the operation of the “GARMIN” GMX 200 Multi-function Display do not change the basic performance of the airplane described in Section 5 “Performance” of the basic Pilot’s Operating Handbook.

SECTION 6
WEIGHT AND BALANCE

Information hereafter supplement the one given for the standard airplane in Section 6 “Weight and balance” of the basic Pilot’s Operating Handbook.

A or O	OPTIONAL EQUIPMENT	EQUIPMENT SUPPLIER	WEIGHT per unit lb (kg)	ARM in. (m)
	34 - NAVIGATION			
A	Multi-function display (MOD70-0210-34A) GMX 200	GARMIN	5.423 (2.46)	153.54 (3.90)
A	Multi-function display with chart view (MOD70-0210-34B) GMX 200	GARMIN	5.423 (2.46)	153.54 (3.90)

SECTION 7
DESCRIPTION

- 1 - Power/Dimming
- 2 - Menu Item Keys
- 3 - Menu Enter Key
- 4 - Rotary knob and push-button
- 5 - Data card
- 6 - Function Item Keys
- 7 - Function key
- 8 - Photosensor
- 9 - Menu Item labels
- 10 - Function Item labels
- 11 - Advisory/Data Flags
- 12 - Traffic and terrain thumbnail
- 13 - To waypoint identifier
- 14 - Bearing to destination (TO) WPT

Key to Figure 9.46.1 - GMX 200 Multi-function display (front view)

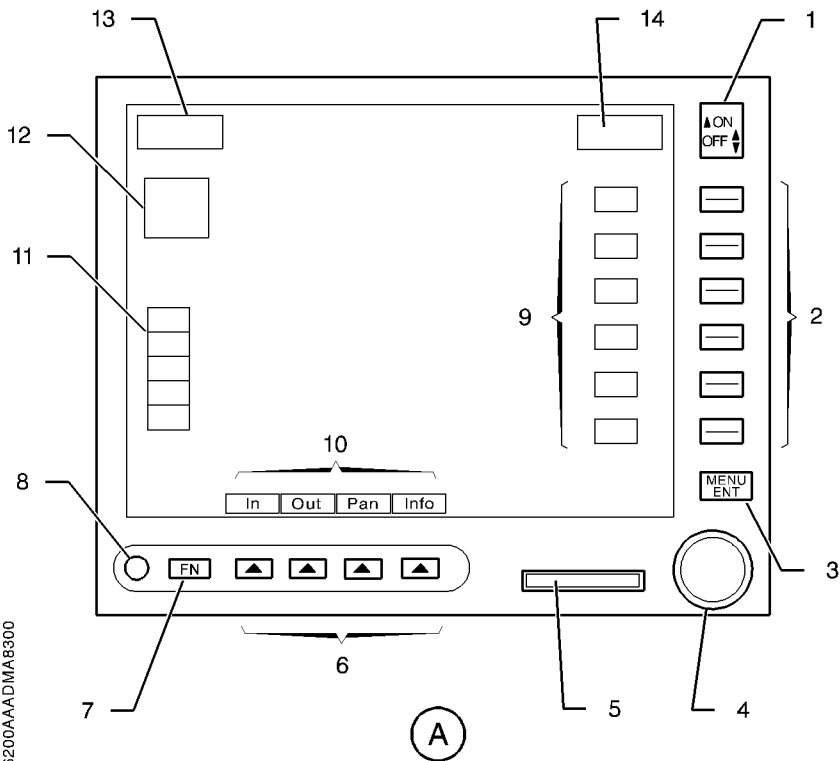
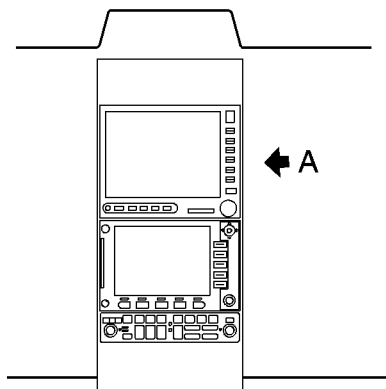

I4346200AAAADMA8300

Figure 9.46.1 - GMX 200 Multi-function display (front view)
(typical arrangement)

INTENTIONALLY LEFT BLANK

SUPPLEMENT

MULTI-MISSION AIRCRAFT

TABLE OF CONTENTS

	Page
1 - GENERAL	9.53.3
2 - LIMITATIONS	9.53.4
3 - EMERGENCY PROCEDURES	9.53.6
4 - NORMAL PROCEDURES	9.53.7
5 - PERFORMANCE	9.53.9
6 - WEIGHT AND BALANCE	9.53.11
7 - DESCRIPTION	9.53.12

INTENTIONALLY LEFT BLANK

SECTION 1
GENERAL

This supplement is intended to inform the pilot about the equipment limitations, procedures and description necessary to the operation when the TBM700 airplane is equipped with "MULTI-MISSION AIRCRAFT" (MMA) option :

The MMA consists in different versions, provided in the table hereafter :

VERSION	EQUIPMENT
A	-THALES AGILE II sphere - Console

The TBM700 MMA may fly :

VERSION	CONFIGURATION
A	A1 - Sphere extended Cabin mission layout A2 - Sphere retracted Cabin standard or mission lay out A3 - Sphere removed Cabin standard or mission lay out

When the airplane is flying in A2 or A3 configuration, the airplane geometry, maximum takeoff weight, weight and balance diagrams, flight envelope and airplane limitations are unchanged.

SECTION 2
LIMITATIONS

2.1 - GENERAL

The limitations hereafter supplement those of the standard airplane described in Section 2 "Limitations" of the basic Pilot's Operating Handbook when the TBM700 airplane is equipped with the "MULTI-MISSION AIRCRAFT" option.

2.2 - AIRSPEED LIMITATIONS

VERSION	SPEED	KIAS	KCAS
A	Maximum operating speed when the sphere is totally or partially extended	160	- 163 for TBM700 A/B/C/N - 164 for TBM850 S/N 269 and from S/N 434

2.3 - OPERATING LIMITS

CAUTION

IT IS PROHIBITED TO OCCUPY THE OPERATOR CONSOLE SEAT DURING TAKEOFF AND LANDING.

FLIGHT INTO KNOWN ICING CONDITIONS WITH TOTALLY OR PARTIALLY EXTENDED SPHERE IS PROHIBITED.

TAKEOFF WITH TOTALLY OR PARTIALLY EXTENDED SPHERE IS PROHIBITED.

LANDING WITH TOTALLY OR PARTIALLY EXTENDED SPHERE IS PROHIBITED EXCEPT IN CASE OF SPHERE RETRACTION PROBLEM.

2.4 - FLIGHT OPERATING LIMITS

VERSION	CONFIGURATION	Maximum altitude
A	Sphere is totally or partially extended	20000 ft (6096 m)

2.5 - MISCELLANEOUS LIMITS

Only cabin standard or mission lay out is allowed to fly.

2.6 - LABELS

<p style="text-align: center;">EXTENDED SPHERE</p> <p style="text-align: center;">IAS \leq 160 KIAS</p> <p style="text-align: center;">Pressure Altitude \leq 20 000 Ft</p> <p style="text-align: center;">Crosswind \leq 15 kt</p> <p style="text-align: center;">Landing prohibited except in case of failure</p>

SECTION 3

EMERGENCY PROCEDURES

The emergency procedures hereafter supplement those of the standard airplane described in Section 3 "Emergency procedures" of the basic Pilot's Operating Handbook, when the TBM700 airplane is equipped with the "MULTI-MISSION AIRCRAFT" option.

SPHERE EXTENSION/RETRACTION FAILURE OR USE OF EMERGENCY STOP

Symptom : Red warning light FIXED

- 1 - Maintain airspeed below **160 KIAS**
- 2 - Shorten the flight
- 3 - Maximum demonstrated crosswind for landing **15 Kts**

ELECTRICAL FAILURE : BOTH GENERATOR FAILURE CONFIRMED ("MAIN GEN" AND "ST-BY")

If sphere is not retracted : RETRACT IT

If sphere is retracted : EXTENSION IS PROHIBITED

SECTION 4 NORMAL PROCEDURES

The normal procedures hereafter supplement those of the standard airplane described in Section 4 "Normal procedures" of the basic Pilot's Operating Handbook, when the TBM700 airplane is equipped with the "MULTI-MISSION AIRCRAFT" option.

BEFORE TAXIING

- 1 - Extension/retraction switch **CHECK UNDER GUARD**
- 2 - Control panel lights **TEST**
(Red and blue lights ON)

EXTEND THE SPHERE

- 1 - Airspeed below **160 KIAS**
- 2 - Extension/retraction switch **ACTUATED and DN**
- 3 - Red warning light **FLASHING**
The red warning light flashes during the whole maneuver. It goes off at the end of the maneuver (Duration : around 1 min 30 sec.)
- 4 - Blue indicator light **ON**

RETRACT THE SPHERE

- 1 - Airspeed below **160 KIAS**
- 2 - Extension/retraction switch **UP**
- 3 - Blue indicator light **OFF**
- 4 - Red warning light **FLASHING**
The red warning light flashes during the whole maneuver. It goes off at the end of the maneuver (Duration : around 1 min 30 sec.)
- 5 - Extension/retraction switch **CHECK UNDER GUARD**

BEFORE LANDING

- 1 - Extension/retraction switch **CHECK UNDER GUARD**

SECTION 5
PERFORMANCE

The performance hereafter supplement those of the standard airplane described in Section 5 "Performance" of the basic Pilot's Operating Handbook, when the TBM700 airplane is equipped with the "MULTI-MISSION AIRCRAFT" option.

5.1 - LONG RANGE CRUISE

When the sphere is extended :

- at iso torque, the airspeed is decreased by 4 KIAS,
- at iso airspeed, the fuel flow is increased by 2 US.Gal/h.

5.2 - WIND COMPONENTS

EXAMPLE : Angle between wind direction and flight path : 50°
 Headwind : 8 kts
 Crosswind : 10 kts
 Wind speed : 13 kts

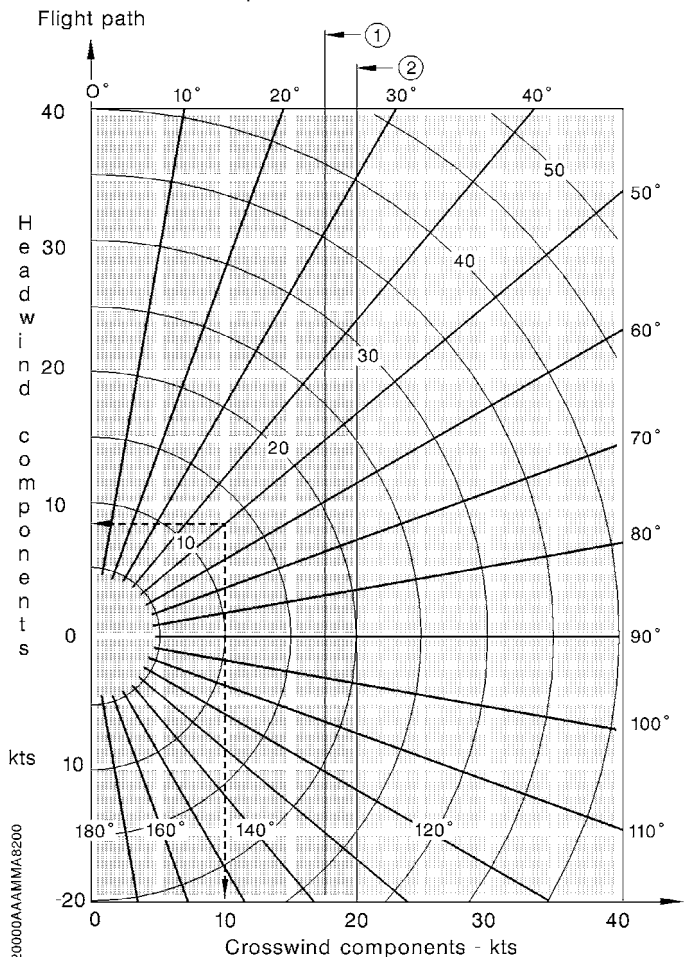

14020000AAAMMA8200

- ① 15 kts - Demonstrated crosswind with sphere extended (totally or partially)
- ② 20 kts - Demonstrated crosswind with sphere retracted

Figure 9.53.1 - WIND COMPONENTS

SECTION 6
WEIGHT AND BALANCE

The weight and balance hereafter supplement those of the standard airplane described in Section 6 "Weight and Balance" of the basic Pilot's Operating Handbook, when the TBM700 airplane is equipped with the "MULTI-MISSION AIRCRAFT" option.

GENERAL

IT IS THE PILOT'S RESPONSIBILITY TO ENSURE THAT THE AIRPLANE IS LOADED PROPERLY AND THE WEIGHT AND BALANCE LIMITS ARE ADHERED TO.

VERSION	EQUIPMENT	WEIGHT lb (kg)	ARM lb (kg)
A	Console	48.5 (22)	236.2 (6.15)
	Sphere	46.3 (21)	354.3 (9.4)

SECTION 7
DESCRIPTION

The description hereafter supplement those of the standard airplane described in Section 7 "Description" of the basic Pilot's Operating Handbook, when the TBM700 airplane is equipped with the "MULTI-MISSION AIRCRAFT" option.

The main components of the Multi-mission aircraft are :

- 1) One extension/retraction control panel (pilot control only),
- 2) One console in order to operate the sphere when extended,
- 3) One external sphere, located between the two lateral keels.

NOTE :

The airplane can be flown with the sphere removed.

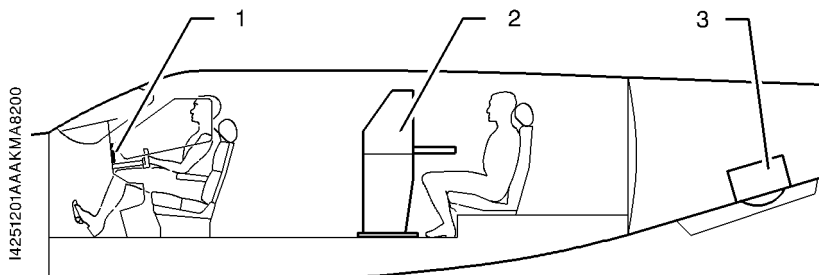

Figure 9.53.2 - MMA COMPONENTS

VERSION	DESCRIPTION
A	1) Control panel 2) Console 3) THALES AGILE II sphere

7.1 - CABIN LAYOUTSAircraft equipped with gaseous oxygen

Either L.H. intermediate seat (Item 1) or L.H. rear seat (Item 2) can be removed if necessary.

Aircraft equipped with chemical oxygen

Either L.H. intermediate seat (Item 1) or L.H. rear seat (Item 2) can be removed if necessary, provided that access to oxygen masks is possible for every passenger aboard during all flight phases.

Cabin standard layout

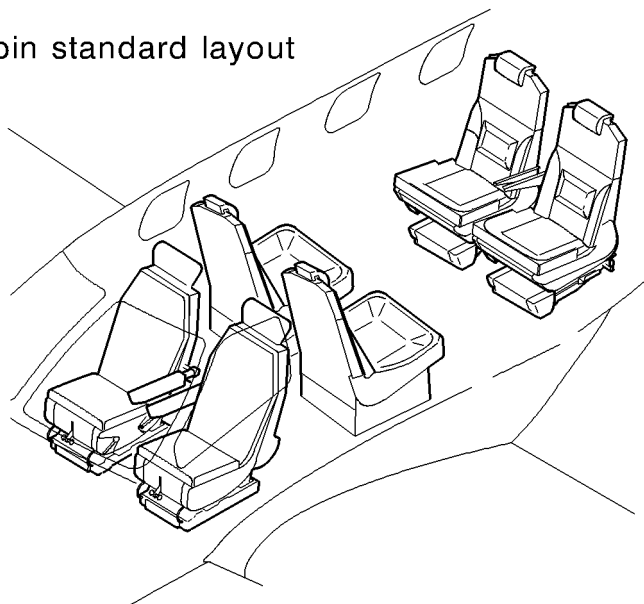

I4251201AAA KMA8100

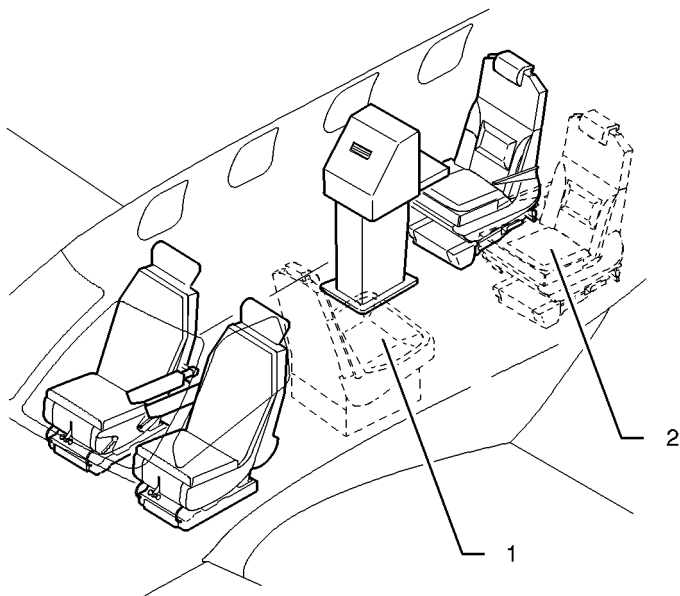

Cabin mission layout

Figure 9.53.3 - CABIN LAYOUTS

7.2 - EXTENSION/RETRACTION CONTROL PANEL

- 1) STOP : Emergency stop - when actuated stops the sphere maneuver.
- 2) Under guard switch : sphere maneuver control.
- 3) Blue indicator light : light is ON if the sphere is extended.
- 4) Red warning light : flashes during sphere maneuver, is ON if a failure is detected.
- 5) Test : when pushed lights on blue/red lights.

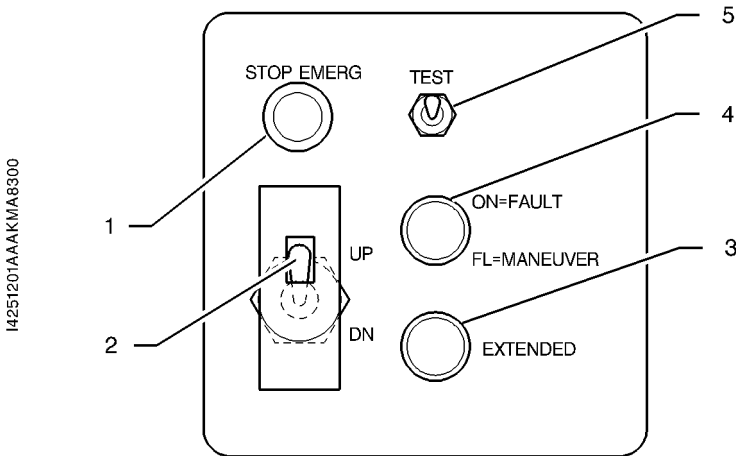

Figure 9.53.4 - CONTROL PANEL

7.3 - BREAKERS

"MMA EXT/RET" breaker protects the EO/IR extension/retraction system.

"MMA CONSOLE" breaker protects the console functioning.

These two breakers are located on the PL 1 breaker panel.

INTENTIONALLY LEFT BLANK

SUPPLEMENT**ADS-B OUT FUNCTION****TABLE OF CONTENTS**

	Page
1 - GENERAL	9.60.2
2 - LIMITATIONS	9.60.2
3 - EMERGENCY PROCEDURES	9.60.2
4 - NORMAL PROCEDURES	9.60.3
5 - PERFORMANCE	9.60.3
6 - WEIGHT AND BALANCE	9.60.3
7 - DESCRIPTION	9.60.4
8 - HANDLING, SERVICING AND MAINTENANCE	9.60.4

SECTION 1

GENERAL

This supplement is intended to inform the pilot about the equipment limitations, description and operations necessary for operation when the airplane is equipped with “ADS-B OUT function”.

The ADS-B OUT function is integrated in the optional modification MOD70-0494-34A : Garmin GTX 330 Diversity Mode S transponder # 1 with the extended squitter functionality.

The installed ADS-B OUT system has been shown to meet the equipment requirements of 14 CFR 91.227.

1.4 - ABBREVIATIONS AND TERMINOLOGY

RADIO-NAVIGATION ABBREVIATIONS

ADS-B : Automatic Dependent Surveillance-Broadcast

SECTION 2

LIMITATIONS

Operation of “ADS-B OUT function” does not change the limitations of the airplane described in Section 2 “Limitations” of the basic Pilot’s Operating Handbook.

SECTION 3

EMERGENCY PROCEDURES

Operation of “ADS-B OUT function” does not change the emergency procedures of the airplane described in Section 3 “Emergency Procedures” of the basic Pilot’s Operating Handbook.

SECTION 4 NORMAL PROCEDURES

Operation of “ADS-B OUT function” does not change the normal procedures of the airplane described in Section 4 “Normal Procedures” of the basic Pilot’s Operating Handbook.

SECTION 5 PERFORMANCE

Operation of “ADS-B OUT function” does not change the performance of the airplane described in Section 5 “Performance” of the basic Pilot’s Operating Handbook.

SECTION 6 WEIGHT AND BALANCE

Information hereafter supplement or replace those of the standard airplane described in Section 6 “Weight and Balance” of the basic Pilot’s Operating Handbook when the airplane is equipped with the “ADS-B OUT function”.

S/ R/ A/ O	ITEM OPT70 or MOD70	REQUIRED (R) OR STANDARD (S) OR OPTIONAL (A or O) EQUIPMENT	WEIGHT per unit lb (kg)	ARM in. (m)
		34 - NAVIGATION		
		34-53 - Transponder		
O	0494-34A	Transponder # 1 Mode S with diversity and extended squitter	GTX330D ES 7.50 (3.400)	153.86 (3.908)

SECTION 7

DESCRIPTION

Information hereafter supplement or replace those of the standard airplane described in Section 7 "Description" of the basic Pilot's Operating Handbook when the airplane is equipped with the "ADS-B OUT function".

The "ADS-B OUT function" enables the airplane to broadcast data, such as position information, to ground stations and to other airplanes equipped with ADS-B IN system.

ADS-B OUT data is only transmitted via transponder # 1. Use of transponder # 2 (if installed) results in a loss of the ADS-B OUT data transmission.

The loss of an interfaced input to the transponder #1 may cause the transponder to stop transmitting ADS-B OUT data. Depending on the nature of the fault or failure, the transponder may no longer be transmitting all of the required data in the ADS-B OUT messages.

If the transponder # 1 detects any internal fault or failure with the ADS-B OUT functionality, the following advisory message "NO ADSB" will be displayed on the transponder screen.

After being informed of ADS-B OUT failure either by the advisory message "NO ADSB" or by Air Traffic Control, it is possible to disable ADS-B OUT function by selecting transponder # 2 (if installed).

SECTION 8

HANDLING, SERVICING AND MAINTENANCE

Operation of "ADS-B OUT function" does not change the handling, servicing and maintenance of the airplane described in Section 8 "Handling, Servicing and Maintenance" of the basic Pilot's Operating Handbook.